

MISSOURI HIGHWAYS and TRANSPORTATION COMMISSION

JEFFERSON CITY, MISSOURI

**SUPPLEMENTAL PLANS TO JULY 2024 MISSOURI STANDARD
PLANS FOR HIGHWAY CONSTRUCTION**

EFFECTIVE January 1, 2025

MISSOURI HIGHWAYS AND TRANSPORTATION COMMISSION
MISSOURI STANDARD PLANS FOR HIGHWAY CONSTRUCTION
TABLE OF CONTENTS

EFFECTIVE: 01/01/2025

STANDARD NO.	DRAWING TITLE	NO. OF SHEETS	EFFECTIVE DATE
203.00E	EXCAVATION AND EMBANKMENT – TYPICAL DETAILS	1	08/01/1998
203.02F	UNDERGRADING – TYPICAL DETAILS	2	01/01/2004
203.10D	TABULATED EARTHWORK AND SECTION DATA	1	02/01/2009
203.20G	SUPERELEVATION, SPIRALS AND WIDENING (UNDIVIDED HIGHWAY)	4	07/01/2017
203.21K	SUPERELEVATION, SPIRALS AND WIDENING (DIVIDED HIGHWAY)	3	07/01/2017
203.22A	SUPERELEVATION, SPIRALS AND WIDENING	2	04/01/2024
203.35A	MAILBOX TURNOUTS	1	08/01/1981
203.40G	TYPICAL DETAILS ON AND OFF RAMP	2	10/01/2007
203.41F	TYPICAL DETAILS ON AND OFF RAMPS (ROADWAY WITH 6:1 FORESLOPE)	2	01/01/1995
203.50N	TYPICAL MEDIAN OPENINGS (DIVIDED HIGHWAYS)	2	04/01/2016
203.61B	DRIVEWAY – TYPE I	1	07/01/2020
203.62E	DRIVEWAY – TYPE II	2	07/01/2020
203.63C	DRIVEWAY – TYPE III	2	07/01/2020
203.64E	DRIVEWAY – TYPE IV	2	07/01/2020
203.65B	DRIVEWAY – TYPE V	1	07/01/2020
204.00D	EMBANKMENT CONTROL – MEASURING DEVICES	1	04/01/1983
204.30	PORE PRESSURE MEASUREMENT DEVICES	1	03/01/1996
401.00C	TYPE A2 AND A3 SHOULDERS, SAFETY EDGE SM	3	07/01/2018
413.20	SCRUB SEAL BROOM CONFIGURATION	1	07/01/2004
502.05S	CONCRETE PAVEMENT AND BASE APPURTENANCES FOR 15 FT. JOINT SPACING	4	04/01/2023
502.10L	DOWEL SUPPORTING UNITS	2	07/01/2023
504.00L	CONCRETE APPROACH PAVEMENT	3	10/01/2022
506.20	BIG BLOCK UNBONDED CONCRETE OVERLAY	1	07/01/2021
602.00D	RIGHT-OF-WAY AND DRAIN MARKERS	2	01/01/2003
604.05D	PIPE CULVERT HEADWALLS – TYPE S	2	08/01/2006
604.10E	PIPE CULVERT HEADWALLS – ENERGY DISSIPATOR FOR 18" CONCRETE PIPE	1	07/01/2001
604.11E	PIPE CULVERT HEADWALLS – ENERGY DISSIPATOR FOR 24" CONCRETE PIPE	1	07/01/2001
604.12E	PIPE CULVERT HEADWALLS – ENERGY DISSIPATOR FOR 30" CONCRETE PIPE	1	07/01/2001
604.13E	PIPE CULVERT HEADWALLS – ENERGY DISSIPATOR FOR 36" CONCRETE PIPE	1	07/01/2001
604.14E	PIPE CULVERT HEADWALLS – ENERGY DISSIPATOR FOR 42" CONCRETE PIPE	1	07/01/2001
604.15E	PIPE CULVERT HEADWALLS - ENERGY DISSIPATOR FOR 48" CONCRETE PIPE	1	07/01/2001
604.29C	DROP INLET - TYPE X	2	04/01/2018
604.30G	CONCRETE MANHOLES	2	02/01/2009
604.40G	PIPE COLLARS	2	07/01/2021
604.70	SLOTTED DRAIN	2	03/01/1994
605.10I	PAVEMENT UNDERDRAINAGE	4	06/01/2013
606.00AY	GUARDRAIL	7	01/01/2020
606.01F	MEDIAN PIER PROTECTION	9	04/01/2021
606.22U	BRIDGE ANCHOR SECTION - SAFETY BARRIER CURB ON BRIDGE	6	07/01/2016
606.23J	BRIDGE ANCHOR SECTION - THRIE BEAM RAIL ON BRIDGE	5	07/01/2016
606.30L	GUARDRAIL - TERMINAL ANCHOR ENDS	7	04/01/2021
606.31B	CRASHWORTHY END TERMINALS - TYPE A - GRADING LIMITS	1	10/01/2019
606.40D	ONE-STRAND ACCESS RESTRAINT CABLE	2	07/01/2004
606.41N	REPAIR ONLY: LOW-TENSION GUARD CABLE	7	07/01/2024
606.42	HIGH-TENSION GUARD CABLE	2	07/01/2024

STANDARD NO.	DRAWING TITLE	NO. OF SHEETS	EFFECTIVE DATE
606.50F	MIDWEST GUARDRAIL SYSTEM (MGS)	9	07/01/2024
606.51	MIDWEST GUARDRAIL SYSTEM (MGS) - MEDIAN PIER PROTECTION	2	04/01/2021
606.60B	MIDWEST GUARDRAIL SYSTEM (MGS) - VERTICAL BARRIER TRANSITIONS	6	07/01/2021
606.61	MIDWEST GUARDRAIL SYSTEM (MGS) - 38-INCH TWO-TUBE RAIL TRANSITIONS	3	04/01/2024
606.70B	MIDWEST GUARDRAIL SYSTEM (MGS) - THRIE BEAM RAIL ON BRIDGE	5	04/01/2018
606.80C	MIDWEST GUARDRAIL SYSTEM (MGS) - TERMINAL ANCHOR ENDS	7	07/01/2021
606.81B	MASH - CRASHWORTHY END TERMINALS - TYPE A - GRADING LIMITS	1	10/01/2019
607.10W	CHAIN-LINK FENCE	1	04/01/2024
607.11J	CHAIN-LINK FENCE FOR RETAINING WALLS	1	04/01/2024
607.20H	WOVEN WIRE FENCE	2	04/01/2024
608.00L	PAVED APPROACHES	2	04/01/2024
608.10P	CONCRETE SIDEWALK	1	04/01/2015
608.20E	CONCRETE STAIRS	2	04/01/2015
608.30A	CONCRETE MEDIAN STRIP	1	10/01/2020
608.40A	HANDRAILING	4	01/01/2021
608.50A	CURB RAMPS	4	01/01/2023
609.00R	CONCRETE CURB, CURB AND GUTTER, AND GUTTER *	2	01/01/2025
609.15D	PAVED DITCHES	1	07/01/2016
609.40U	DRAIN BASIN, SHOULDER PAVING AND FILL SLOPES AT BRIDGE ENDS	3	10/01/2023
609.60D	ROCK DITCH LINER	1	07/01/2023
609.70C	ROCK LINING FOR CULVERT OUTLET	1	10/01/1981
611.60R	CONCRETE SLOPE PROTECTION	1	07/01/2015
612.20F	SAND FILLED IMPACT ATTENUATORS	1	04/01/2024
613.00T	PAVEMENT REPAIR	4	01/01/2020
614.10U	GRATES AND BEARING PLATES	1	10/01/2021
614.11D	CURVED VANE GRATE AND FRAME	1	01/01/2021
614.30E	MANHOLE AND FRAME COVERS	2	07/01/1996
616.10BE	TEMPORARY TRAFFIC CONTROL DEVICES	9	07/01/2024
616.20D	TEMPORARY TRAFFIC CONTROL PLANS - TWO-LANE ROADWAYS *	5	10/01/2024
617.10M	PERMANENT CONCRETE TRAFFIC BARRIER	11	10/01/2020
617.20F	TEMPORARY CONCRETE TRAFFIC BARRIER	8	01/01/2021
619.10J	PAVEMENT EDGE TREATMENT	1	10/01/2017
620.00N	PAVEMENT MARKING	6	10/01/2022
620.10G	TEMPORARY PAVEMENT MARKING	5	07/01/2017
625.00	HOLE PATTERN FOR PAVEMENT SLAB STABILIZATION	1	10/01/1998
626.00H	RUMBLE STRIPS	2	07/01/2022

* REVISED OR ADDED SINCE JULY 2024

MISSOURI HIGHWAYS AND TRANSPORTATION COMMISSION
MISSOURI STANDARD PLANS FOR HIGHWAY CONSTRUCTION
TABLE OF CONTENTS

EFFECTIVE: 01/01/2025

STANDARD NO.	DRAWING TITLE	NO. OF SHEETS	EFFECTIVE DATE
703.10J	CONCRETE SINGLE BOX CULVERT – STRAIGHT WINGS (SQUARED)	3	01/01/2021
703.11J	CONCRETE SINGLE BOX CULVERT – FLARED WINGS (SQUARED)	3	01/01/2021
703.12J	CONCRETE SINGLE BOX CULVERT – STRAIGHT WINGS (LEFT ADVANCE)	3	01/01/2021
703.13J	CONCRETE SINGLE BOX CULVERT – FLARED WINGS (LEFT ADVANCE)	3	01/01/2021
703.14J	CONCRETE SINGLE BOX CULVERT – STRAIGHT WINGS (RIGHT ADVANCE)	3	01/01/2021
703.15E	CONCRETE SINGLE BOX CULVERT – FLARED WINGS (RIGHT ADVANCE)	3	01/01/2021
703.16	CONCRETE SINGLE BOX CULVERT – CUT SECTIONS	1	01/01/2021
703.17A	CONCRETE SINGLE BOX CULVERT – MEMBER SIZES AND REINFORCEMENT	14	07/01/2023
703.37C	CONCRETE BOX CULVERT – EXTERIOR WING REINFORCEMENT	2	04/01/2011
703.38A	CONCRETE BOX CULVERT – CUTTING DETAILS	2	10/01/2009
703.40H	CONCRETE DOUBLE BOX CULVERT – STRAIGHT WINGS (SQUARED)	3	01/01/2021
703.41H	CONCRETE DOUBLE BOX CULVERT – FLARED WINGS (SQUARED)	3	01/01/2021
703.42H	CONCRETE DOUBLE BOX CULVERT – STRAIGHT WINGS (LEFT ADVANCE)	3	01/01/2021
703.43H	CONCRETE DOUBLE BOX CULVERT – FLARED WINGS (LEFT ADVANCE)	3	01/01/2021
703.44H	CONCRETE DOUBLE BOX CULVERT – STRAIGHT WINGS (RIGHT ADVANCE)	3	01/01/2021
703.45C	CONCRETE DOUBLE BOX CULVERT – FLARED WINGS (RIGHT ADVANCE)	3	01/01/2021
703.46	CONCRETE DOUBLE BOX CULVERT – CUT SECTION	1	01/01/2021
703.47A	CONCRETE DOUBLE BOX CULVERT – MEMBER SIZES AND REINFORCEMENT	27	07/01/2023
703.60E	CONCRETE BOX STRUCTURE – PIPE INLET	1	07/01/2001
703.80H	CONCRETE TRIPLE BOX CULVERT – STRAIGHT WINGS (SQUARED)	3	01/01/2021
703.81H	CONCRETE TRIPLE BOX CULVERT – FLARED WINGS (SQUARED)	3	01/01/2021
703.82H	CONCRETE TRIPLE BOX CULVERT – STRAIGHT WINGS (LEFT ADVANCE)	3	01/01/2021
703.83H	CONCRETE TRIPLE BOX CULVERT – FLARED WINGS (LEFT ADVANCE)	3	01/01/2021
703.84H	CONCRETE TRIPLE BOX CULVERT – STRAIGHT WINGS (RIGHT ADVANCE)	3	01/01/2021
703.85C	CONCRETE TRIPLE BOX CULVERT – FLARED WINGS (RIGHT ADVANCE)	3	01/01/2021
703.86	CONCRETE TRIPLE BOX CULVERT – CUT SECTIONS	1	01/01/2021
703.87A	CONCRETE TRIPLE BOX CULVERT – MEMBER SIZES AND REINFORCEMENT	27	07/01/2023
706.35H	BAR SUPPORTS FOR CONCRETE REINFORCEMENT	1	07/01/2004
712.40L	STEEL DAMS AT EXPANSION JOINTS	1	10/01/2019
725.00C	CORRUGATED METAL PIPE INSTALLATION METHODS	5	04/01/2011
725.31C	METAL CURTAIN WALL AND METAL INLETS	1	07/01/2004
726.30J	RIGID CULVERT INSTALLATION METHODS	2	04/01/2015
730.00E	THERMOPLASTIC PIPE INSTALLATION METHODS	1	04/01/2015
731.00U	PRECAST MANHOLES	2	07/01/2016
731.10T	PRECAST DROP INLET	8	01/01/2025
732.00S	FLARED END SECTION	3	07/01/2021
732.05D	BEVELED PIPE END TREATMENT	2	01/01/2021
732.10H	SAFETY SLOPE END SECTION	3	01/01/2021
733.00	PRECAST CONCRETE BOX CULVERT TIES	1	07/01/2021
805.00A	SEEDING	1	04/01/2024
806.10K	TEMPORARY EROSION CONTROL MEASURES	6	01/01/2023
808.00	TYPICAL PLANTING ILLUSTRATIONS	3	07/01/2004

STANDARD NO.	DRAWING TITLE	NO. OF SHEETS	EFFECTIVE DATE
901.00AB	HIGHWAY LIGHTING – POLES, FOUNDATION & APPURTENANCES FOR 30' M.H.	4	01/01/2021
901.01AJ	HIGHWAY LIGHTING – POLES, FOUNDATION & APPURTENANCES FOR 45' M.H.	6	01/01/2021
901.02B	HIGHWAY LIGHTING – CABLE, CONDUIT AND TRENCHING	1	04/01/2002
901.30F	HIGHWAY LIGHTING – BASE MOUNTED CONTROL STATION	2	04/01/2005
901.80D	HIGHWAY LIGHTING – POWER SUPPLY ASSEMBLY – SECONDARY SERVICE	2	04/01/2002
901.85B	HIGHWAY LIGHTING SYMBOLS	1	04/01/2018
902.00Q	TRAFFIC SIGNALS	2	07/01/2023
902.05	TRAFFIC SIGNALS – ACCESSIBLE PEDESTRIAN SIGNALS	2	04/01/2021
902.10Q	TRAFFIC SIGNALS – CONTROLLERS CONDUIT LOCATION	1	04/01/2005
902.15K	TRAFFIC SIGNALS – POWER SUPPLY ASSEMBLY	3	07/01/2004
902.20G	TRAFFIC SIGNALS – CONCRETE PULL BOXES	3	04/01/2019
902.21C	TRAFFIC SIGNALS – TELEPHONE INTERCONNECT	1	03/01/1996
902.30P	TRAFFIC SIGNALS – POST BASES	2	04/01/2024
902.40R	TRAFFIC SIGNALS – TUBULAR STEEL POSTS	3	04/01/2018
902.50M	TRAFFIC SIGNALS – INDUCTION LOOP DETECTORS	2	04/01/2020
902.70Q	TRAFFIC SIGNALS – RIGID SPAN WIRE DETAILS	3	01/01/2022
902.80L	TRAFFIC SIGNALS – TRAFFIC SIGNAL SYMBOLS	1	04/01/2020
903.01J	STANDARD ARROW DETAILS	2	10/01/2016
903.02AQ	HIGHWAY SIGNING	8	01/01/2025
903.03BS	POST INSTALLATION AND SIGN MOUNTING DETAILS	16	01/01/2025
903.04F	HIGHWAY SIGNING – WEIGH STATION	1	02/01/2012
903.05L	HIGHWAY SIGNING – TUBULAR SUPPORT STEEL – TYPE S, ONE TUBE	2	10/01/2022
903.06L	HIGHWAY SIGNING – TUBULAR SUPPORT STEEL – TYPE S, TWO TUBE	2	10/01/2022
903.07L	HIGHWAY SIGNING – TUBULAR SUPPORT STEEL – TYPE C	2	10/01/2022
903.08K	HIGHWAY SIGNING – TUBULAR SUPPORT STEEL – TYPE B	2	10/01/2022
903.10BE	OVERHEAD SIGN TRUSSES – ALUMINUM	6	10/01/2023
903.12AA	OVERHEAD SIGN TRUSSES – BUTTERFLY AND CANTILEVER STRUCTURAL STEEL	7	01/01/2021
903.60AC	OVERHEAD SIGN TRUSSES – STRUCTURAL STEEL	5	01/01/2021

* REVISED OR ADDED SINCE JULY 2024

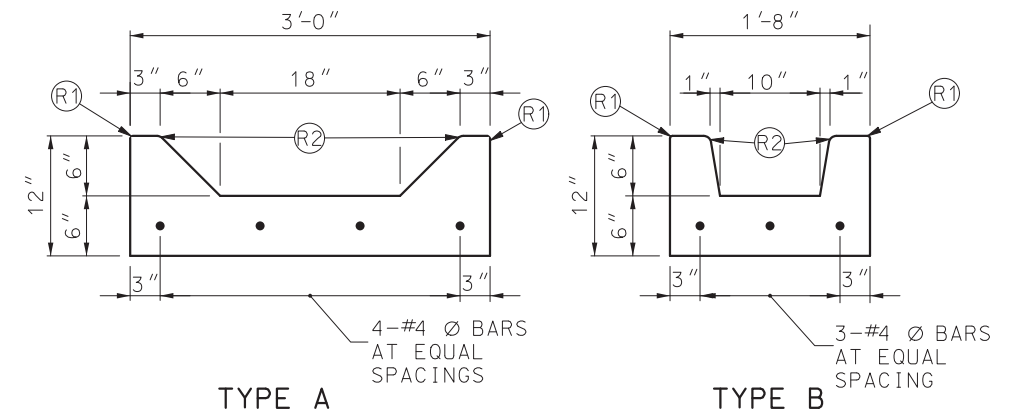
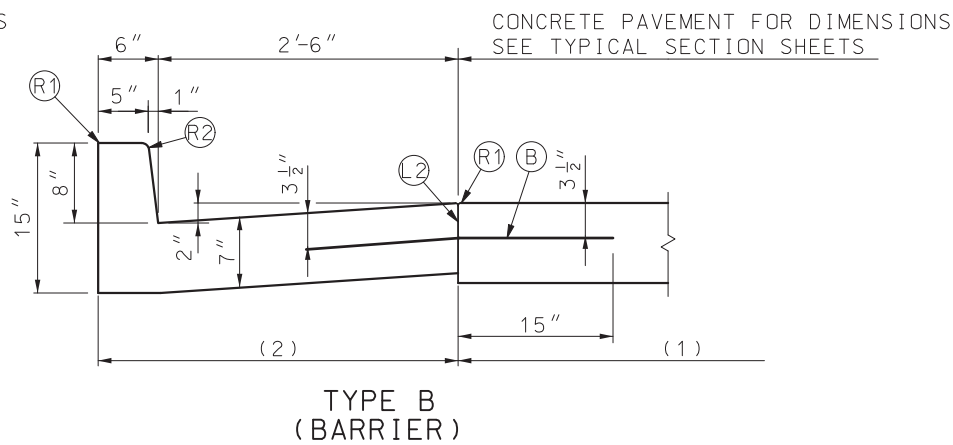
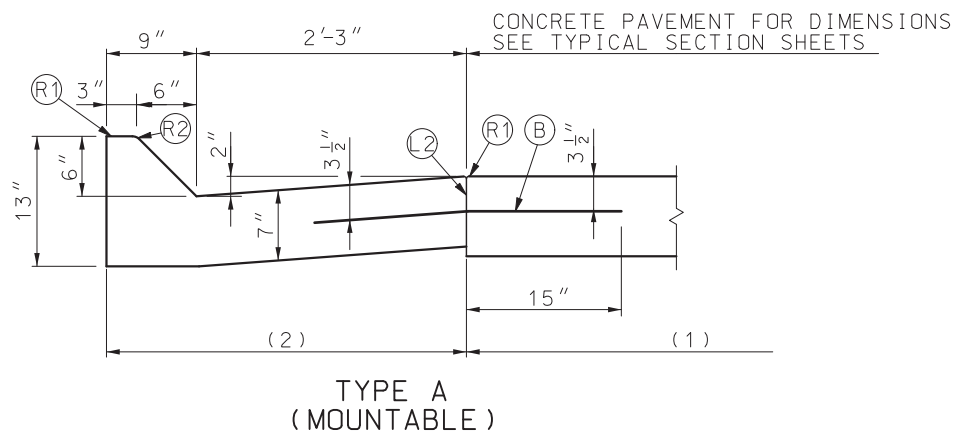

CURB & GUTTER

GUTTERS

SEE STANDARD PLAN 607.11 FOR MODIFIED TYPE A AND B GUTTERS

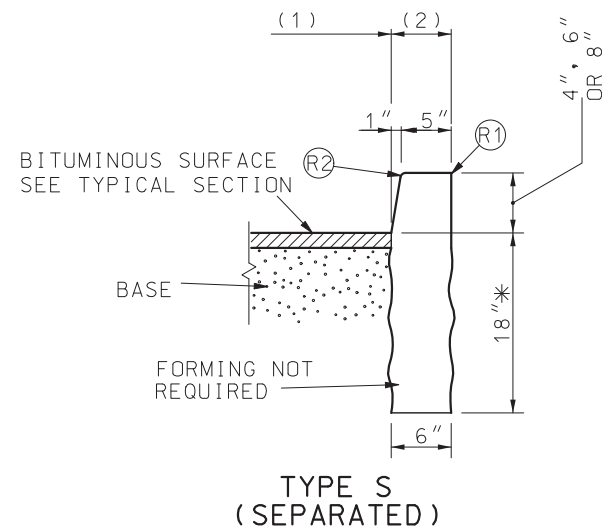
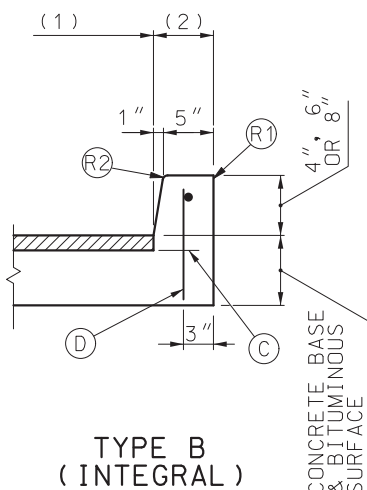
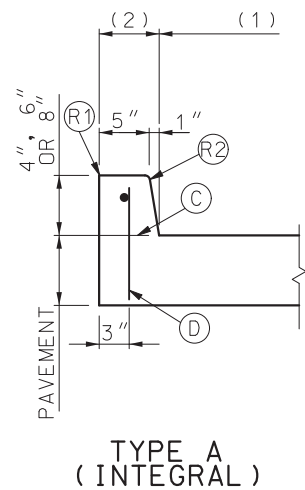

BARRIER CURBS

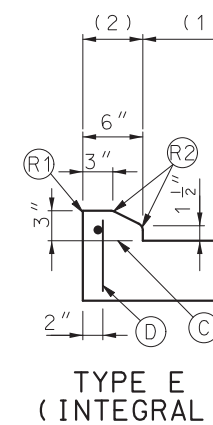
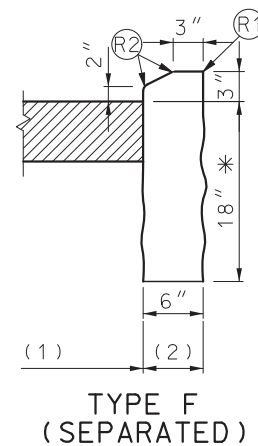
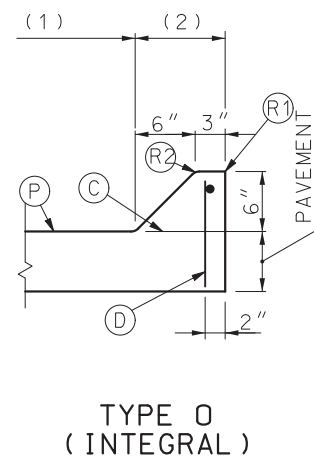
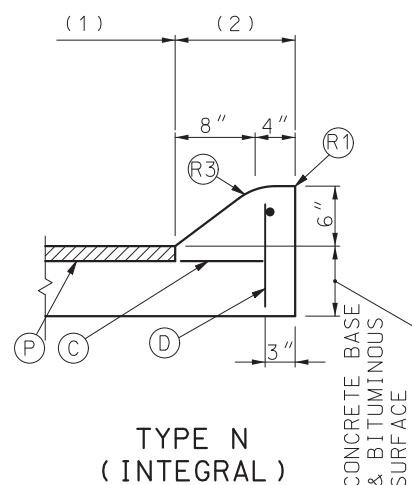
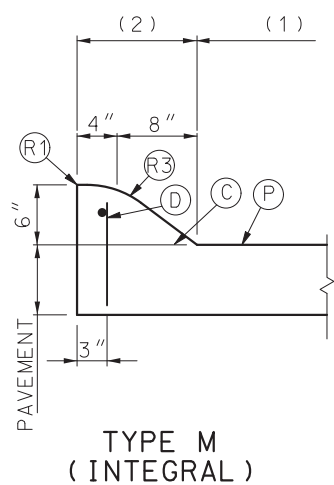

MOUNTABLE CURBS

BEGINNING AND ENDING OF INTRODUCED LOW PROFILE CURB SHALL UTILIZE CURB HEIGHT RUNOUT FORM 0 INCHES TO 3 INCHES IN 5 FEET. PAYMENT LENGTH SHALL INCLUDE TAPERS.
* DEPTH MAY BE REDUCED IF KEYED 6" IN ROCK.

LOW PROFILE CURB

LEGEND

- (B) TIE BARS - 30" X #5 Ø AT 30" CTRS.
- (C) PERMISSIBLE CONSTRUCTION JOINT. IF CONSTRUCTED IN THIS MANNER LONGITUDINAL AND TIE BARS MUST BE USED.
- (D) #3 OR #4 Ø EPOXY COATED LONGITUDINAL AND TIE BARS. LONGITUDINAL BAR GAPPED 4" AT JOINTS AND ANY SPLICES LAPPED 8". TIE BARS AT 24" CENTERS AND LENGTH EQUALS THICKNESS OF PAVEMENT PLUS HEIGHT OF CURB MINUS 3". MINIMUM 1" COVER OVER ALL BARS.
- (L2) LONGITUDINAL JOINT WITH TIE BARS.
- (P) TOP OF PAVEMENT OR CONCRETE BASE.
- (R1) ROUND TO 1/4" RADIUS (EXCEPT FOR SAWED JOINTS).
- (R2) ROUND TO 3/4" RADIUS.
- (R3) CONSTRUCT TO 9" RADIUS.
- (1) PAY LIMIT FOR PAVEMENT
- (2) PAY LIMIT FOR CURB, OR CURB & GUTTER.

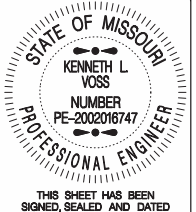
 <p>MISSOURI HIGHWAYS AND TRANSPORTATION COMMISSION</p> <p>105 WEST CAPITOL JEFFERSON CITY, MO 65102 1-888-ASK-MODOT (1-888-275-6636)</p>	
 <p>STATE OF MISSOURI KENNETH L. VOSS NUMBER PE-2002016747 PROFESSIONAL ENGINEER</p> <p>THIS SHEET HAS BEEN SIGNED, SEALED AND DATED ELECTRONICALLY.</p>	<p>CONCRETE CURB, CURB AND GUTTER, AND GUTTER</p>
<p>DATE EFFECTIVE: 1/1/2025 DATE PREPARED: 10/4/2024</p>	<p>609.00R</p>
<p>SHEET NO. 2 OF 2</p>	



W020-1
2



W020-4
7



W020-7a
8



G020-4
53

SIGN 53, "PILOT CAR FOLLOW ME" SHALL BE THE CONTRACTOR'S RESPONSIBILITY WHEN IN USE DURING OPERATION.

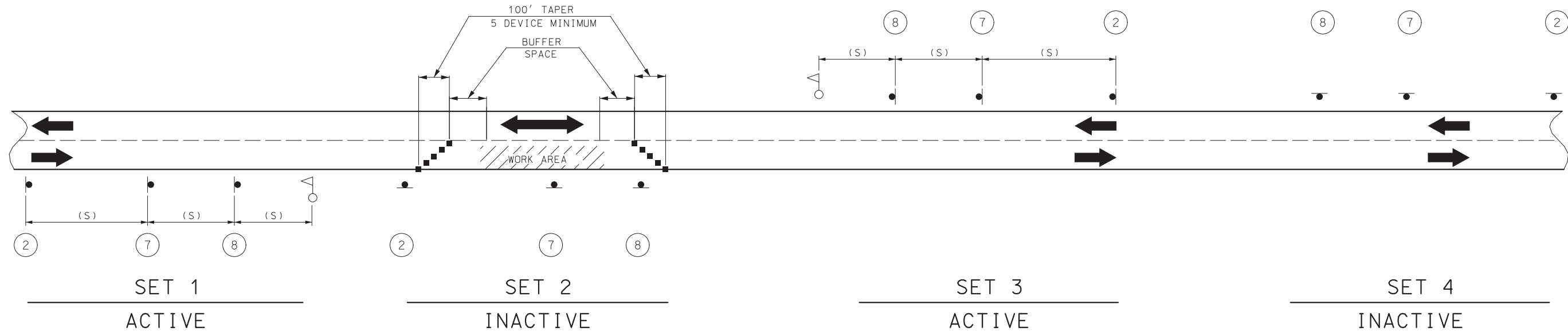

NOTES:

THIS PLAN IS FOR DAYLIGHT FLAGGING OPERATIONS ONLY. WHEN NIGHT WORK IS REQUIRED, OR OTHERWISE ALLOWED BY THE ENGINEER, WORK ZONE LIGHTING SHALL BE PROVIDED IN ACCORDANCE WITH SEC 616.5.2.

CHANNELIZING DEVICES LOCATED DOWNSTREAM OF THE ONE-LANE, TWO-WAY TAPER ARE OPTIONAL. THESE DEVICES SHOULD BE ELIMINATED WHEN THEIR USE WILL REDUCE THE USABLE LANE WIDTH, INCLUDING ANY ACCEPTABLE SHOULDERS, TO LESS THAN 10' OR WILL SIGNIFICANTLY AFFECT THE RESURFACING OPERATION.

SIGN SETS 1 AND 3 ARE ACTIVE AND (I.E., SIGNS FACE ONCOMING TRAFFIC) SIGN SETS 2 AND 4 ARE INACTIVE (I.E., SIGNS DO NOT FACE EITHER DIRECTION OF TRAFFIC) WHEN THE RESURFACING OPERATION IS LOCATED BETWEEN SIGN SETS 1 AND 3.

WHEN SIGN SETS 2 AND 4 ARE ACTIVE, SIGN SETS 1 AND 3 BECOME INACTIVE AND ARE ADVANCED TO BECOME SETS 2 AND 4 WITH SIGN LEGENDS TURNED AWAY FROM BOTH DIRECTIONS OF TRAFFIC. WHEN THE RESURFACING OPERATION ADVANCES TO BETWEEN SIGN SETS 2 AND 4, SIGN SETS 2 AND 4 BECOME ACTIVE (I.E., NEW SIGN SETS 1 AND 3) AND SIGN SETS 1 AND 3 ADVANCED IN THE DIRECTION OF THE OPERATION (I.E., NEW SIGN SETS 2 AND 4).

■ - CHANNELIZERS

○ - FLAGGER

SPEED	SIGN SPACING (FT) (1)	BUFFER SPACE LENGTH (FT)
0-35	200	250
40-45	350	360
50-55	500	495
60-70	1000	730

(1) SPACING BETWEEN SIGNS, BETWEEN LAST SIGN AND FLAGGER, BEGINNING OF TAPER OR SIGNED CONDITION.

SPACING MAY BE ADJUSTED AS NECESSARY TO MEET FIELD CONDITIONS.

NOT TO SCALE

MISSOURI HIGHWAYS AND TRANSPORTATION COMMISSION
 105 WEST CAPITOL JEFFERSON CITY, MO 65102
 1-888-ASK-MODOT (1-888-275-6636)

TEMPORARY TRAFFIC CONTROL PLANS
 PAVEMENT TREATMENTS FOR TWO-LANE ROADWAYS

STATE OF MISSOURI
 KENNETH L. VOSS
 NUMBER PE-2002016747
 PROFESSIONAL ENGINEER

THIS SHEET HAS BEEN SIGNED, SEALED AND DATED ELECTRONICALLY.

DATE EFFECTIVE: 10/1/2024
 DATE PREPARED: 7/11/2024

616.20D

SHEET NO.
 2 OF 5

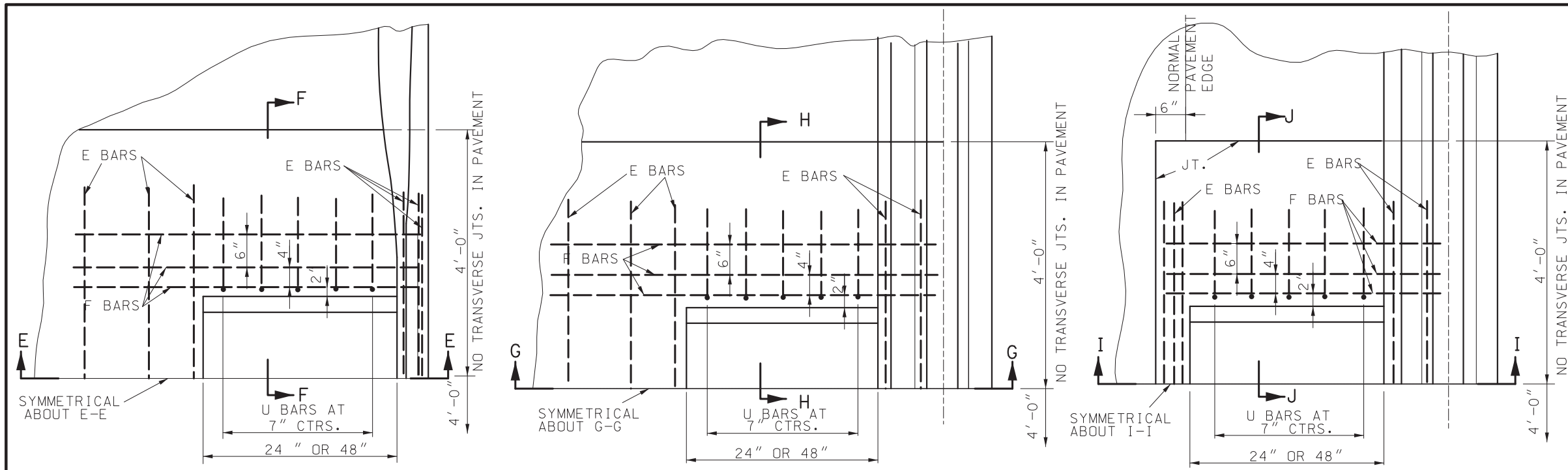

HALF-PLAN

HALF-PLAN

HALF-PLAN

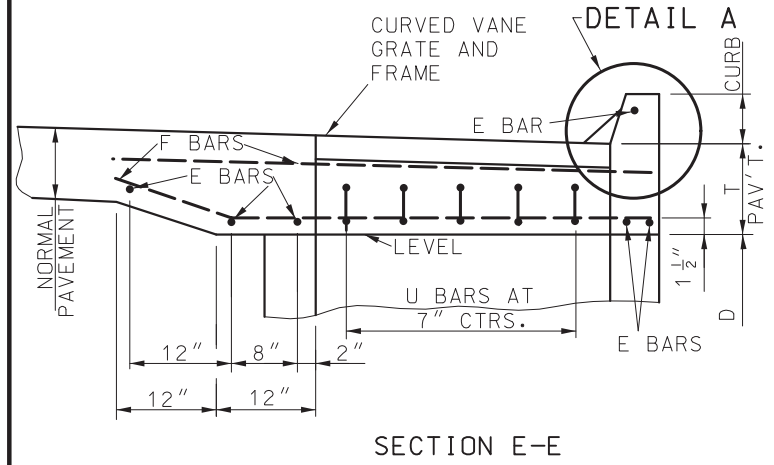

SECTION E-E

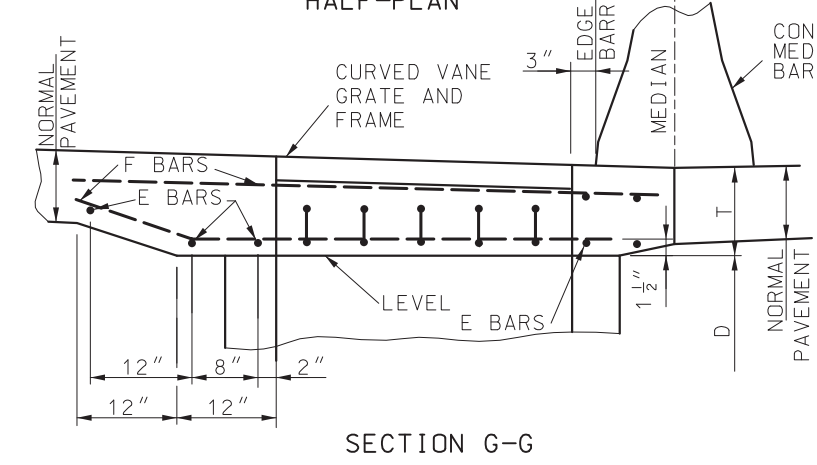

SECTION G-G

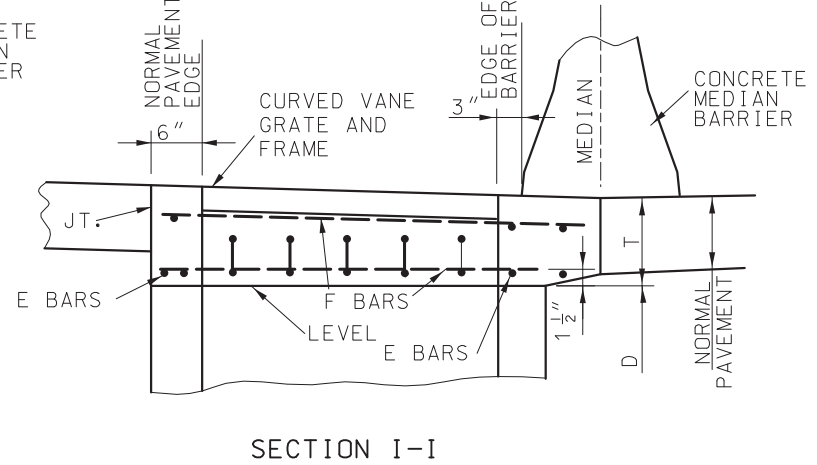

SECTION I-I

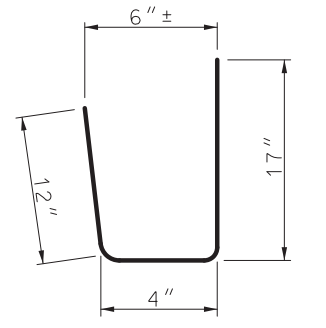

U-BARS BENDING DIAGRAM

BARS E, F, & U.....#4

PAVEMENT BAR BILL					
TYPE	WIDTH	LENGTH	MARK	NO.	LENGTH
A	4'	2'	E	6	6'-0"
			F	6	6'-6"
			U	14	2'-9"
B	2'	2'	E	6	6'-0"
			F	6	4'-6"
			U	8	2'-9"
C	4'	2'	E	7	6'-0"
			F	6	7'-0"
			U	14	2'-9"
D	2'	2'	E	7	6'-0"
			F	6	5'-0"
			U	8	2'-9"

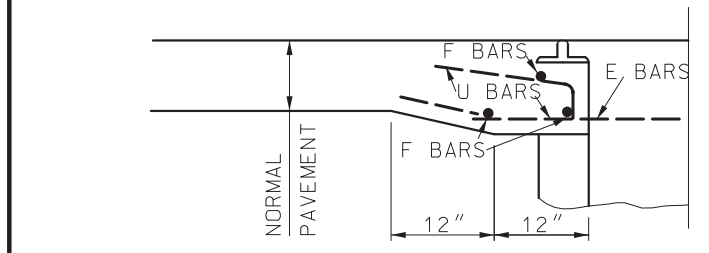

HALF SECTION F-F

TYPE A
INLET ADJACENT TO CURB

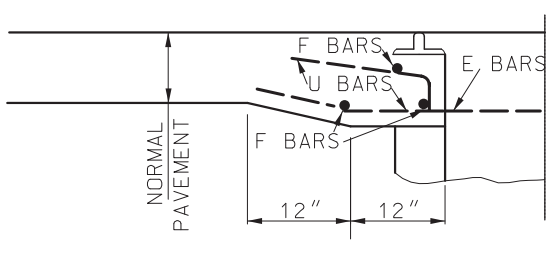

HALF SECTION H-H

TYPE B
DISTANCE BETWEEN BARRIER AND PAVEMENT EDGE GREATER THAN INLET WIDTH

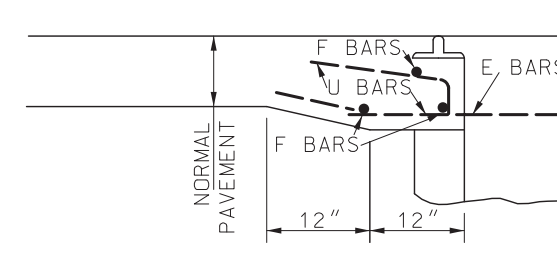

HALF SECTION J-J

TYPE C
DISTANCE BETWEEN BARRIER AND PAVEMENT EDGE EQUAL TO INLET WIDTH

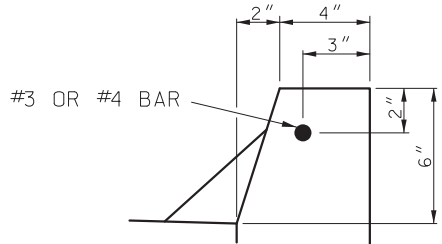

DETAIL A

GENERAL NOTE:

SEE STANDARD PLAN 614.11 FOR CURVED VANE GRATE.



MISSOURI HIGHWAYS AND TRANSPORTATION COMMISSION

105 WEST CAPITOL
JEFFERSON CITY, MO 65102
1-888-ASK-MODOT (1-888-275-6636)



THIS SHEET HAS BEEN SIGNED, SEALED AND DATED ELECTRONICALLY.

PRECAST DROP INLET COVERS

DATE EFFECTIVE: 1/1/2025
DATE PREPARED: 10/4/2024

731.10T

SHEET NO.
3 OF 8

STRUCTURAL SIGN DATA

DESIGNATION	COLOR SCHEME		SHEETING	
	LEGEND	BACKGROUND	LEGEND	BACKGROUND
STRUCTURAL (ST)	BLACK	WHITE	OPAQUE BLACK FILM	ASTM TYPE 4
	WHITE	RED	ASTM TYPE 9 OR 11	ASTM TYPE 4
	WHITE	GREEN	ASTM TYPE 9 OR 11	ASTM TYPE 4
	WHITE	BLUE	ASTM TYPE 9 OR 11	ASTM TYPE 4
	WHITE	BROWN	ASTM TYPE 9 OR 11	ASTM TYPE 4
STRUCTURAL FLUORESCENT (STF)	BLACK	FL YELLOW	OPAQUE BLACK FILM	ASTM TYPE 9 OR 11
	BLACK	FL YELLOW GREEN	OPAQUE BLACK FILM	ASTM TYPE 9 OR 11
	BLACK	FL ORANGE	OPAQUE BLACK FILM	ASTM TYPE 9 OR 11

NOTE: WHITE LEGEND IS DIRECT APPLIED UNLESS SPECIFIED OTHERWISE.

FLAT SHEET SIGN DATA

DESIGNATION	COLOR SCHEME		SHEETING
	LEGEND	BACKGROUND	
FLAT SHEET (SH)	BLACK **	WHITE	ASTM TYPE 4 WHITE
	WHITE	BLACK **	ASTM TYPE 4 WHITE
	RED	WHITE	ASTM TYPE 4 WHITE
	WHITE	RED	ASTM TYPE 4 WHITE
	WHITE	GREEN	ASTM TYPE 4 WHITE
	GREEN	WHITE	ASTM TYPE 4 WHITE
	WHITE	BLUE	ASTM TYPE 4 WHITE
	WHITE	BROWN	ASTM TYPE 4 WHITE
FLAT SHEET FLUORESCENT (SHF)	BLACK **	FL YELLOW	ASTM TYPE 9 OR 11 FL YELLOW
	BLACK **	FL YELLOW GREEN	ASTM TYPE 9 OR 11 FL YELLOW GREEN
	BLACK **	FL ORANGE	ASTM TYPE 9 OR 11 FL ORANGE

** OPAQUE INK OR FILM

NOTE: LEGEND AND BACKGROUND COLORS ARE ACHIEVED THROUGH TRANSLUCENT INKS AND FILMS.

FLAT SHEET THICKNESS	
SIGN SIZE	THICKNESS
9 SF OR LESS	0.080 IN.
OVER 9 SF BUT UNDER 16 SF	0.100 IN.
16 SF OR LARGER	0.125 IN.



GENERAL NOTES:

GROUND MOUNTED SIGNS GREATER THAN 5 FEET WIDE OR GREATER THAN 30 SQUARE FEET SHALL BE STRUCTURAL.

ALL NONSTANDARD SIGNS NOT FOUND IN THE MUTCD SHS MANUAL SHALL BE DETAILED BY THE HIGHWAY SAFETY AND TRAFFIC DIVISION OFFICE.

REFER TO STANDARD SPECIFICATION SEC 1042 FOR SHEETING, SUBSTRATE AND FABRICATION DETAILS.

FOR MOUNTING DETAILS, SEE STANDARD PLAN 903.02.

	MISSOURI HIGHWAYS AND TRANSPORTATION COMMISSION 105 WEST CAPITOL JEFFERSON CITY, MO 65102 1-888-ASK-MODOT (1-888-275-6636)	
		<h2>HIGHWAY SIGNING</h2> <h3>GENERAL SIGN DATA</h3>
DATE EFFECTIVE: 1/1/2025 DATE PREPARED: 10/4/2024	<h1>903.02AQ</h1>	SHEET NO. 1 OF 8

STATE NUMBER ROUTE SHIELD
GUIDE SIGN USE

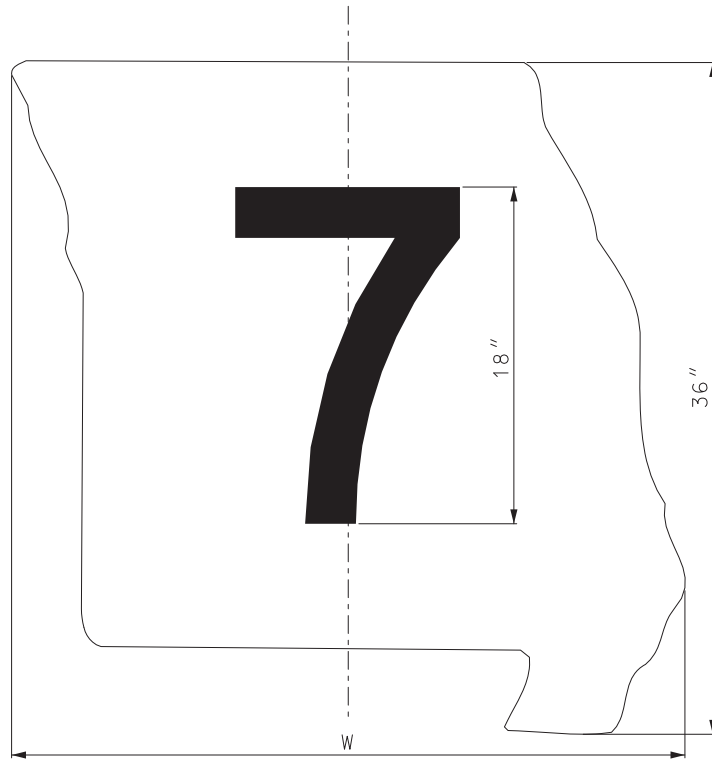

STATE LETTER ROUTE SHIELD
GUIDE SIGN USE

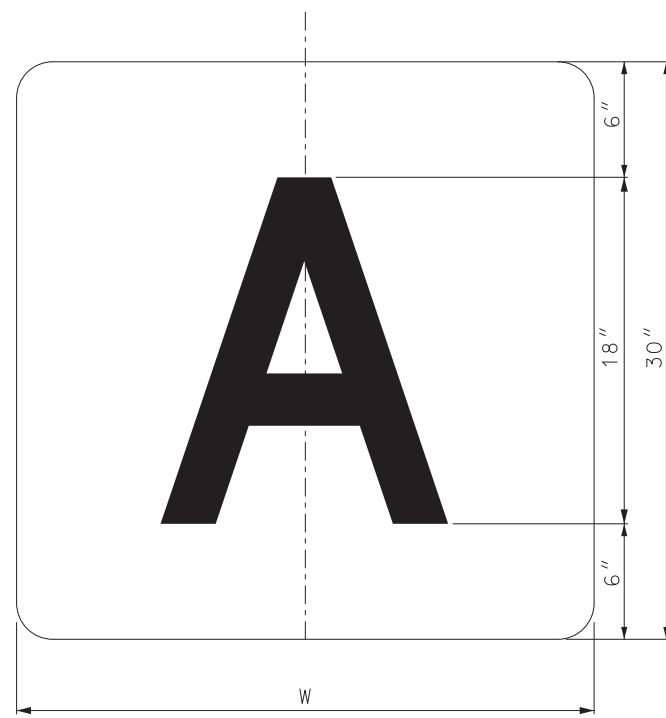

STATE NUMBER ROUTE SHIELD
INDEPENDENT USE

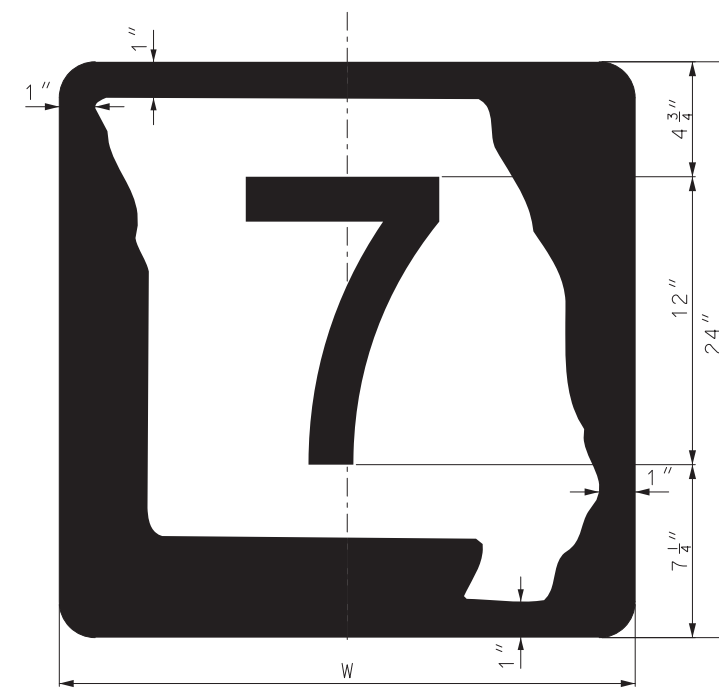

STATE LETTER ROUTE SHIELD
INDEPENDENT USE

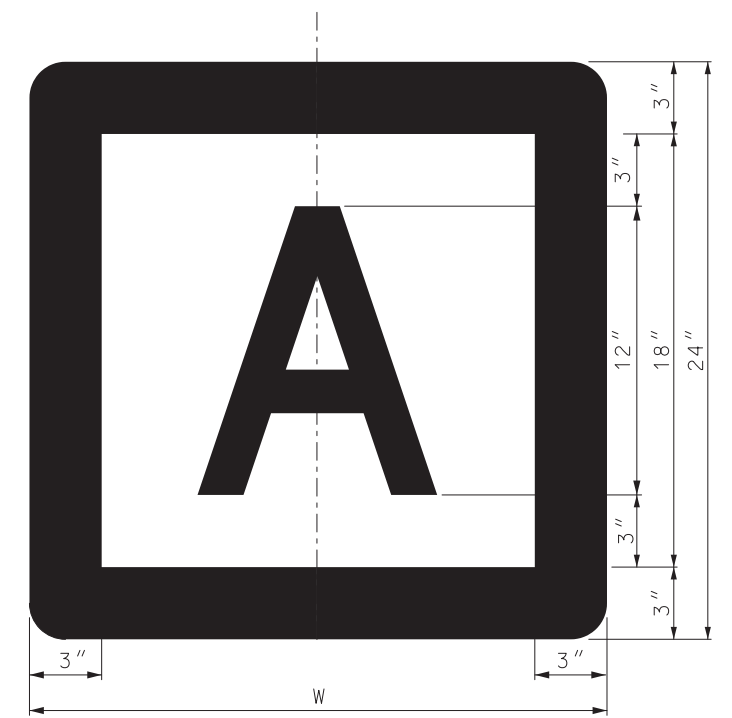

LOCATION	ROUTE NUMBER	WIDTH (INCHES)	LEGEND FONTS
INDEPENDENT USE	1 & 2 DIGITS	24	D,C
INDEPENDENT USE	3 DIGITS	30	D,C,B
GUIDE SIGN USE	1 & 2 DIGITS	36	D,C
GUIDE SIGN USE	3 DIGITS	45	D,C,B

STATE NUMBER ROUTE SHIELD



LOCATION	NO. OF LETTERS	WIDTH (INCHES)	LEGEND FONTS
INDEPENDENT USE	1	24	D
INDEPENDENT USE	2	30	D
GUIDE SIGN USE	1	30	D
GUIDE SIGN USE	2	36	D

STATE LETTER ROUTE SHIELD



GENERAL NOTES:

REFER TO STANDARD SPECIFICATION SEC 1042 FOR SHEETING AND SUBSTRATE DETAILS.

FOR HOLE PUNCHING AND MOUNTING DETAILS, SEE OTHER DRAWINGS.

FOR GENERAL SIGN DATA DETAILS, SEE OTHER DRAWINGS.

THE MISSOURI SHAPE DETAIL MAY BE OBTAINED FROM THE HIGHWAY SAFETY AND TRAFFIC DIVISION OFFICE.

GUIDE SIGN USE SHALL BE DIRECT APPLIED. POST MOUNTED USE SHALL BE APPLIED TO ALUMINUM SUBSTRATE.

FOR NUMBERED ROUTES WITH MORE THAN 1 DIGIT THE LEGEND FONT MAY NEED TO BE REDUCED TO C OR B FONT.

SEE MUTCD SHS FOR DETAILS FOR US AND INTERSTATE ROUTE SHIELDS.

NONSTANDARD SHIELD SIZES MAY BE OBTAINED FROM THE HIGHWAY SAFETY AND TRAFFIC DIVISION OFFICE.

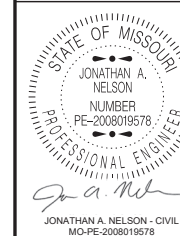
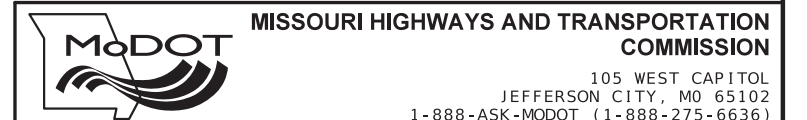

HIGHWAY SIGNING
STANDARD SHIELDS FOR
INDEPENDENT AND GUIDE
SIGN USE

DATE EFFECTIVE: 1/1/2025
DATE PREPARED: 10/4/2024

903.02AQ

SHEET NO.
3 OF 8

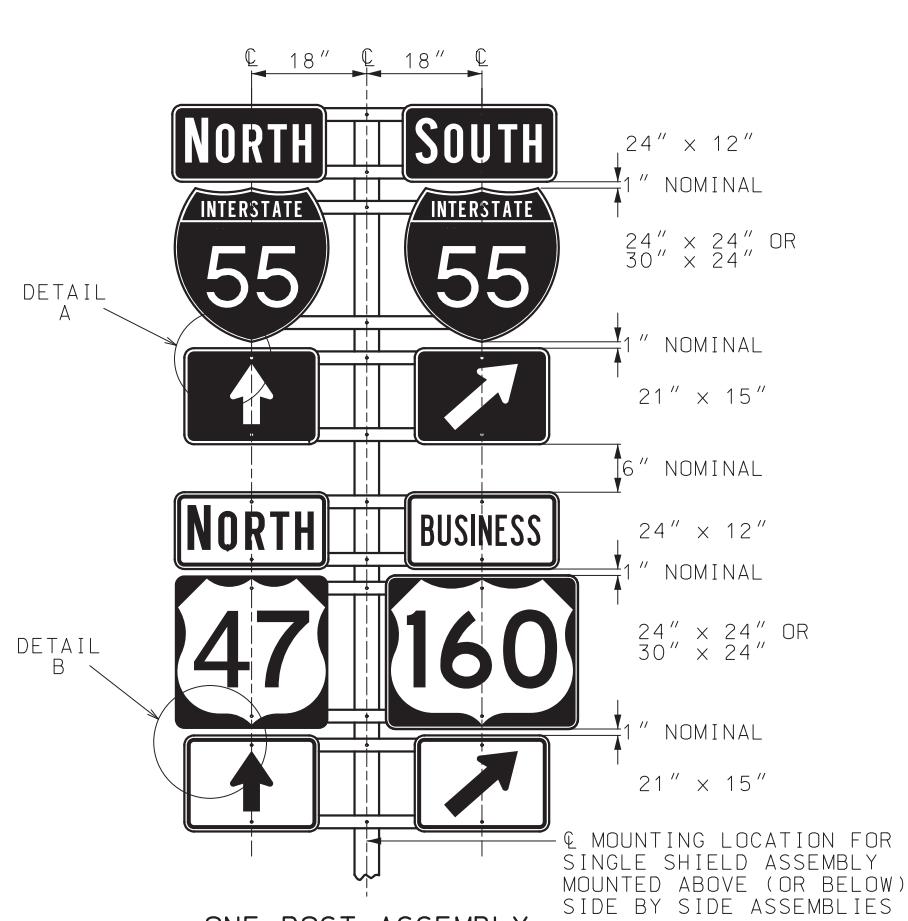

ONE POST ASSEMBLY

USE TO SUPPORT UP TO 4 ROUTE MARKERS

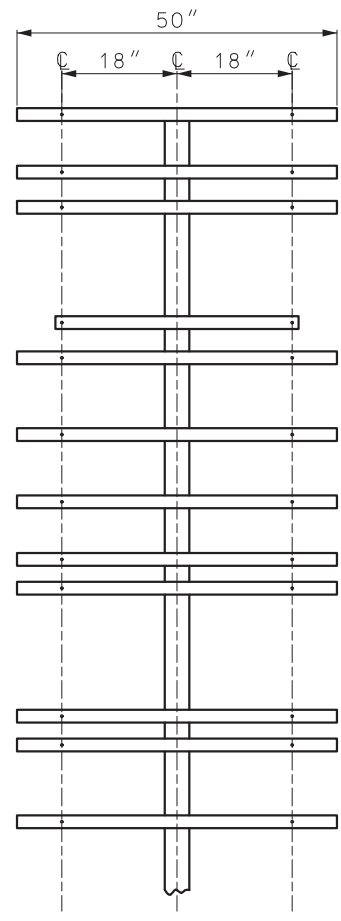

STANDARD BACKING BAR LAYOUT

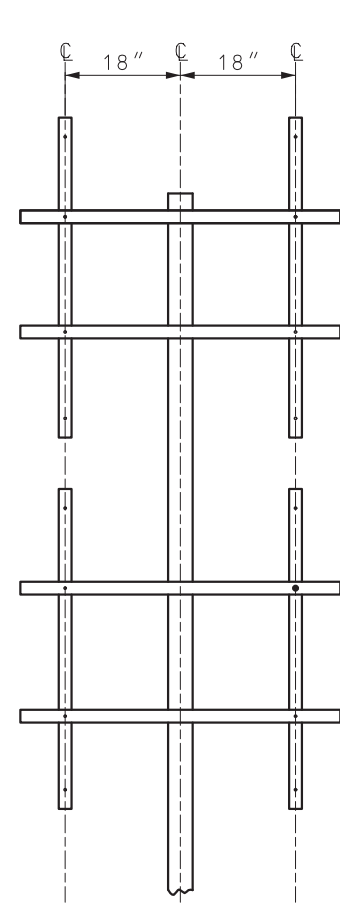

OPTIONAL BACKING BAR LAYOUT

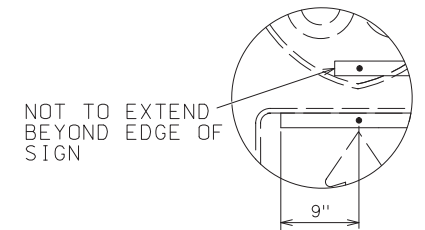

DETAIL A
SEE GENERAL NOTES

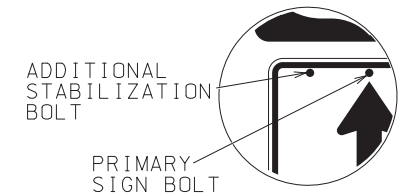

DETAIL B
SEE GENERAL NOTES

GENERAL NOTES:

ALL BACKING BARS SHALL BE 2" x 3/8" STEEL, GALVANIZED AFTER PUNCHING. WEIGHT = 2.55 LBS. PER FOOT. HOLES IN BARS SHALL BE 3/8" AND SHALL BE PUNCHED AS SHOWN ON THIS DRAWING.

DETAIL A - THE END OF THE HORIZONTAL BACKING BARS SHALL EXTEND MAXIMUM OF 9 INCHES PAST THE SIGN BOLT, BUT SHALL NOT EXTEND PAST THE EDGE OF THE SIGN.

DETAIL B - FOR SIGNS INSTALLED ON TWO PARALLEL HORIZONTAL BACKING BARS, ONE ADDITIONAL BOLT SHALL BE ADDED TO THE LEFT SIGN TO KEEP ASSEMBLY SQUARE.

WHEN USING OPTIONAL BACKING BAR LAYOUT, VERTICAL BARS SHALL BE MOUNTED BEHIND HORIZONTAL BARS.

BACKING BARS SHALL MEET MISSOURI STANDARD PLANS OR APPROVED PRODUCTS LIST.

ALL SIGNS TO BE INSTALLED ALONG VERTICAL CENTERLINES.

FOR POST AND FOOTING DATA AND DETAILS OF SHIELDS AND PLAQUES, SEE OTHER DRAWINGS.

NOMINAL VERTICAL SPACING INDICATED BETWEEN SIGNS TO BE ACHIEVED BY USING THE CLOSEST AVAILABLE HOLES WHEN USING PSST.

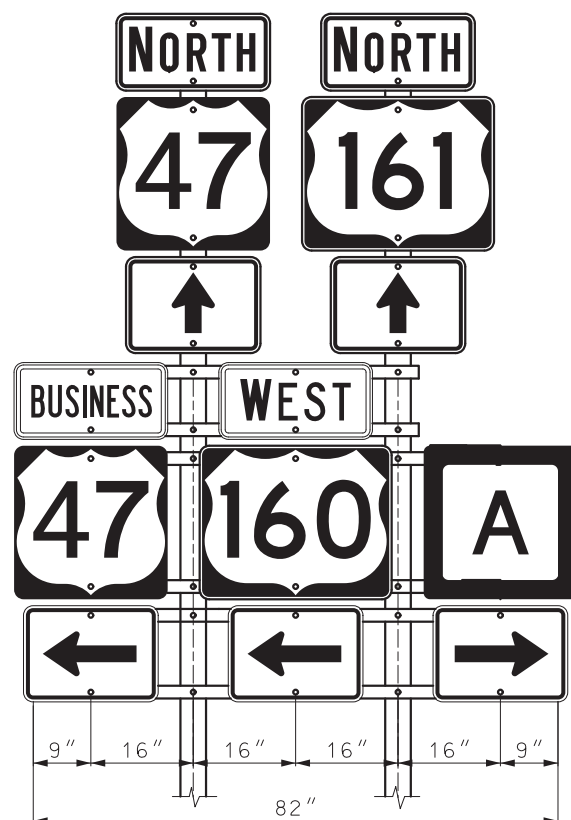

TWO POST ASSEMBLY

USE TO SUPPORT 5 OR 6 ROUTE MARKERS

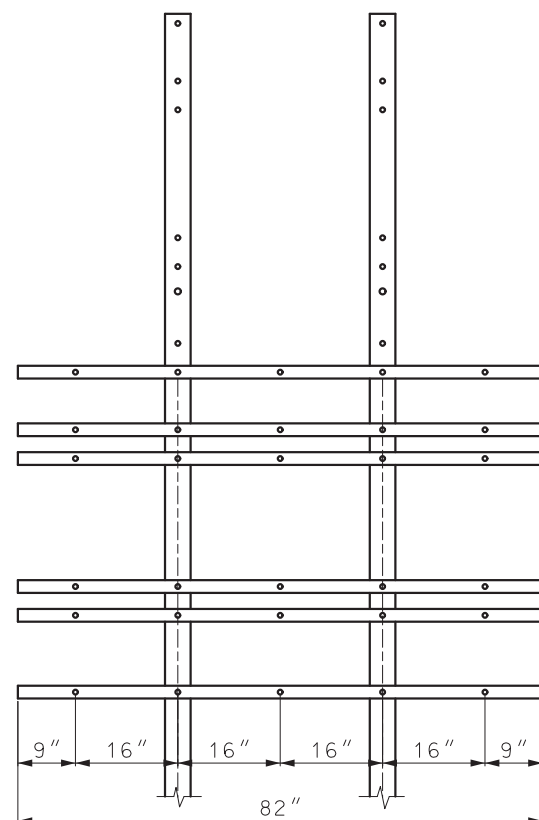

STANDARD BACKING BAR LAYOUT

TWO POST ASSEMBLY NOTE:

OPTIONAL BACKING BAR LAYOUT MAY BE USED WITH TWO POST ASSEMBLY.

FOR 6 ROUTE SHIELD ASSEMBLY ADDITIONAL BACKING BARS ARE REQUIRED.

POST SELECTION:

SINGLE POST ASSEMBLIES SHALL USE A 4" PIPE POST OR A 2 1/2" PSST POST.

TWO POST ASSEMBLIES SHALL USE TWO 4" PIPE POSTS OR TWO 2 1/2" PSST POSTS WITH 2 1/4" PSST INSERTS AND BREAKAWAYS. (SEE STANDARD PLAN 903.03)

MoDOT MISSOURI HIGHWAYS AND TRANSPORTATION COMMISSION
 105 WEST CAPITOL JEFFERSON CITY, MO 65102
 1-888-ASK-MODOT (1-888-275-6636)

STATE OF MISSOURI
 JONATHAN A. NELSON
 NUMBER PE-2008019578
 PROFESSIONAL ENGINEER
 Jonathan A. Nelson - CIVIL
 MO-PE-2008019578

**HIGHWAY SIGNING
 BACKING BARS
 SHEET SIGN MOUNTING
 ROUTE SHIELD AND
 MARKER ASSEMBLIES**

DATE EFFECTIVE: 1/1/2025	903.02AQ	SHEET NO. 4 OF 8
DATE PREPARED: 10/4/2024		

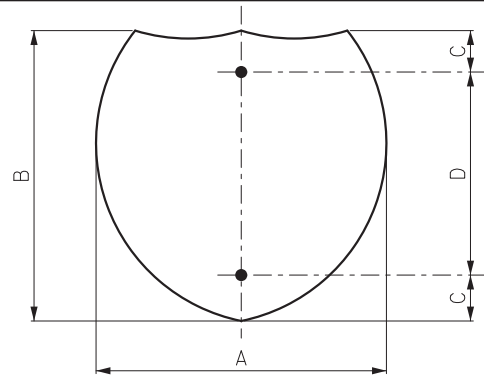

DIMENSIONS (IN.)			
A	B	C	D
24	24	3	18
30	24	3	18
36	36	6	24
45	36	6	24

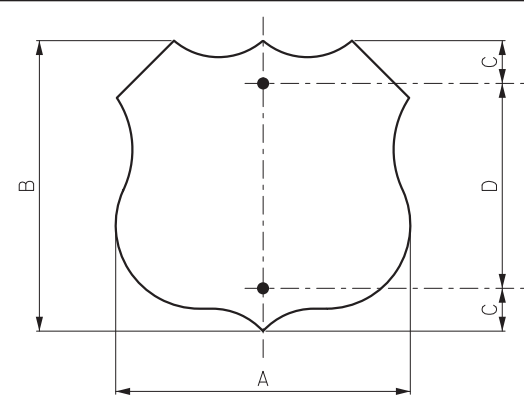

DIMENSIONS (IN.)			
A	B	C	D
24	24	3	18
30	24	3	18
36	36	6	24
45	36	6	24

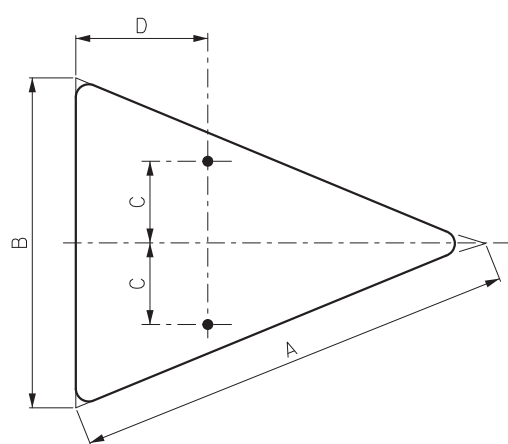
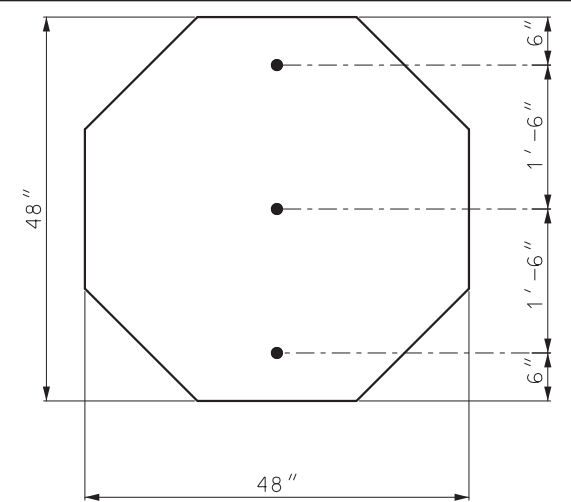
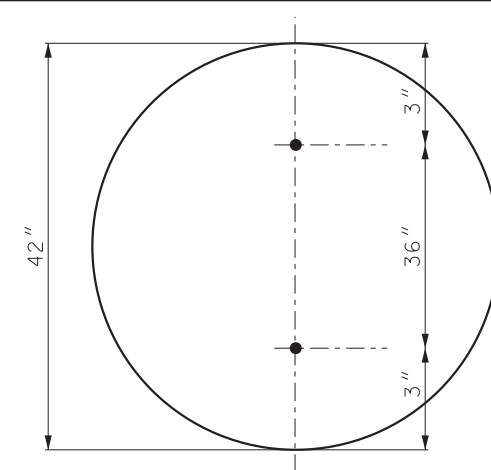

DIMENSIONS (IN.)				
A	B	C	D	RADIUS
40	30	7.5	12	1.875
48	36	9	15	2.25

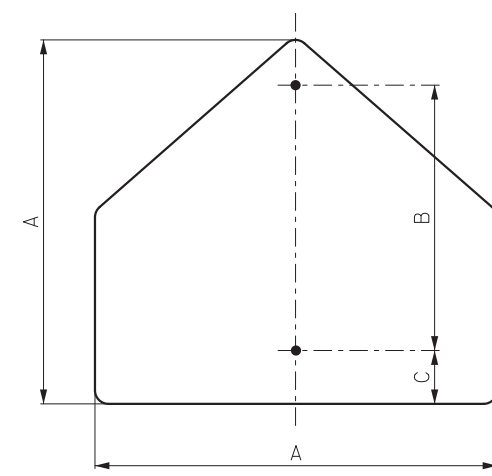

DIMENSIONS (IN.)			
A	B	C	RADIUS
36	24	3	2.25

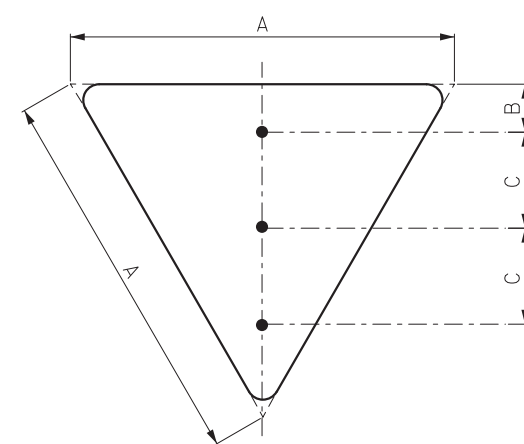

DIMENSIONS (IN.)			
A	B	C	RADIUS
48	6	12	3
60	8	15	4

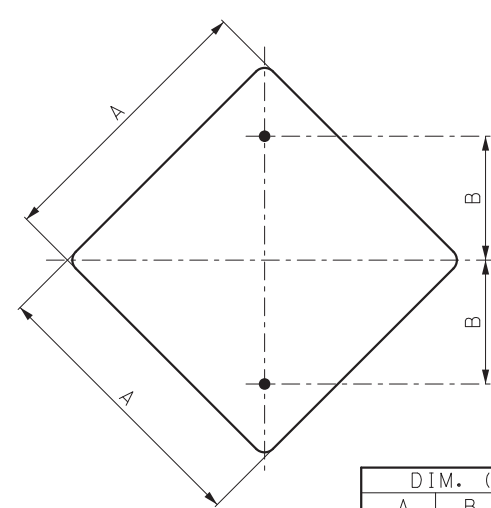
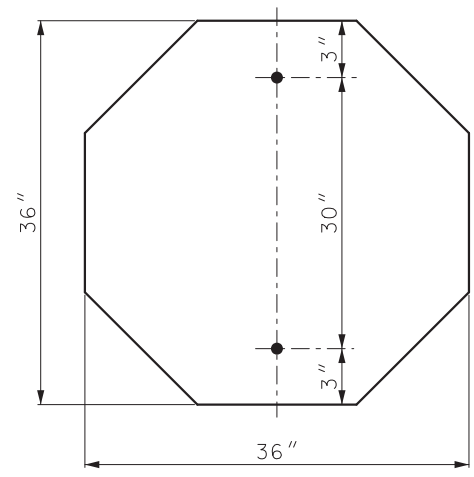

DIM. (IN.)		
A	B	RADIUS
18	9	1.5
24	12	1.5
30	15	1.875
36	18	2.25

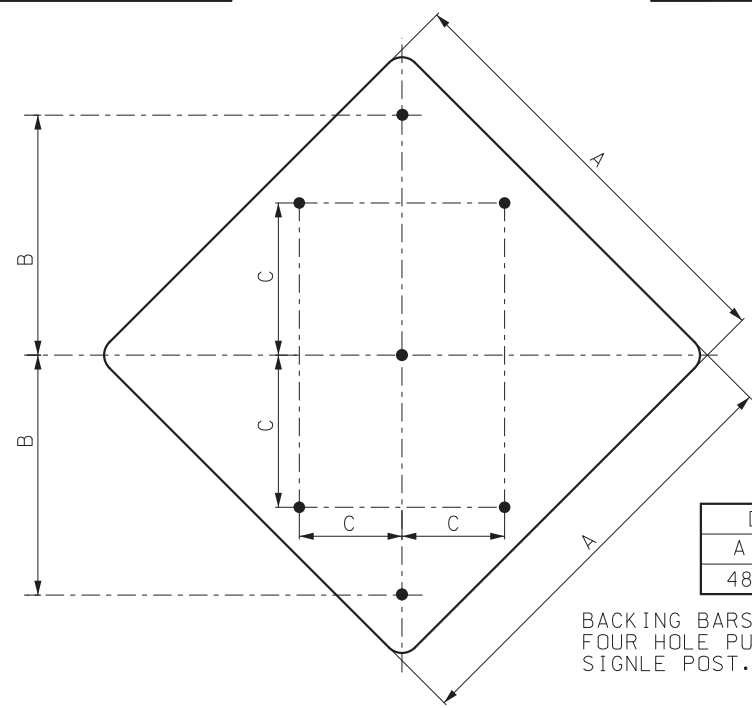

DIMENSIONS (IN.)			
A	B	C	RADIUS
48	24	15	3

BACKING BARS ONLY REQUIRED FOR FOUR HOLE PUNCH INSTALLATION ON SINGLE POST.

GENERAL NOTES:

SIGNS WITH FOUR OR MORE HOLES REQUIRE BACKING BARS OR MULTIPLE POSTS.

HOLES IN SIGNS SHALL BE $\frac{3}{8}$ " AND PUNCHED AS SHOWN ON THIS DRAWING.

FLAT SHEET FOR SIGNS SHALL BE THE FOLLOWING THICKNESS:

- 9 SQUARE FEET OF LESS = 0.080 IN.
- OVER 9 BUT UNDER 16 SQUARE FEET = 0.100 IN.
- 16 SQUARE FEET OR LARGER = 0.125 IN.

FOR MOUNTING DETAILS, SEE OTHER DRAWINGS.

MoDOT MISSOURI HIGHWAYS AND TRANSPORTATION COMMISSION
 105 WEST CAPITOL JEFFERSON CITY, MO 65102
 1-888-ASK-MODOT (1-888-275-6636)

STATE OF MISSOURI
 JONATHAN A. NELSON
 NUMBER PE-2008019578
 PROFESSIONAL ENGINEER
 Jonathan A. Nelson
 JONATHAN A. NELSON - CIVIL
 MO-PE-2008019578

HIGHWAY SIGNING
HOLE PUNCHING

DATE EFFECTIVE: 1/1/2025
 DATE PREPARED: 10/4/2024

903.02AQ

SHEET NO.
 6 OF 8

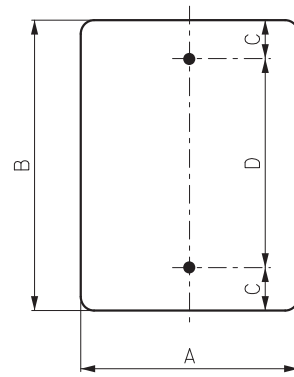

DIMENSIONS (IN.)				
A	B	C	D	RADIUS
4	16	0.75	14.5	SQ
6	12	1.5	9	1
9	12	3.5	5	1.5
9	15	3.75	7.5	1.5
12	18	3	12	1.5
12	24	3	18	1.5
12	36	3	30	1.5
12	48	3	42	1.5
15	21	3	15	1.5
18	24	3	18	1.5
24	30	3	24	1.5
24	36	3	30	1.5
30	36	3	30	1.875
30	42	3	36	1.875
30	48	6	36	1.875

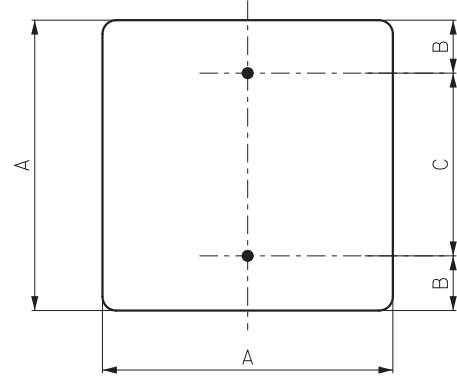

DIMENSIONS (IN.)			
A	B	C	RADIUS
12	1.5	9	1.5
18	3	12	1.5
24	3	18	1.5
30	3	24	1.875
36	6	24	2.25

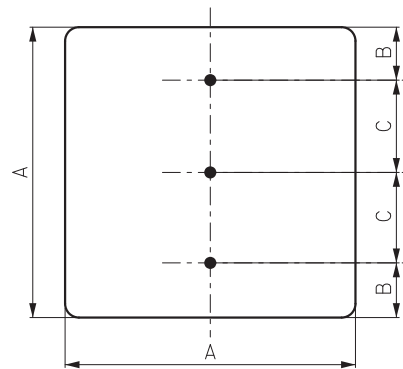

DIMENSIONS (IN.)			
A	B	C	RADIUS
48	6	18	3

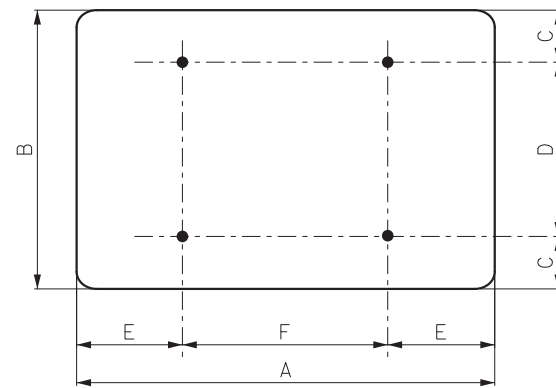

DIMENSIONS (IN.)						
A	B	C	D	E	F	RADIUS
48	12	1.5	9	9	30	1.5
48	18	1.5	15	9	30	1.5
48	24	3	18	9	30	1.5
48	30	3	24	9	30	1.875
48	36	6	24	9	30	2.25
54	18	1.5	15	9	36	1.5
60	12	1.5	9	12	36	1.5
60	18	1.5	15	12	36	1.5
60	24	3	18	12	36	1.5
60	30	3	24	12	36	1.875
60	36	6	24	12	36	2.25
60	48	6	36	12	36	3
72	36	6	24	12	48	2.25
72	48	6	36	12	48	3

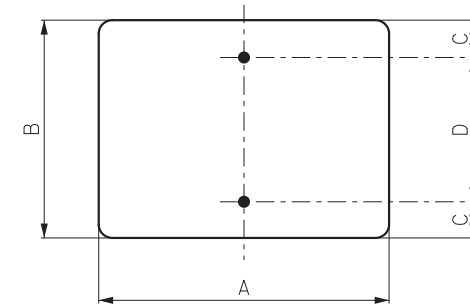

DIMENSIONS (IN.)				
A	B	C	D	RADIUS
4	5	1.5	2	1.5
12	9	1.5	6	1.5
18	9	1.5	6	1.5
18	12	1.5	9	1.5
21	15	1.5	12	1.5
24	8	1.5	5	1.5
24	12	1.5	9	1.5
24	18	3	12	1.5
30	8	1.5	5	1.5
30	12	1.5	9	1.5
30	18	3	12	1.5
30	24	3	18	1.5
36	8	1.5	5	1.5
36	12	1.5	9	1.5
36	18	3	12	1.5
36	24	3	18	1.5
36	30	3	24	1.875
42	8	1.5	5	1.5
42	18	3	12	1.5
42	24	3	18	1.5
42	30	3	24	1.875
42	36	3	30	2.25
48	8	1.5	5	1.5

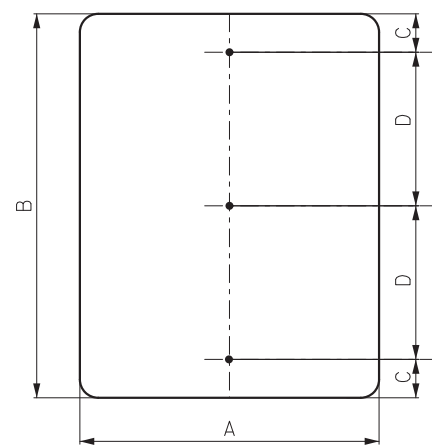

DIMENSIONS (IN.)				
A	B	C	D	RADIUS
4	72	6	30	SQ
12	72	6	30	1.5
18	60	6	24	1.5
24	48	6	18	1.5
36	48	6	18	2.25
36	60	6	24	2.25
36	72	6	30	2.25

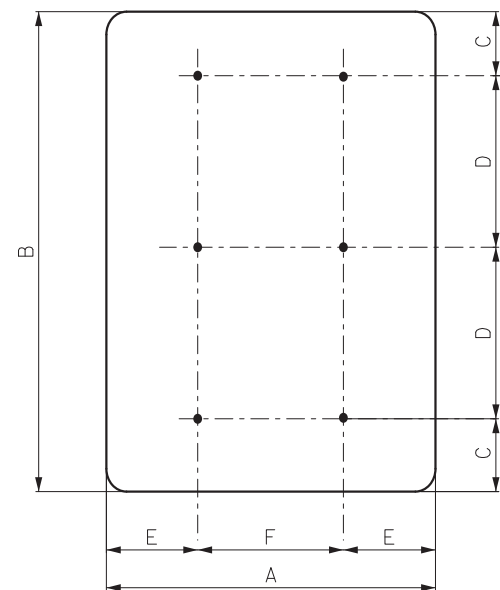

DIMENSIONS (IN.)						
A	B	C	D	E	F	RADIUS
48	60	6	24	9	30	3
48	72	6	30	9	30	3
48	84	6	36	9	30	3
48	96	6	42	9	30	3

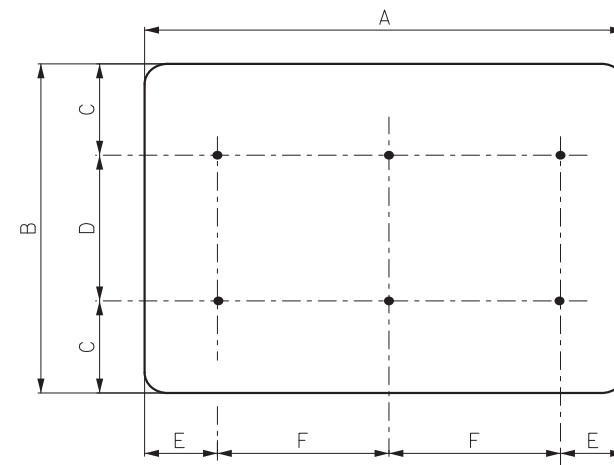

DIMENSIONS (IN.)						
A	B	C	D	E	F	RADIUS
84	24	3	18	12	30	3
96	48	6	36	16	32	3

DIMENSIONS (IN.) FOR SIGNS REQUIRING NO HOLE PUNCHING		
A	B	RADIUS
66	18	1.5
72	18	1.5
78	18	1.5
84	18	1.5
90	18	1.5
96	18	1.5
36	78	2.25

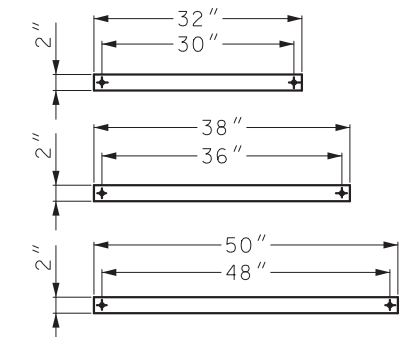

BACKING BARS FOR SINGLE POST SIGNS

GENERAL NOTES:

REFER TO GENERAL NOTES ON SHEET 6 OF 8.

MoDOT MISSOURI HIGHWAYS AND TRANSPORTATION COMMISSION
 105 WEST CAPITOL JEFFERSON CITY, MO 65102
 1-888-ASK-MODOT (1-888-275-6636)

STATE OF MISSOURI
 JONATHAN A. NELSON
 NUMBER PE-2008019578
 PROFESSIONAL ENGINEER
 Jonathan A. Nelson
 JONATHAN A. NELSON - CIVIL
 MO-PE-2008019578

HIGHWAY SIGNING
HOLE PUNCHING

DATE EFFECTIVE: 1/1/2025
 DATE PREPARED: 10/4/2024

903.02AQ

SHEET NO.
 7 OF 8

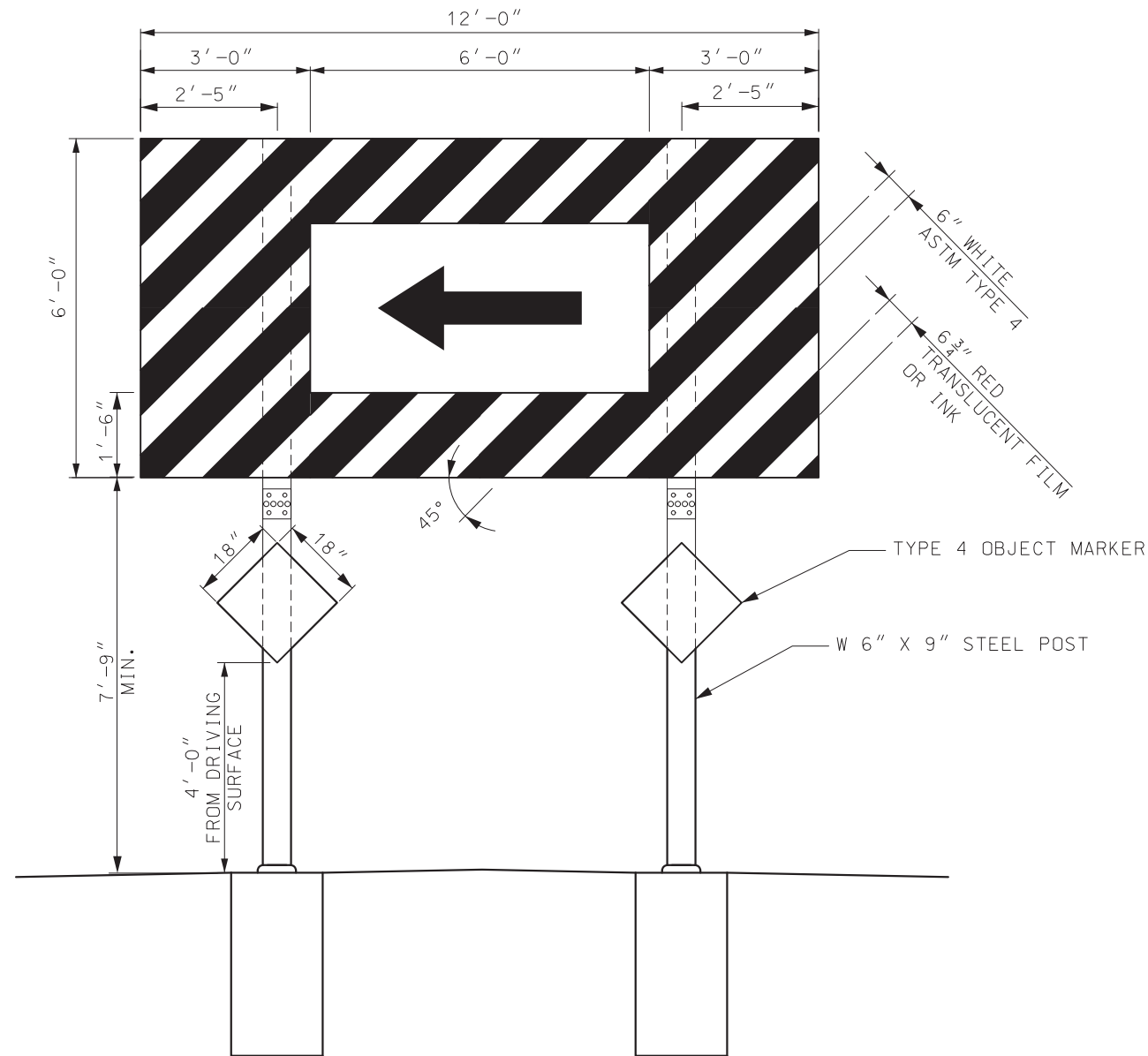

SEE STANDARD PLAN 903.03
FOR MOUNTING HEIGHT ON UNLEVEL GROUND

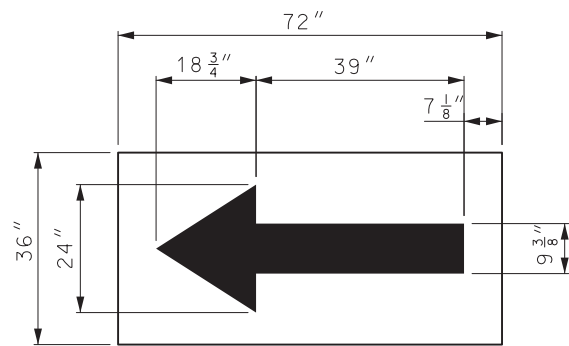

W1-6

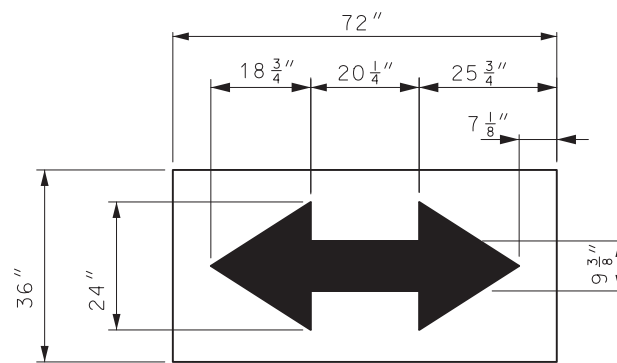

W1-7

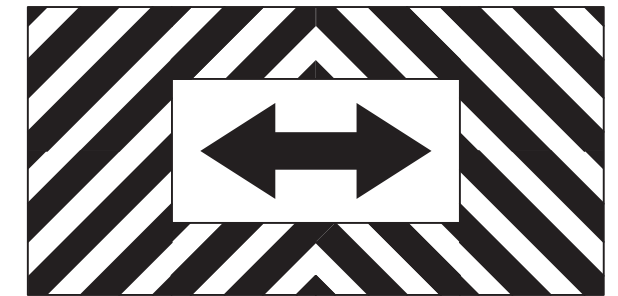
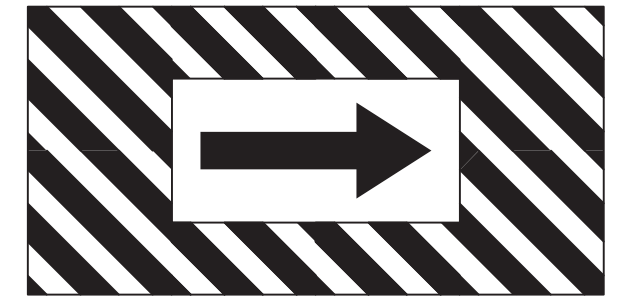

T-INTERSECTION



DEAD END

GENERAL NOTES:

SEE STANDARD PLAN 903.03 FOR WIDE FLANGE INSTALLATION.

SIGN BARRICADE SHALL BE CONSTRUCTED AS A STRUCTURAL (ST) SIGN.

DIRECTIONAL ARROWS SHALL BE FLAT SHEET FLUORESCENT (SHF) AND CONSIDERED INCIDENTAL TO THE SIGN.

ALL REFLECTORIZED SURFACES SHALL BE RETROREFLECTIVE SHEETING IN ACCORDANCE WITH SEC 1042.

	MISSOURI HIGHWAYS AND TRANSPORTATION COMMISSION 105 WEST CAPITOL JEFFERSON CITY, MO 65102 1-888-ASK-MODOT (1-888-275-6636)	
	HIGHWAY SIGNING SIGN BARRICADE	
	DATE EFFECTIVE: 1/1/2025 DATE PREPARED: 10/4/2024	903.02AQ
		SHEET NO. 8 OF 8

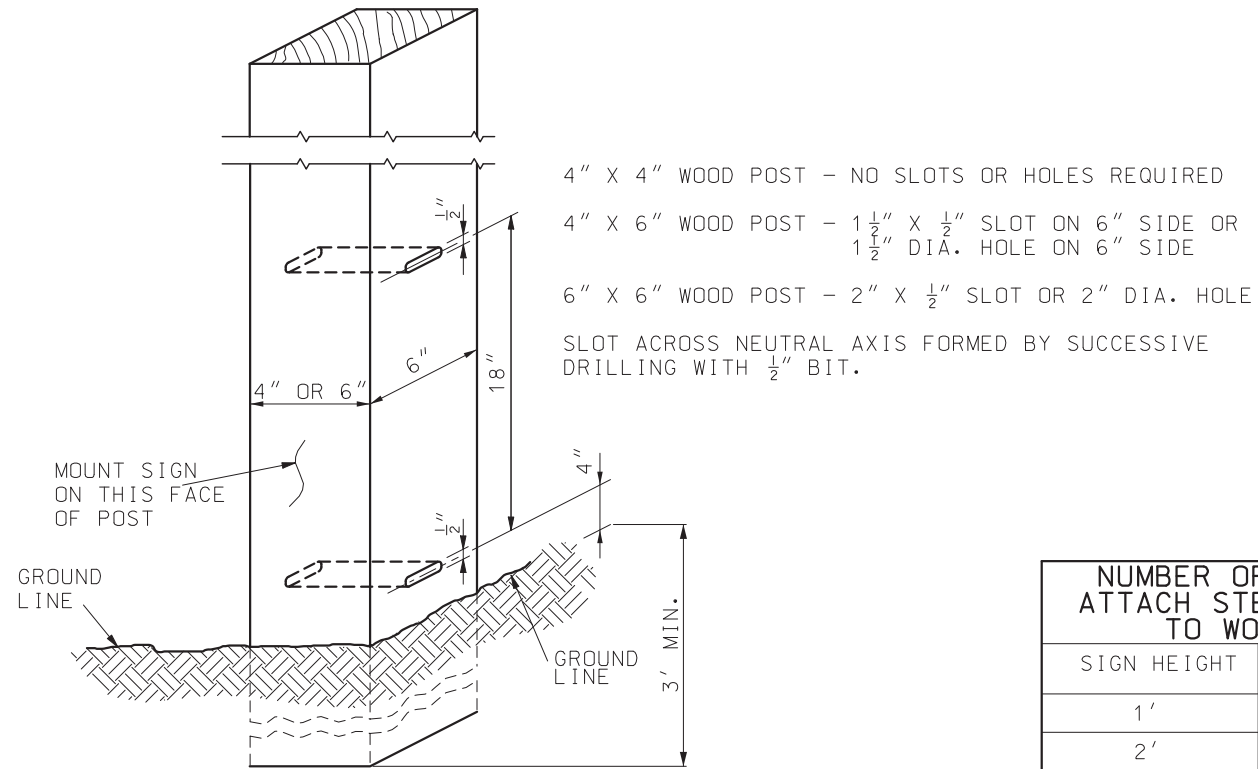

WOOD POST DETAIL

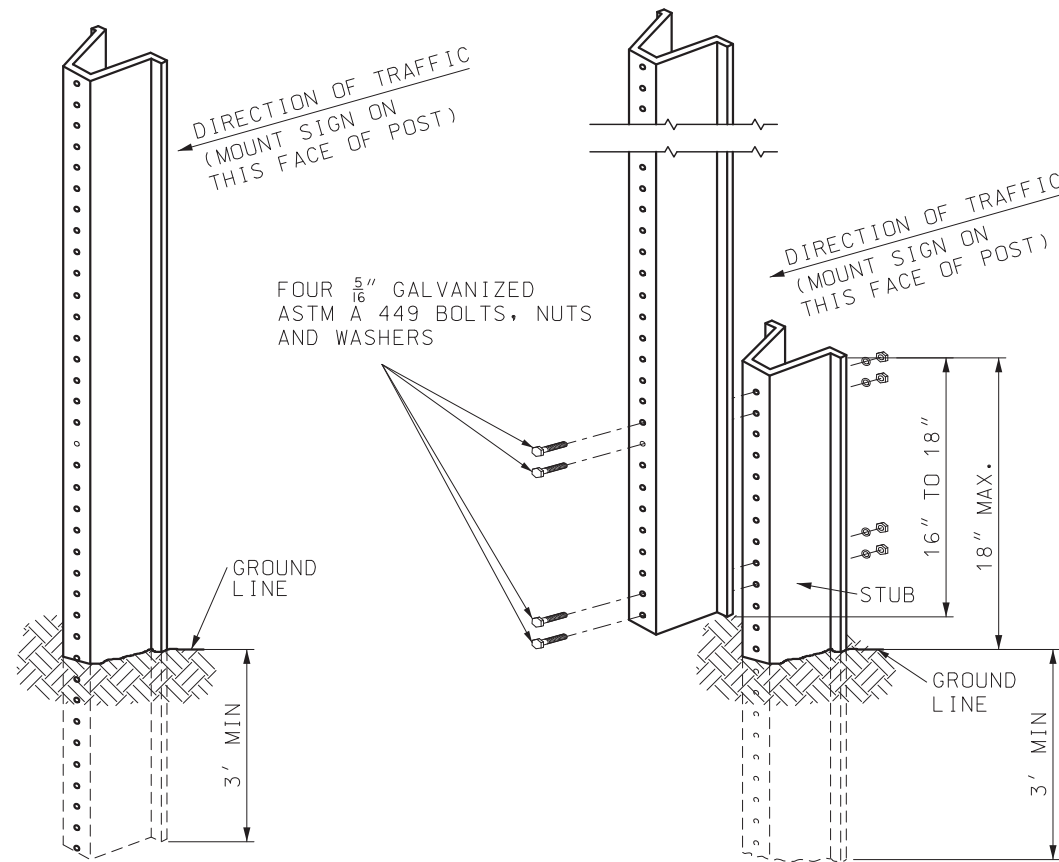

U-CHANNEL POST-STUB DETAIL

U-CHANNEL POST DETAIL OPTIONAL INSTALLATION

NUMBER OF BOLTS TO ATTACH STEEL CHANNEL TO WOOD POST	
SIGN HEIGHT	NO. OF BOLTS PER WOOD POST USED
1'	2
2'	3
3'	4
4'	5
5'	6
6'	7
7'	8

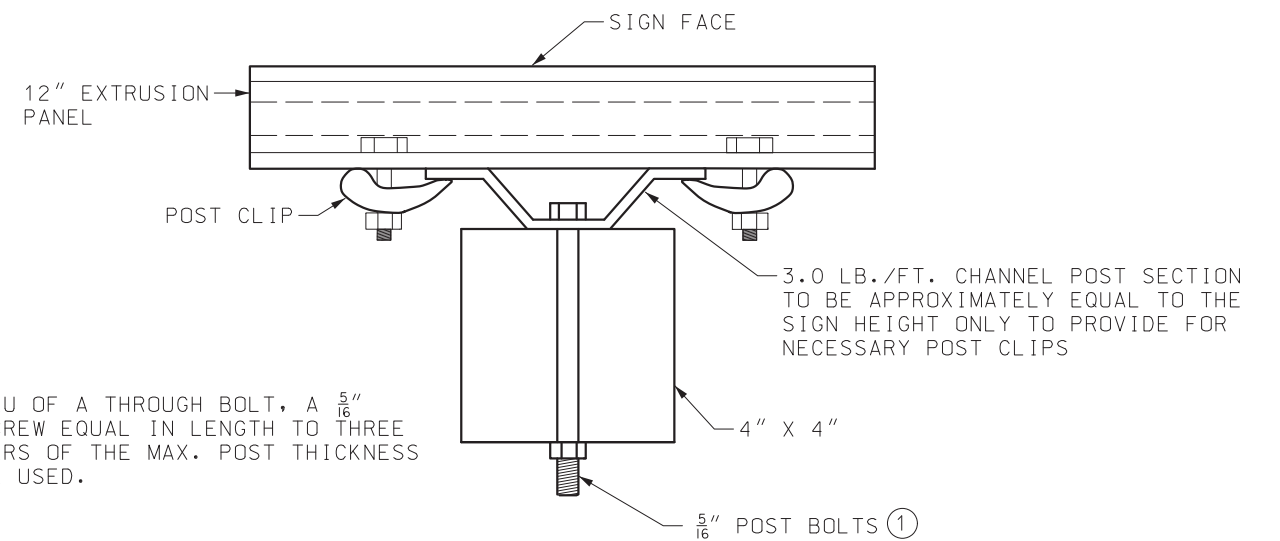

PLAN VIEW

MOUNTING DETAILS FOR EXTRUDED PANELS ON WOOD POST

① IN LIEU OF A THROUGH BOLT, A 5/16" LAG SCREW EQUAL IN LENGTH TO THREE QUARTERS OF THE MAX. POST THICKNESS MAY BE USED.

NOTES:

FOR GENERAL NOTES, SEE SHEET 1 OF 16.

ALL POSTS SHALL BE EMBEDDED A MINIMUM OF 3 FEET INTO THE GROUND.

U-CHANNEL POST-STUB OVERLAP SHALL BE POSITIONED ENTIRELY BETWEEN GROUND LINE AND 18" ABOVE GROUND LINE.

FOR POST CLIP DETAILS, SEE STANDARD PLAN 903.02.

FOR MOUNTING HEIGHT AND OFFSET DETAILS, SEE SHEET 10 OF 16.

SIGN AREA (SQ.FT.)	POST TYPE	
	U-CHANNEL	WOOD
≤ 10	1 - 3.0 LB./FT.*	1 - 4" X 4"*
> 10 ≤ 16	2 - 3.0 LB./FT.	2 - 4" X 4" 1 - 4" X 6"*
> 16 ≤ 24	2 - 3.0 LB./FT.	2 - 4" X 6"
> 24 ≤ 30	3 - 3.0 LB./FT.	2 - 4" X 6"
> 30 ≤ 50	N/A	2 - 6" X 6"

* SIGNS GREATER THAN 4 FEET IN WIDTH REQUIRE TWO POSTS, EXCEPT DIAMOND SHAPED WARNING SIGNS, YIELD SIGNS, AND ONE WAY SIGNS.

POST SIZE REQUIREMENTS

MoDOT MISSOURI HIGHWAYS AND TRANSPORTATION COMMISSION
 105 WEST CAPITOL JEFFERSON CITY, MO 65102
 1-888-ASK-MODOT (1-888-275-6636)

STATE OF MISSOURI
 JONATHAN A. NELSON
 NUMBER PE-2008019578
 PROFESSIONAL ENGINEER
 Jonathan A. Nelson
 JONATHAN A. NELSON - CIVIL
 MO-PE-2008019578

SIGN MOUNTING DETAILS
 WOOD AND U-CHANNEL POST

DATE EFFECTIVE: 1/1/2025
 DATE PREPARED: 8/29/2024

903.03BS

SHEET NO.
 9 OF 16

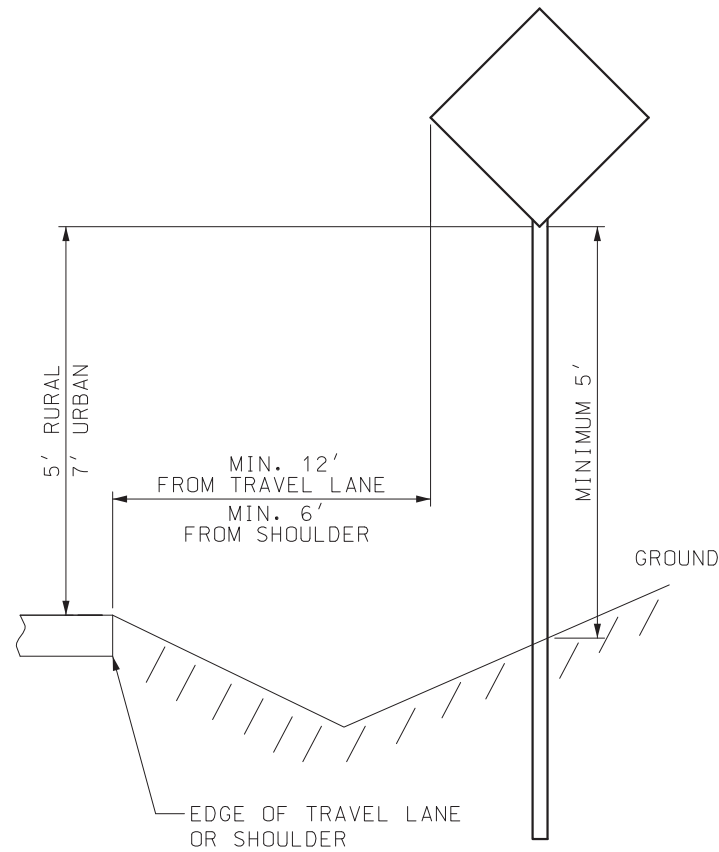

ONE POST - SINGLE SIGN

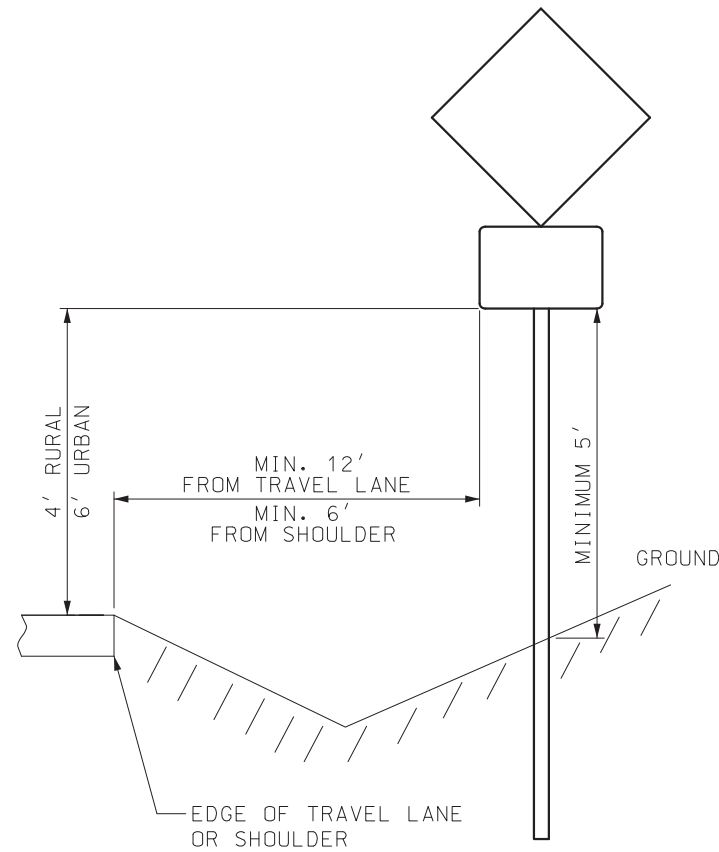

ONE POST - SINGLE SIGN WITH SUPPLEMENTAL PLAGUE

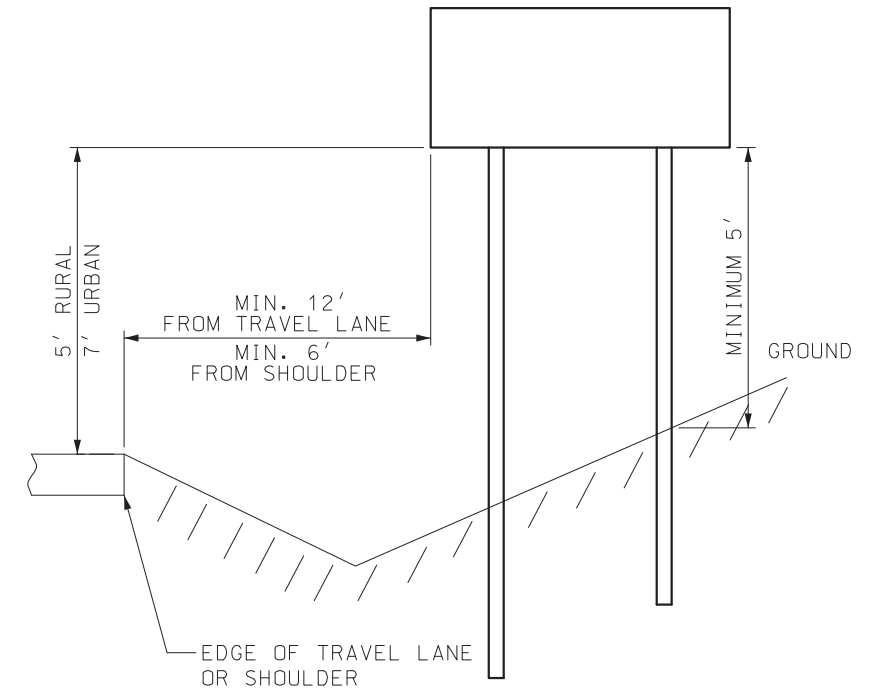

TWO POST

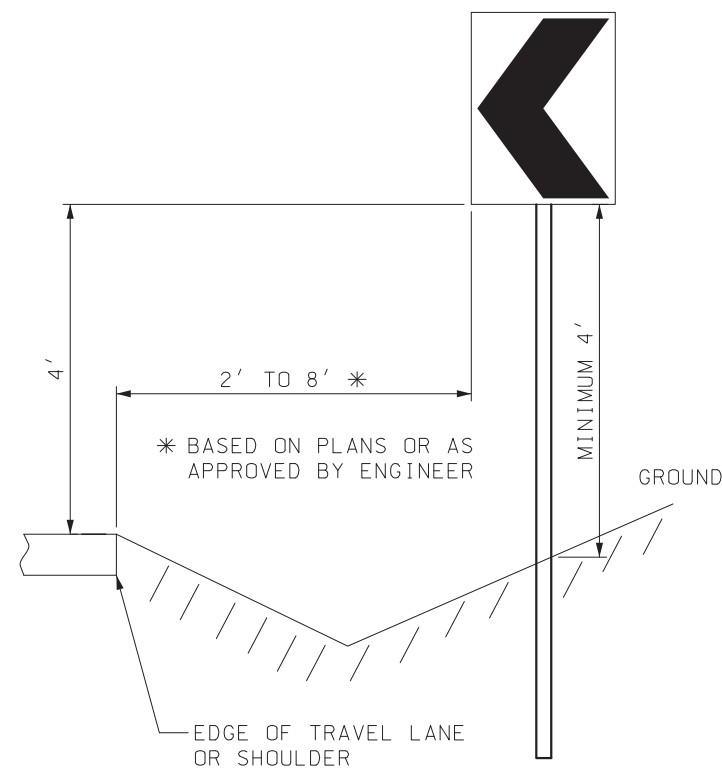

CHEVRON SIGN

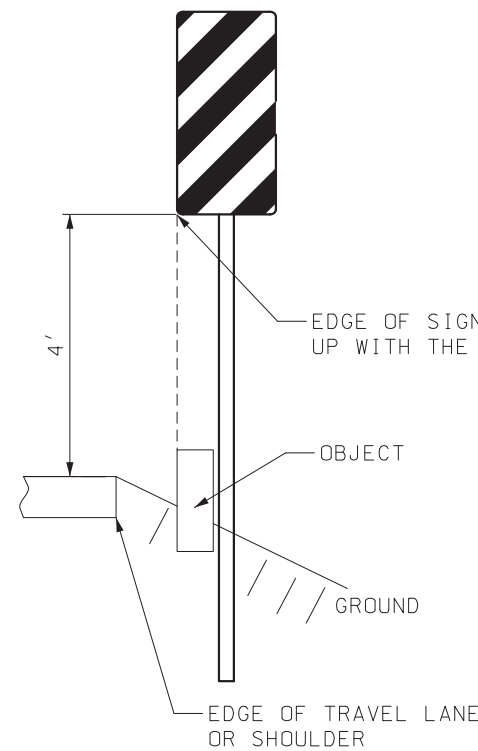

TYPE 3 OBJECT MARKER

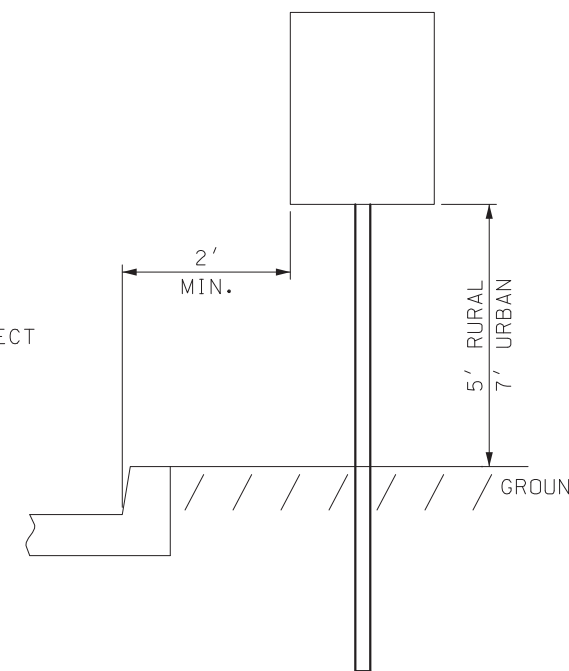

ADJACENT TO CURB

GENERAL NOTES:

SIGN MOUNTING BOLTS SHALL BE INSTALLED WITH A NYLON WASHER AGAINST THE SIGN FACE WITH A STEEL WASHER BETWEEN THE NYLON WASHER AND BOLT HEAD.

A LOCKNUT SHALL BE USED TO FASTEN THE SIGN TO THE POST.

VERTICAL CLEARANCE FROM THE ROADWAY SHALL BE MET AND INCREASED ONLY TO MEET THE MINIMUM VERTICAL CLEARANCE FROM THE GROUND.

HORIZONTAL OFFSET MAY BE ADJUSTED BASED ON FIELD CONDITIONS.

MoDOT MISSOURI HIGHWAYS AND TRANSPORTATION COMMISSION
 105 WEST CAPITOL JEFFERSON CITY, MO 65102
 1-888-ASK-MODOT (1-888-275-6636)

STATE OF MISSOURI
 JONATHAN A. NELSON
 NUMBER PE-2008019578
 PROFESSIONAL ENGINEER
 Jonathan A. Nelson
 JONATHAN A. NELSON - CIVIL
 MO-PE-2008019578

SIGN MOUNTING DETAILS
 MOUNTING HEIGHT & OFFSET
 PIPE POSTS, PSST, WOOD
 & U-CHANNEL POSTS

DATE EFFECTIVE:	1/1/2025	903.03BS	SHEET NO. 10 OF 16
DATE PREPARED:	8/29/2024		

MOUNTING HEIGHT DETAILS