

DESIGN DESIGNATION

A.A.D.T. - 2025 = 527
 A.A.D.T. - 2045 = 736
 D.H.V. = 13%
 T = 14%
 V = 55 M.P.H.
 D = 50%

FUNCTIONAL CLASSIFICATION- MAJOR COLLECTOR, SUPPLEMENTARY

MISSOURI HIGHWAYS AND TRANSPORTATION COMMISSION PLANS FOR PROPOSED STATE HIGHWAY DOUGLAS COUNTY

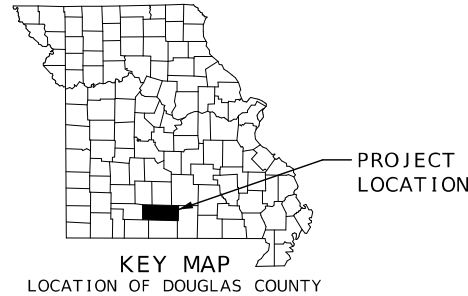

INDEX OF SHEETS

DESCRIPTION	SHEET NUMBER
TITLE SHEET	1
TYPICAL SECTIONS (TS) (1 SHEET)--	2
QUANTITIES (QU) (2 SHEETS)-----	3
SPECIAL SHEETS (SS)-----	4-5

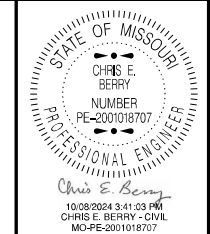

DATE PREPARED
10/4/2024
 ROUTE STATE
95 MO
 DISTRICT SHEET NO.
SE 1
 COUNTY
DOUGLAS
 JOB NO.
JSE0020
 CONTRACT ID.
 PROJECT NO.
 BRIDGE NO.

**CONVENTIONAL SYMBOLS
 (USED IN PLANS)**

	EXISTING	NEW
BUILDINGS AND STRUCTURES		
GUARD RAIL		
GUARD CABLE		
CONCRETE RIGHT-OF-WAY MARKER		
STEEL RIGHT-OF-WAY MARKER		
LOCATION SURVEY MARKER		
UTILITIES		
FIBER OPTICS	-FO-	-FO-
OVERHEAD CABLE TV	-OTV-	-OTV-
UNDERGROUND CABLE TV	-UTV-	-UTV-
OVERHEAD TELEPHONE	-OT-	-OT-
UNDERGROUND TELEPHONE	-UT-	-UT-
OVERHEAD POWER	-OE-	-OE-
UNDERGROUND POWER	-UE-	-UE-
SANITARY SEWER	-S-	-S-
STORM SEWER	-SS-	-SS-
GAS	-G-	-G-
WATER	-W-	-W-
MANHOLE		
FIRE HYDRANT		
WATER VALVE		
WATER METER		
DROP INLET		
DITCH BLOCK		
GROUND MOUNTED SIGN		
LIGHT POLE		
H-FRAME POWER POLE		
TELEPHONE PEDESTAL		
FENCE		
CHAIN LINK		
WOVEN WIRE		
GATE POST		
BENCHMARK		

NOTE: DASHED OR OPEN SYMBOLS INDICATE EXISTING FEATURES

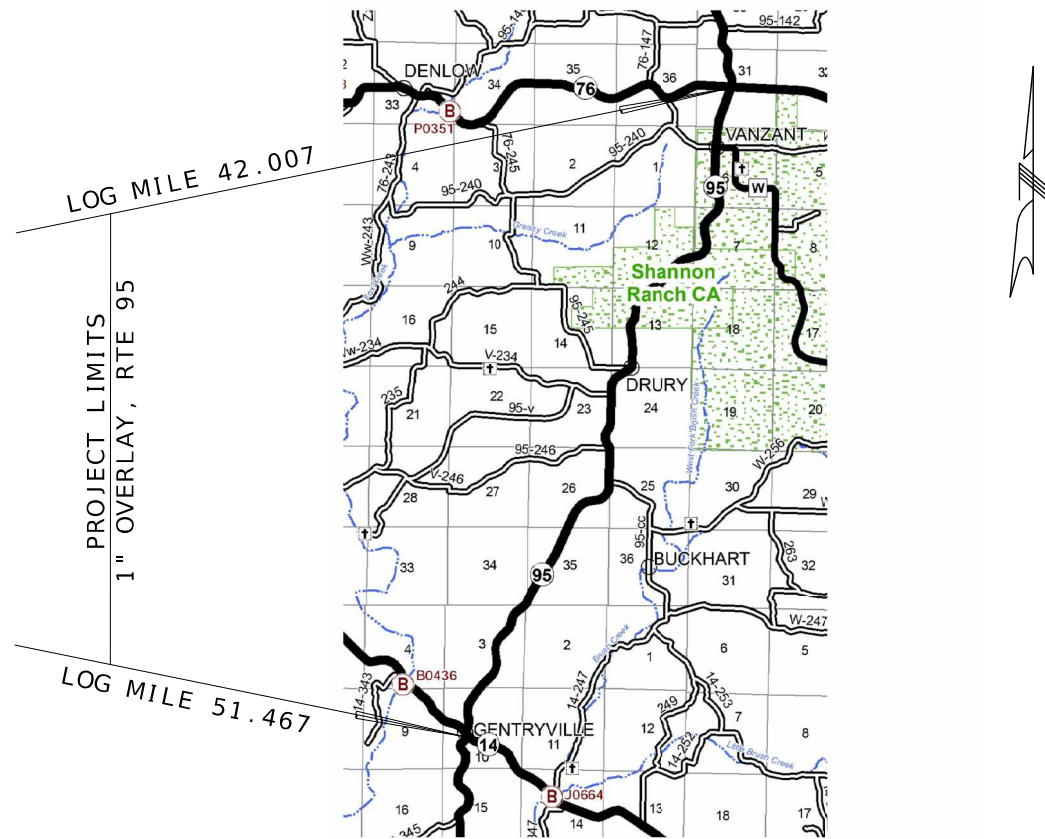

THE EXISTENCE AND APPROXIMATE LOCATION OF UTILITY FACILITIES KNOWN TO EXIST, AS SHOWN ON THE PLANS, ARE BASED ON THE BEST INFORMATION AVAILABLE TO THE COMMISSION AT THIS TIME. THIS INFORMATION IS PROVIDED BY THE COMMISSION "AS-IS" AND THE COMMISSION EXPRESSLY DISCLAIMS ANY REPRESENTATION OR WARRANTY AS TO THE COMPLETENESS, ACCURACY, OR SUITABILITY OF THE INFORMATION FOR ANY USE. RELIANCE UPON THIS INFORMATION IS DONE AT THE RISK AND PERIL OF THE USER, AND THE COMMISSION SHALL NOT BE LIABLE FOR ANY DAMAGES THAT MAY ARISE FROM ANY ERROR IN THE INFORMATION. IT IS, THEREFORE, THE RESPONSIBILITY OF THE CONTRACTOR TO VERIFY THE EXISTENCE, LOCATION AND STATUS OF ANY FACILITY. SUCH VERIFICATION INCLUDES DIRECT CONTACT WITH THE LISTED UTILITIES.

LENGTH OF PROJECT

BEGINNING OF PROJECT	LOG MILE	42.007
END OF PROJECT	LOG MILE	51.467
APPARENT LENGTH		49948.80 FEET
EQUATIONS AND EXCEPTIONS:		

TOTAL CORRECTIONS	0.00 FEET
NET LENGTH OF PROJECT	49948.80 FEET
STATE LENGTH	9.460 MILES
FOR INFORMATION ONLY ESTIMATED DISTURBED ACRES	0 ACRES

DESCRIPTION

DATE

MISSOURI HIGHWAYS AND TRANSPORTATION COMMISSION

105 WEST CAPITOL
JEFFERSON CITY, MO 65102
1-888-ASK-MODOT (1-888-275-6636)

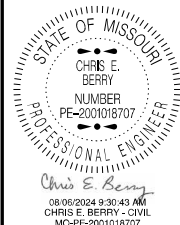

DATE PREPARED	
8/5/2024	
ROUTE	STATE
95	MO
DISTRICT	SHEET NO.
SE	2
COUNTY	
DOUGLAS	
JOB NO.	
JSE0020	
CONTRACT ID.	
PROJECT NO.	
BRIDGE NO.	

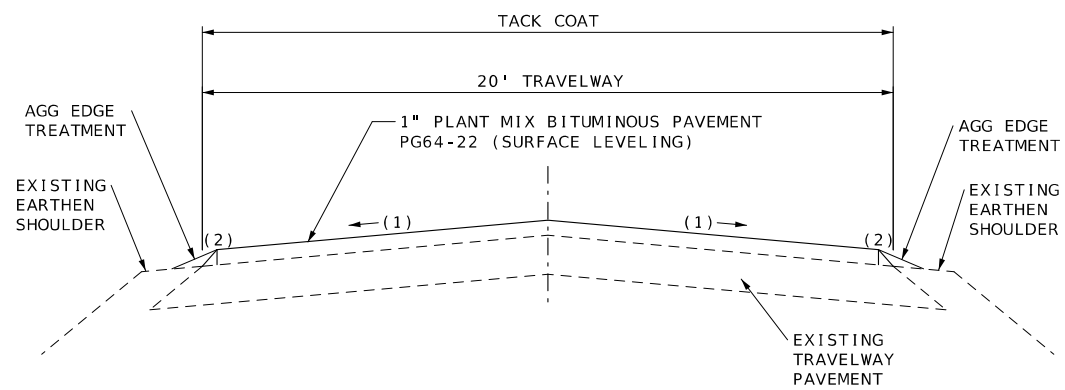

TYPICAL SECTION
ROUTE 95
LOG MILE 42.007 - 51.467

DATE	DESCRIPTION

BITUMINOUS PAVEMENT MIXTURE PG64-22 (SURFACE LEVELING)	2.0347 TON/YD ³
TACK COAT	0.08 GAL/YD ²

NOTES:
 - SURFACE PLACEMENT SHALL BE ONE PASS PER LANE.
 - REFER TO STANDARD PLAN 401.00C FOR SAFETY EDGE DETAIL.
 (1) MATCH EXISTING CROSS SLOPE. NO SUPERELEVATION CORRECTION.

LOG MILE LOCATIONS APPROXIMATE ADJUST AS DIRECTED BY ENGINEER TO FIT FIELD CONDITIONS.

TYPICAL SECTION SHEET
SHEET 1 OF 1

DRAWING NOT TO SCALE

MISSOURI HIGHWAYS AND TRANSPORTATION
COMMISSION
 105 WEST CAPITOL
JEFFERSON CITY, MO 65102
1-888-ASK-MODOT (1-888-275-6636)

PAVEMENT AND TACK									
LOG MILE	LOG MILE	LOC	LENGTH (FT)	WIDTH (FT)	THICK (IN)	BITUMINOUS PAVEMENT PG 64-22 (SURFACE LEVELING) (2.0347 TON/CY) (TONS)	TACK (0.08 GAL/SY) (GAL)	2390 REMARKS	
42.007	51.467	RT/LT	49949	20	1	6273.54	8879.9	ROUTE 95 TRAVELWAY - PROJECT LIMITS	
42.759	-	LT	VAR	70	1	20.10	28.5	STATE ROUTE W [3200 SF TOTAL AREA]	
VARIOUS	-	LT/RT	VAR	10	1	15.01	21.3	PAVED CITY / COUNTY ROADS [2 @ AVG LENGTH = 120']	
VARIOUS	-	LT/RT	VAR	10	3	30.15	14.3	NON-PAVED CITY / COUNTY ROADS [3 @ AVG LENGTH = 80']	
VARIOUS	-	LT/RT	VAR	2	1	0.51	0.8	PAVED PRIVATE / COMM ENTRANCES [1 @ AVG LENGTH = 40']	
VARIOUS	-	LT/RT	VAR	2	1	5.53	7.9	NON-PAVED PRIVATE / COMM ENTRANCES W/ APRON [11 @ AVG LENGTH = 40']	
42.007	51.467	LT/RT	49949	-	-	125.47	177.6	SAFETY EDGE [2% OF MAINLINE TONNAGE]	
42.007	51.467	LT/RT	49949	-	-	1419.01	-	RUTTING & IRREGULARITIES [150 TONS/MILE]	
						TOTAL	7889.32	9130.3	
						USE	7889.4	9131	

LOG MILES ARE APPROXIMATE.

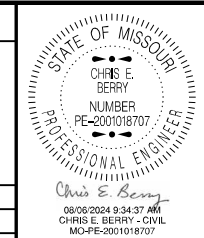

DATE PREPARED 7/10/2024	
ROUTE 95	STATE MO
DISTRICT SE	SHEET NO. 3
COUNTY DOUGLAS	
JOB NO. JSE0020	
CONTRACT ID.	
PROJECT NO.	
BRIDGE NO.	

COLDMILLING							
LOG MILE	LOG MILE	LOC	MODIFIED COLDMILLING				REMARKS
			AREA (SF)	LENGTH (FT)	WIDTH (FT)	DEPTH TRANSITION (SY)	
42.007	42.017	LT/RT		50	20	111.1	ROUTE 95 TRAVELWAY - BEGIN PROJECT
51.457	51.467	LT/RT		50	20	111.1	ROUTE 95 TRAVELWAY - END PROJECT
42.759	-	RT		20	25	55.6	STATE ROUTE INTERSECTION - ROUTE W
VARIOUS	-	LT/RT		240	10	266.7	PAVED CITY / COUNTY ROAD INTERSECTIONS [2 @ AVG LENGTH = 120']
VARIOUS	-	LT/RT		40	2	8.9	PAVED PRIVATE / COMM ENTRANCES [1 @ WIDTH = 40']
						TOTAL	553.4
						USE	554

LOG MILES ARE APPROXIMATE.

GRAVEL A OR CRUSHED STONE B / AGGREGATE EDGE TREATMENT						
LOG MILE	LOG MILE	LOC	LENGTH (MI)	GRAVEL A OR CRUSHED STONE B (TONS)	PERM AGG EDGE TREATMENT (TONS)	REMARKS
42.007	51.467	RT	9.46	-	851.4	AGGREGATE EDGE TREATMENT - ROUTE 95 TRAVELWAY PROJECT LIMITS [90 TONS/MI]
42.007	51.467	LT	9.46	-	851.4	AGGREGATE EDGE TREATMENT - ROUTE 95 TRAVELWAY PROJECT LIMITS [90 TONS/MI]
VARIOUS	-	RT/LT	-	6.0	-	NON-PAVED CITY / COUNTY ROADS [3 @ 2 TONS EA]
VARIOUS	-	RT/LT	-	11.0	-	NON-PAVED PRIVATE / COMM ENTRANCES W/ APRON [11 @ 1 TON EA]
VARIOUS	-	RT/LT	-	63.0	-	NON-PAVED PRIVATE / COMM ENTRANCES W/O APRON [52 @ 1 TON EA]
			TOTAL	80.0	1702.8	
			USE	80	1703	

LOG MILES ARE APPROXIMATE.

MOBILIZATION
1 LUMP SUM

PERMANENT PAVEMENT MARKING					
LOG MILE	LOG MILE	LENGTH (FT)	WATERBORNE TYPE P BEADS 4" WHITE (LF)	WATERBORNE TYPE P BEADS 4" YELLOW (LF)	REMARKS
42.007	51.467	49948.8	99897.6	99561.3	FINAL PAVEMENT MARKING
			TOTAL	99897.6	99561.3
			USE	99898	99562

LOG MILES ARE APPROXIMATE.
SEE PAVEMENT MARKING LOG JSP.

DESCRIPTION	DATE

MISSOURI HIGHWAYS AND TRANSPORTATION COMMISSION

105 WEST CAPITOL JEFFERSON CITY, MO 65102
1-888-ASK-MODOT (1-888-275-6636)

**DETAIL 1
BEGIN PROJECT**

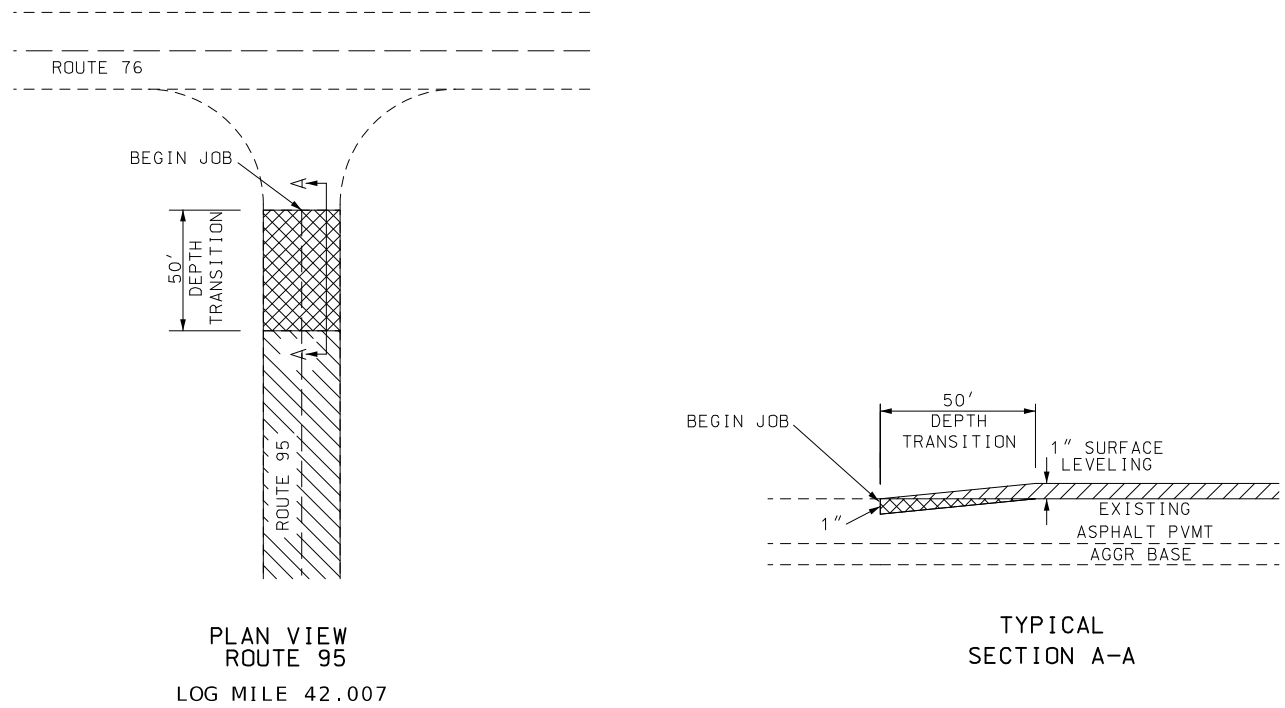

**DETAIL 2
END PROJECT**

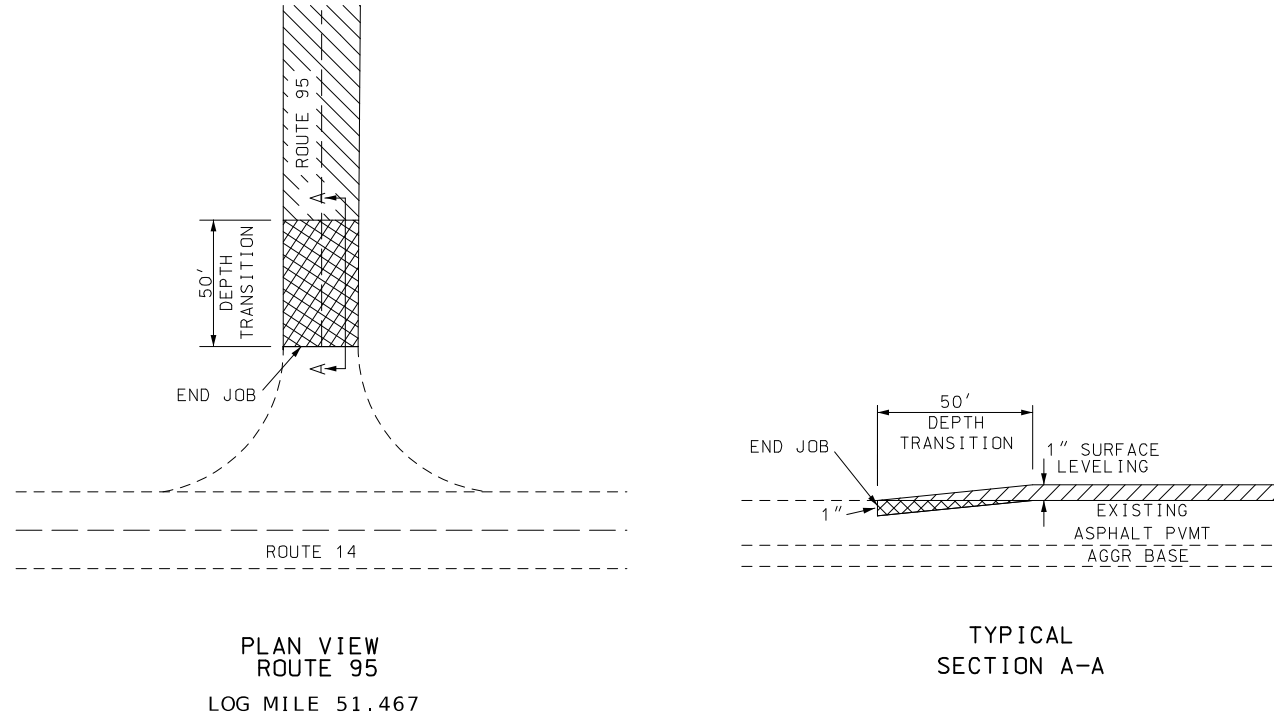

**DETAIL 3
STATE ROUTE INTERSECTION**

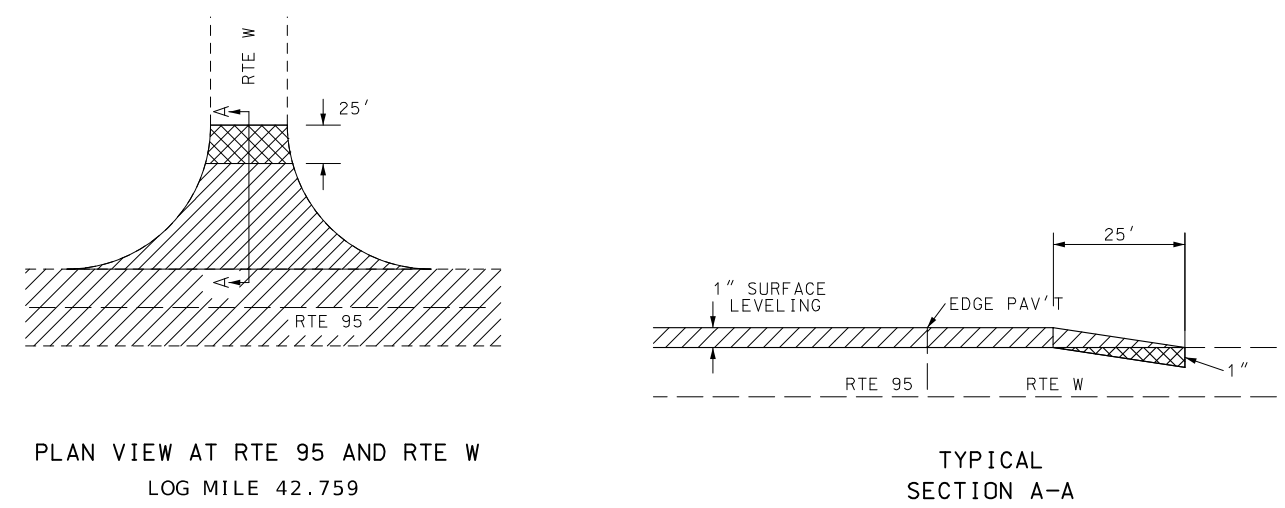

- OVERLAY
- MODIFIED COLDMILLING

LOG MILE LOCATIONS APPROXIMATE. ADJUST AS DIRECTED BY ENGINEER TO FIT FIELD CONDITIONS.

SPECIAL SHEET
SHEET 1 OF 2

DRAWING NOT TO SCALE

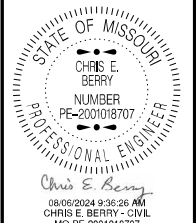

DATE PREPARED 8/6/2024	
ROUTE 95	STATE MO
DISTRICT SE	SHEET NO. 4
COUNTY DOUGLAS	
JOB NO. JSE0020	
CONTRACT ID.	
PROJECT NO.	
BRIDGE NO.	

DATE	DESCRIPTION

MISSOURI HIGHWAYS AND TRANSPORTATION COMMISSION

105 WEST CAPITOL
JEFFERSON CITY, MO 65102
1-888-ASK-MODOT (1-888-275-6636)

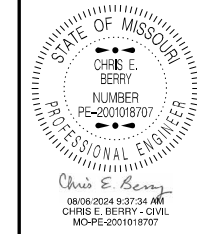

DATE PREPARED
7/11/2024

ROUTE **95** STATE **MO**

DISTRICT **SE** SHEET NO. **5**

COUNTY
DOUGLAS

JOB NO.
JSE0020

CONTRACT ID.

PROJECT NO.

BRIDGE NO.

DETAIL 1
PAVED ENTRANCES

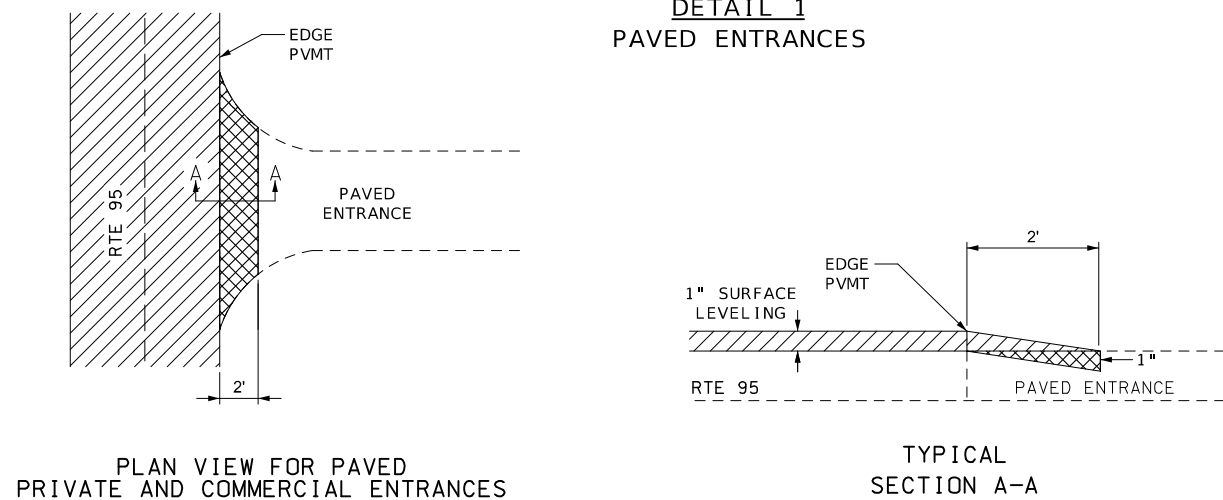

DETAIL 2
PAVED INTERSECTIONS

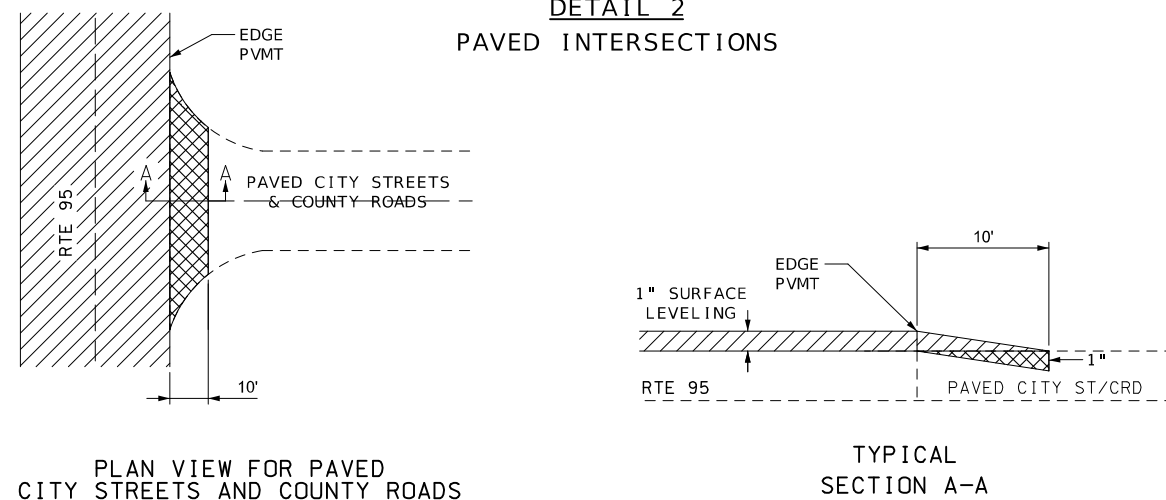

DETAIL 3
NON-PAVED ENTRANCES

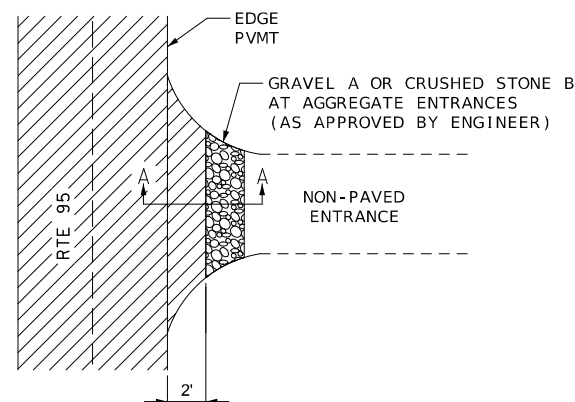

DETAIL 3
NON-PAVED ENTRANCES

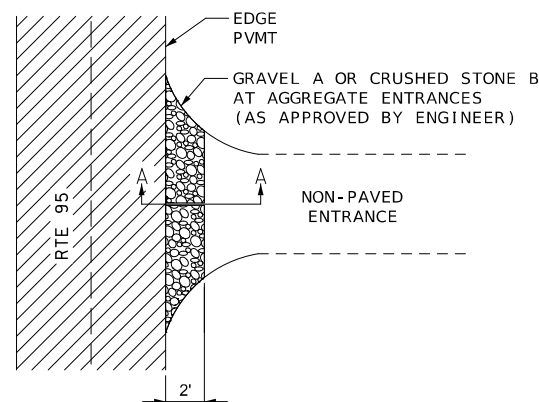

DETAIL 4
NON-PAVED INTERSECTIONS

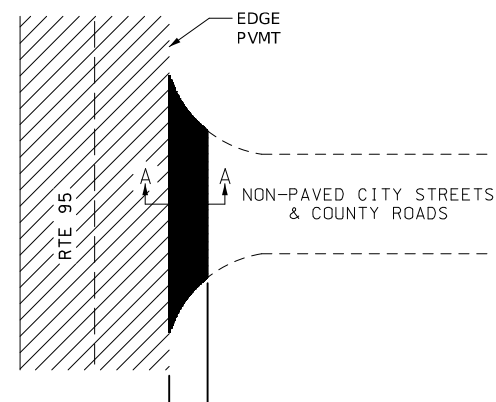

PLAN VIEW FOR NON-PAVED PRIVATE AND COMMERCIAL ENTRANCES WITH EXISTING APRON

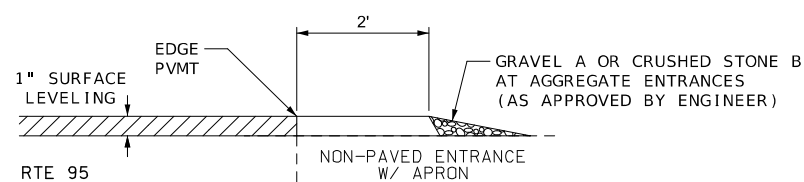

PLAN VIEW FOR NON-PAVED PRIVATE AND COMMERCIAL ENTRANCES WITHOUT EXISTING APRON

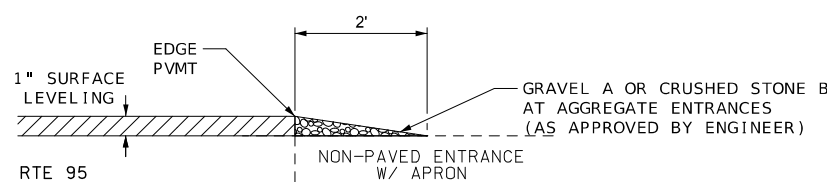

PLAN VIEW FOR NON-PAVED CITY STREETS AND COUNTY ROADS

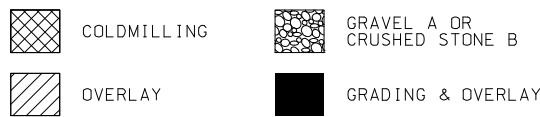
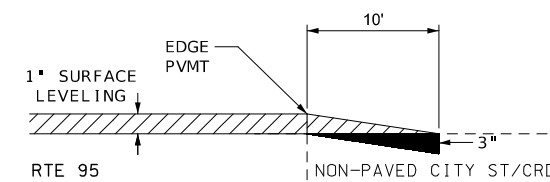

NOTES:

- ALL GRADING NECESSARY FOR THE PROPER CONSTRUCTION OF HOT MIX AND AGGREGATE APRONS SHALL BE CONSIDERED INCIDENTAL WORK AND AT NO DIRECT PAY.
- THE WIDTH OF ALL HOT MIX AND AGGREGATE APRONS MAY BE ADJUSTED BY THE ENGINEER AS NECESSARY TO OBTAIN SUITABLE TRANSITIONS.

LOG MILE LOCATIONS APPROXIMATE. ADJUST AS DIRECTED BY ENGINEER TO FIT FIELD CONDITIONS.

SPECIAL SHEET
SHEET 2 OF 2
DRAWING NOT TO SCALE

DESCRIPTION	DATE

MISSOURI HIGHWAYS AND TRANSPORTATION COMMISSION

MoDOT

105 WEST CAPITOL
JEFFERSON CITY, MO 65102
1-888-ASK-MODOT (1-888-275-6636)