

DESIGN DESIGNATION

A.A.D.T. - 2023 = 25,882
 T = 35.1%
 V = 70 M.P.H.
 D = 47.8% (N) / 52.2% (S)

FUNCTIONAL CLASSIFICATION - INTERSTATE

NO RIGHT-OF-WAY ACQUISITION

MISSOURI HIGHWAYS AND TRANSPORTATION COMMISSION PLANS FOR PROPOSED STATE HIGHWAY ANDREW COUNTY

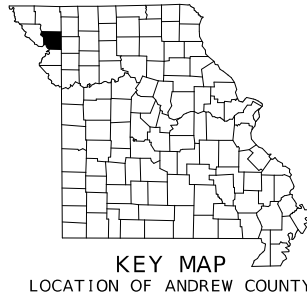

KEY MAP
 LOCATION OF ANDREW COUNTY

INDEX OF SHEETS

DESCRIPTION	SHEET NUMBER
TITLE SHEET	1
TYPICAL SECTIONS (TS) (3 SHEETS)	2
QUANTITIES (QU) (3 SHEETS)	3
PLAN-PROFILE (PP)	4
SPECIAL SHEETS (SS)	5-8
TRAFFIC CONTROL SHEETS (TC)	9-20
EROSION CONTROL SHEETS (EC)	21
BRIDGE DRAWINGS (B)	
A12902	1-8
A12903	1-8



DATE PREPARED
 10/7/2024
 ROUTE 1-29 STATE MO
 DISTRICT NW SHEET NO. 1
 COUNTY ANDREW
 JOB NO. J113262
 CONTRACT ID.
 PROJECT NO.
 BRIDGE NO.

CONVENTIONAL SYMBOLS (USED IN PLANS)

	EXISTING	NEW
BUILDINGS AND STRUCTURES	[Symbol]	[Symbol]
GUARD RAIL	[Symbol]	[Symbol]
GUARD CABLE	[Symbol]	[Symbol]
CONCRETE RIGHT-OF-WAY MARKER	[Symbol]	[Symbol]
STEEL RIGHT-OF-WAY MARKER	[Symbol]	[Symbol]
LOCATION SURVEY MARKER	[Symbol]	[Symbol]
UTILITIES		
FIBER OPTICS	-FO-	-FO-
OVERHEAD CABLE TV	-OTV-	-OTV-
UNDERGROUND CABLE TV	-UTV-	-UTV-
OVERHEAD TELEPHONE	-OT-	-OT-
UNDERGROUND TELEPHONE	-UT-	-UT-
OVERHEAD POWER	-OE-	-OE-
UNDERGROUND POWER	-UE-	-UE-
SANITARY SEWER	-S-	-S-
STORM SEWER	-SS-	-SS-
GAS	-G-	-G-
WATER	-W-	-W-
MANHOLE	[Symbol]	[Symbol]
FIRE HYDRANT	[Symbol]	[Symbol]
WATER VALVE	[Symbol]	[Symbol]
WATER METER	[Symbol]	[Symbol]
DROP INLET	[Symbol]	[Symbol]
DITCH BLOCK	[Symbol]	[Symbol]
GROUND MOUNTED SIGN	[Symbol]	[Symbol]
LIGHT POLE	[Symbol]	[Symbol]
H-FRAME POWER POLE	[Symbol]	[Symbol]
TELEPHONE PEDESTAL	[Symbol]	[Symbol]
FENCE		
CHAIN LINK	[Symbol]	[Symbol]
WOVEN WIRE	[Symbol]	[Symbol]
GATE POST	[Symbol]	[Symbol]
BENCHMARK	[Symbol]	[Symbol]

NOTE: DASHED OR OPEN SYMBOLS INDICATE EXISTING FEATURES

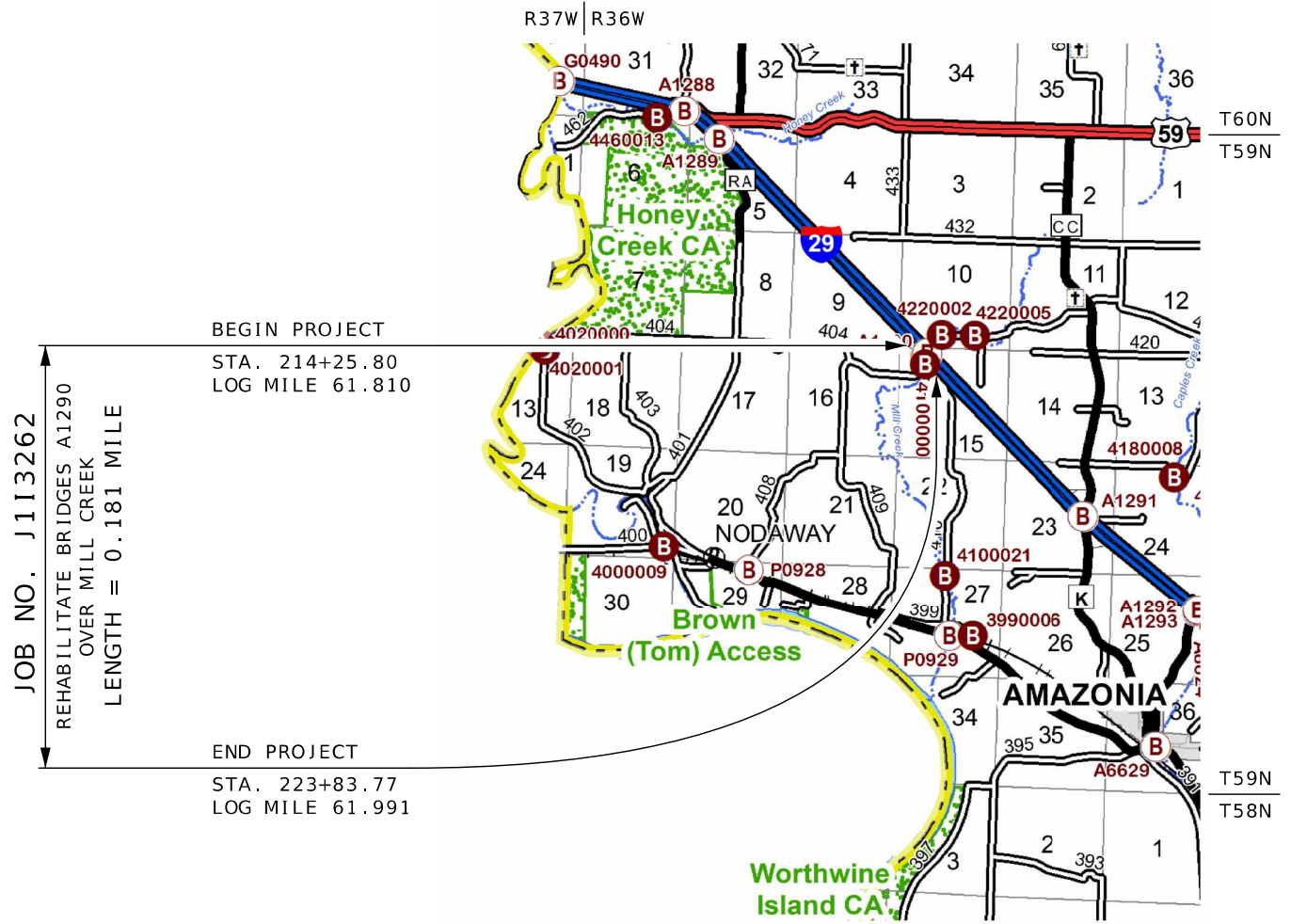

THE EXISTENCE AND APPROXIMATE LOCATION OF UTILITY FACILITIES KNOWN TO EXIST, AS SHOWN ON THE PLANS, ARE BASED ON THE BEST INFORMATION AVAILABLE TO THE COMMISSION AT THIS TIME. THIS INFORMATION IS PROVIDED BY THE COMMISSION "AS-IS" AND THE COMMISSION EXPRESSLY DISCLAIMS ANY REPRESENTATION OR WARRANTY AS TO THE COMPLETENESS, ACCURACY, OR SUITABILITY OF THE INFORMATION FOR ANY USE. RELIANCE UPON THIS INFORMATION IS DONE AT THE RISK AND PERIL OF THE USER, AND THE COMMISSION SHALL NOT BE LIABLE FOR ANY DAMAGES THAT MAY ARISE FROM ANY ERROR IN THE INFORMATION. IT IS, THEREFORE, THE RESPONSIBILITY OF THE CONTRACTOR TO VERIFY THE EXISTENCE, LOCATION AND STATUS OF ANY FACILITY. SUCH VERIFICATION INCLUDES DIRECT CONTACT WITH THE LISTED UTILITIES.

LENGTH OF PROJECT

BEGINNING OF PROJECT	STA. 214+25.80
END OF PROJECT	STA. 223+83.77
APPARENT LENGTH	957.97 FEET
EQUATIONS AND EXCEPTIONS:	
TOTAL CORRECTIONS	0.00 FEET
NET LENGTH OF PROJECT	957.97 FEET
STATE LENGTH	0.181 MILES
FOR INFORMATION ONLY ESTIMATED DISTURBED ACRES	<1 ACRE

DESCRIPTION

DATE

MISSOURI HIGHWAYS AND TRANSPORTATION COMMISSION

MoDOT

105 WEST CAPITOL
 JEFFERSON CITY, MO 65102
 1-888-ASK-MODOT (1-888-275-6636)

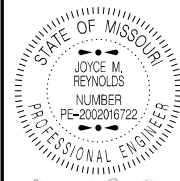

DATE PREPARED
10/3/2024

ROUTE STATE
I-29 MO

DISTRICT SHEET NO.
NW 2

COUNTY
ANDREW

JOB NO.
J113262

CONTRACT ID.

PROJECT NO.

BRIDGE NO.

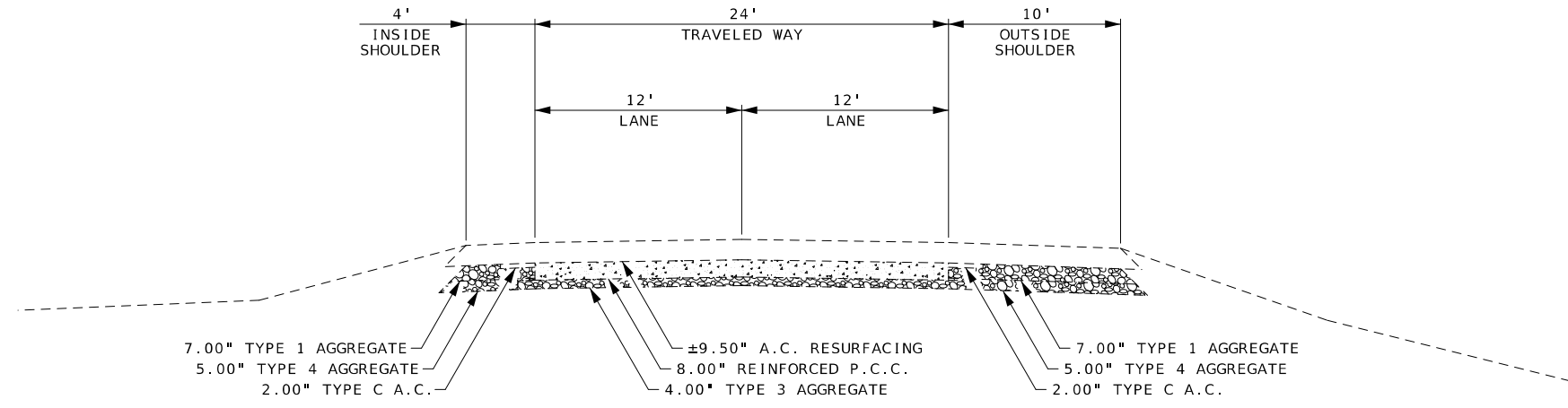

HALF-SECTION ON TANGENT
EXISTING TYPICAL SECTION ROUTE I-29
STA. 214+25.80 TO STA. 223+83.77

ESTIMATE FACTORS *		
ITEM	DESCRIPTION	FACTOR
403-01.05	ASPHALTIC CONCRETE MIXTURE PG76-22 (SP125C MIX)	1.99 TONS/CU. YD.
407-10.05	TACK COAT - ON EXISTING MILLED ASPHALT	0.10 GAL./SQ. YD.

* FOR INFORMATION PURPOSES ONLY

NOT TO SCALE

TYPICAL SECTIONS
SHEET 1 OF 3

DATE	DESCRIPTION

MISSOURI HIGHWAYS AND TRANSPORTATION COMMISSION

105 WEST CAPITOL
JEFFERSON CITY, MO 65102
1-888-ASK-MODOT (1-888-273-6636)

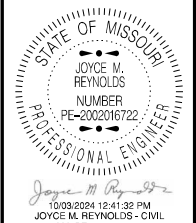

DATE PREPARED
10/3/2024

ROUTE STATE
I - 29 MO

DISTRICT SHEET NO.
NW 2

COUNTY
ANDREW

JOB NO.
J113262

CONTRACT ID.

PROJECT NO.

BRIDGE NO.

DESCRIPTION

DATE

MISSOURI HIGHWAYS AND TRANSPORTATION
COMMISSION

105 WEST CAPITOL
JEFFERSON CITY, MO 65102
1-888-ASK-MODOT (1-888-275-6636)

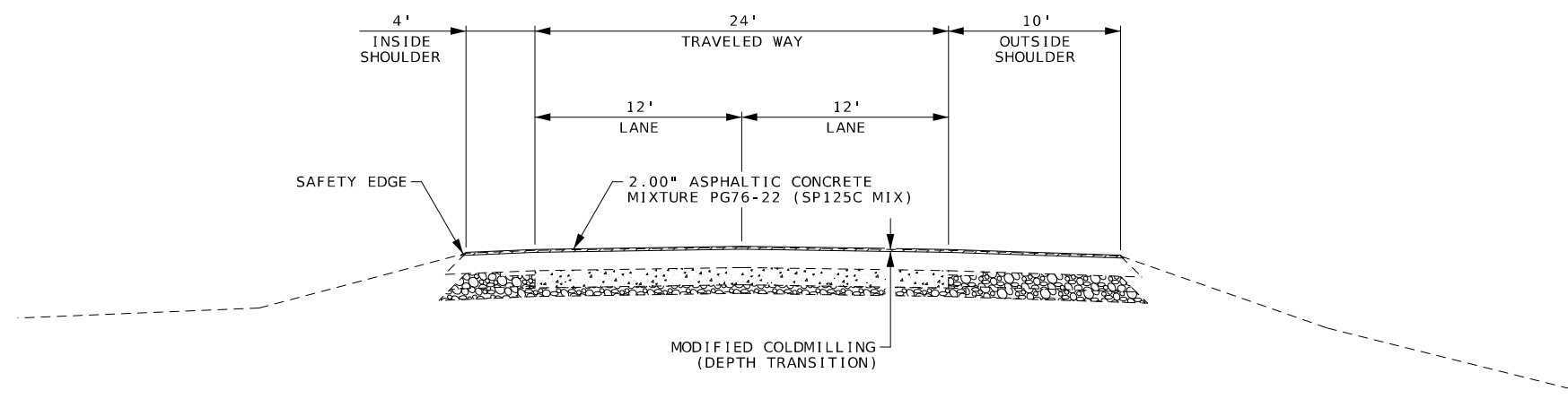

HALF-SECTION ON TANGENT
PROPOSED TYPICAL SECTION ROUTE I-29
N.B.L. STA. 216+85.22 TO STA. 217+25.22
STA. 220+51.77 TO STA. 220+91.77
S.B.L. STA. 217+17.80 TO STA. 217+57.80
STA. 220+84.35 TO STA. 221+24.35

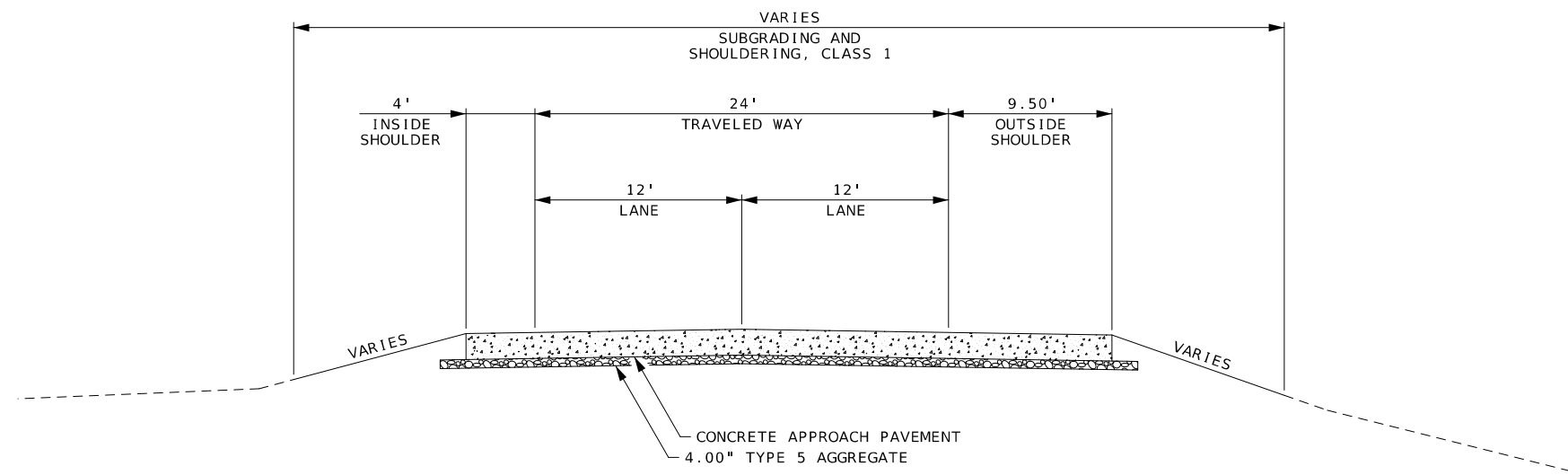

HALF-SECTION ON TANGENT
PROPOSED TYPICAL SECTION ROUTE I-29
N.B.L. STA. 217+25.22 TO STA. 217+47.05
STA. 220+29.95 TO STA. 220+51.77
S.B.L. STA. 217+57.80 TO STA. 217+79.62
STA. 220+62.52 TO STA. 221+84.35

NOTE: SEE BRIDGE PLANS FOR BRIDGE APPROACH
SLAB AND BRIDGE REHABILITATION DETAILS.

NOT TO SCALE

TYPICAL SECTIONS
SHEET 2 OF 3

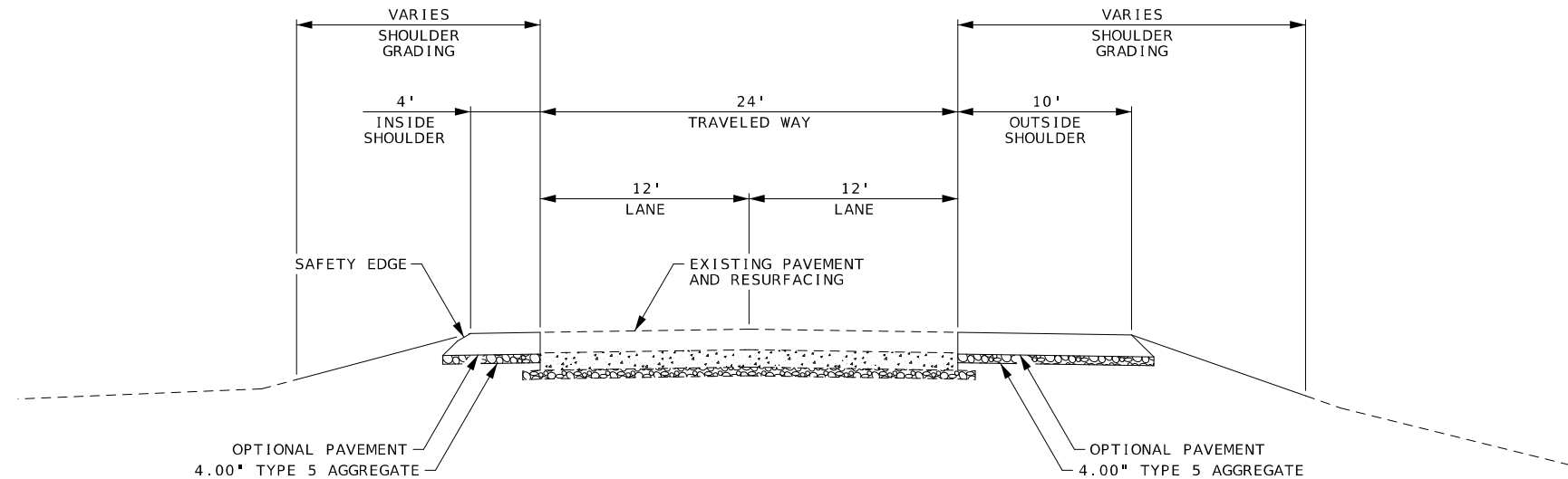

HALF-SECTION ON TANGENT
PROPOSED TYPICAL SECTION SHOULDER RECONSTRUCTION
 (CONSTRUCT PRIOR TO THE SHIFTING OF TRAFFIC ONTO THE SHOULDER)

N.B.L. OUTSIDE SHOULDER	STA. 214+95.22 TO STA. 217+40.22
	STA. 220+36.77 TO STA. 224+16.77
N.B.L. INSIDE SHOULDER	STA. 215+25.22 TO STA. 217+40.22
	STA. 220+36.77 TO STA. 223+86.77
S.B.L. OUTSIDE SHOULDER	STA. 213+92.80 TO STA. 217+72.80
	STA. 220+69.35 TO STA. 223+14.35
S.B.L. INSIDE SHOULDER	STA. 214+22.80 TO STA. 217+72.80
	STA. 220+69.35 TO STA. 222+84.35

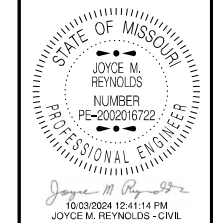
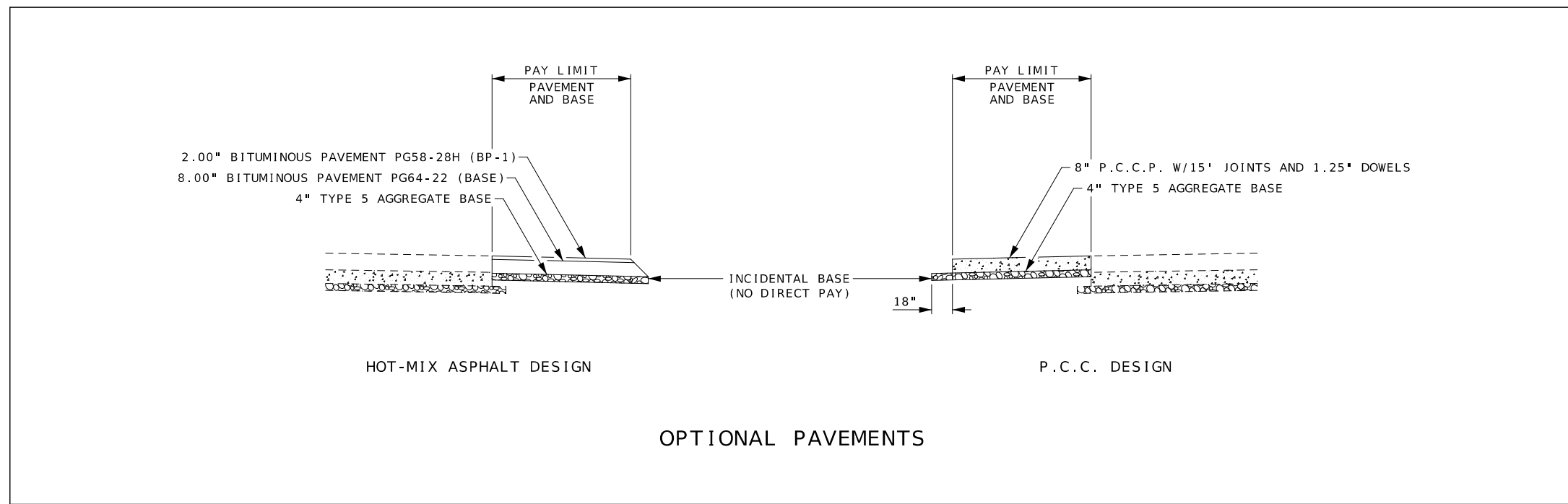

DATE PREPARED
10/3/2024

ROUTE I - 29	STATE MO
DISTRICT NW	SHEET NO. 2

COUNTY
ANDREW

JOB NO.
J113262

CONTRACT ID.

PROJECT NO.

BRIDGE NO.

DESCRIPTION	DATE

MISSOURI HIGHWAYS AND TRANSPORTATION COMMISSION

105 WEST CAPITOL
 JEFFERSON CITY, MO 65102
 1-888-ASK-MODOT (1-888-275-6636)

NOT TO SCALE

TYPICAL SECTIONS
 SHEET 3 OF 3

Table with columns: SIGN, SIZE, AREA, QTY, TOTAL AREA, QTY RELOC, TOTAL RELOC, SIGN NUM., DESCRIPTION. Includes sections for WARNING SIGNS, REGULATORY SIGNS, and MISCELLANEOUS SIGNS.

Table with columns: SIGN, SIZE, AREA, QTY, TOTAL, RELOC, SIGN NUM., DESCRIPTION. Includes sections for GUIDE SIGNS and CONSTRUCTION SIGNS.

Table with columns: ITEM NUMBER, TOTAL QTY, DESCRIPTION. Lists various traffic control items and their quantities.

616-99.01 - MISC. LUMP SUM TEMPORARY TRAFFIC CONTROL
1 LUMP SUM

NOTES: ALL TEMPORARY TRAFFIC CONTROL ITEMS ARE INCLUDED IN PAY ITEM 616-99.01, MISC. LUMP SUM TEMPORARY TRAFFIC CONTROL, UNLESS OTHERWISE NOTED. THE QUANTITIES SHOWN ARE AN ESTIMATE ONLY AND ARE SUBJECT TO CHANGE BASED ON FIELD CONDITIONS.

Professional Engineer seal for Joyce M. Reynolds, Missouri Highways and Transportation Commission logo, and project details including route 1-29, MO, and job number J113262.

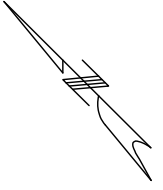

SEE SHEETS 5-6 FOR PAVEMENT AND GUARDRAIL DETAILS.
SEE SHEETS 7-8 FOR SHOULDER RECONSTRUCTION DETAILS.

KEY TO SYMBOLS

OBLITERATION

STA. 217+68.05 N.B.L. ROUTE I-29
U.I.P. AND REHABILITATE BRIDGE A12902
46'-69'-69'-55' CONTINUOUS COMPOSITE WIDE FLANGE BEAM SPANS
37'-6" ROADWAY, 20° R.A.

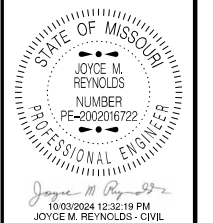

DATE PREPARED
10/3/2024

ROUTE	STATE
I-29	MO
DISTRICT	SHEET NO.
NW	4

COUNTY
ANDREW

JOB NO.
J113262

CONTRACT ID.

PROJECT NO.

BRIDGE NO.

215 BEGIN PROJECT STA. 214+25.80 ☉ MEDIAN ROUTE I-29

220

225

* CRASHWORTHY END TERMINALS TO BE REMOVED AND RESET, SEE SHEETS 5-6 FOR DETAILS.

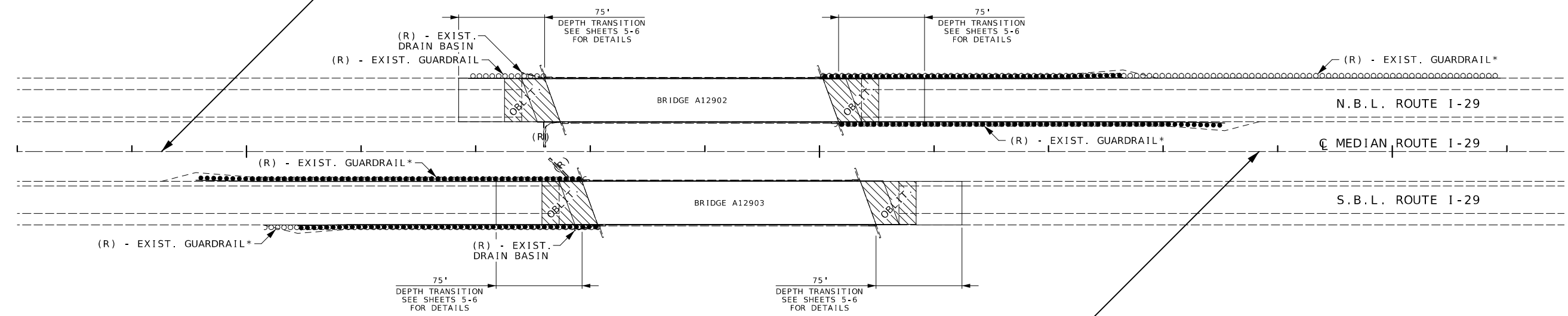

END PROJECT STA. 223+83.77 ☉ MEDIAN ROUTE I-29

LIMITS OF SUBGRADE COMPACTION AND SUBGRADING AND SHOULDERING, CLASS 1

STATION TO	STATION	LOCATION
217+25.22	217+74.05	N.B.L. ROUTE I-29
217+57.80	218+06.63	S.B.L. ROUTE I-29
220+02.94	220+51.77	N.B.L. ROUTE I-29
220+35.52	220+84.35	S.B.L. ROUTE I-29

ANY ITEMS OF WORK BEYOND THE PROJECT LIMITS ARE INCIDENTAL TO AND A PART OF THE CONSTRUCTION OF THIS PROJECT.

UTILITIES

ANDREW COUNTY PWS# 1 LUMEN
201 SOUTH 71 HIGHWAY 100 CENTURYLINK DRIVE
SAVANNAH, MO 64485 MONROE, LA 71203
(816) 324-6266 (877) 366-8344

BRIGHTSPEED
1120 SOUTH TRYON STREET
CHARLOTTE, NC 28203
(833) 363-2360

STA. 217+98.62 S.B.L. ROUTE I-29
U.I.P. AND REHABILITATE BRIDGE A12903
46'-69'-69'-55' CONTINUOUS COMPOSITE WIDE FLANGE BEAM SPANS
37'-6" ROADWAY, 20° R.A.

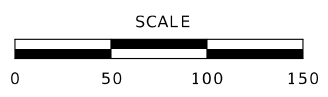

DATE	DESCRIPTION

MISSOURI HIGHWAYS AND TRANSPORTATION COMMISSION

105 WEST CAPITOL JEFFERSON CITY, MO 65102
1-888-ASK-MODOT (1-888-275-6636)

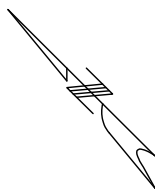

214

215

216

217

218

219

NOTE: STATIONING GIVEN FOR THE SKEWED PORTIONS OF THE CONCRETE APPROACH PAVEMENT AND BRIDGE APPROACH SLAB IS AT THE CENTERLINE OF THE STRUCTURE.

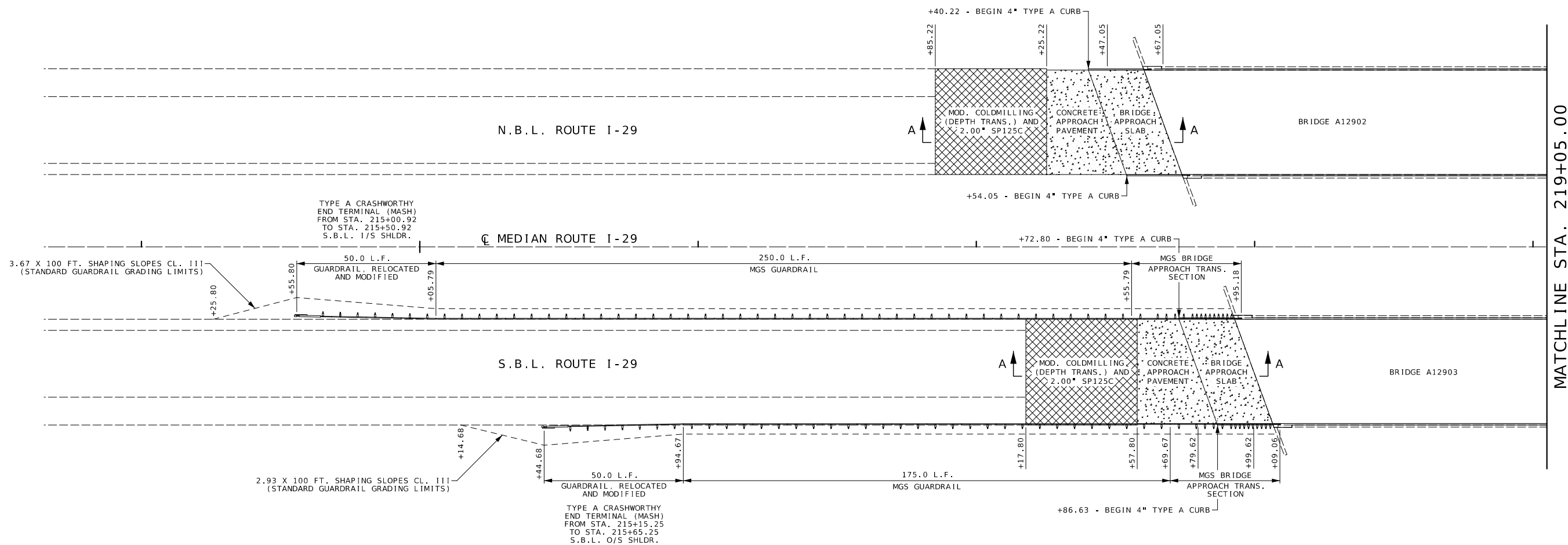

STA. 214+55.80 TO STA. 217+95.18
 S.B.L. ROUTE 1-29, INSIDE SHOULDER
 BUILD 50.0 L.F. GUARDRAIL, RELOCATED AND MODIFIED
 (TYPE A CRASHWORTHY END TERMINAL (MASH))
 250.0 L.F. MGS GUARDRAIL
 1-MGS BRIDGE APPROACH TRANSITION SECTION (EXTENDED CURB)

STA. 215+44.68 TO STA. 218+09.06
 S.B.L. ROUTE 1-29, OUTSIDE SHOULDER
 BUILD 50.0 L.F. GUARDRAIL, RELOCATED AND MODIFIED
 (TYPE A CRASHWORTHY END TERMINAL (MASH))
 175.0 L.F. MGS GUARDRAIL
 1-MGS BRIDGE APPROACH TRANSITION SECTION (EXTENDED CURB)

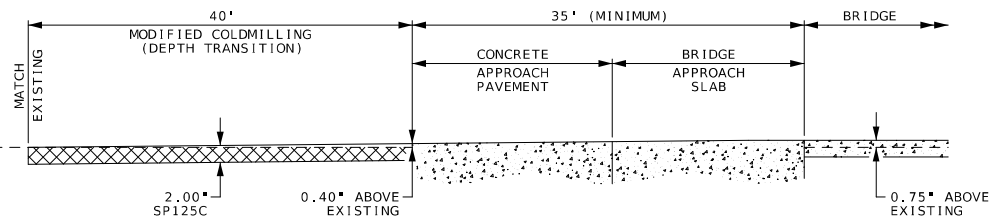

SECTION A-A
NOT TO SCALE

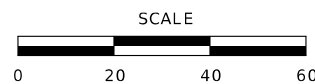

PAVEMENT AND GUARDRAIL
SPECIAL SHEET 1 OF 4

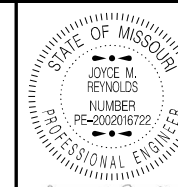

DATE PREPARED
10/3/2024

ROUTE
I-29

STATE
MO

DISTRICT
NW

SHEET NO.
5

COUNTY
ANDREW

JOB NO.
J113262

CONTRACT ID.

PROJECT NO.

BRIDGE NO.

DESCRIPTION

DATE

DATE

DATE

DATE

DATE

DATE

DATE

DATE

DATE

DATE

DATE

DATE

DATE

DATE

DATE

DATE

DATE

DATE

DATE

DATE

DATE

DATE

DATE

DATE

DATE

DATE

DATE

DATE

DATE

DATE

DATE

DATE

DATE

DATE

DATE

DATE

DATE

DATE

DATE

DATE

DATE

DATE

DATE

DATE

DATE

DATE

DATE

DATE

DATE

DATE

DATE

DATE

DATE

DATE

DATE

DATE

DATE

DATE

DATE

DATE

DATE

DATE

DATE

DATE

DATE

DATE

DATE

DATE

DATE

DATE

DATE

MISSOURI HIGHWAYS AND TRANSPORTATION
 COMMISSION

105 WEST CAPITOL
 JEFFERSON CITY, MO 65102
 1-888-ASK-MODOT (1-888-275-6636)

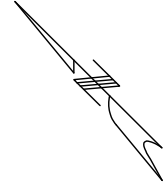

220

221

222

223

224

MATCHLINE STA. 219+05.00

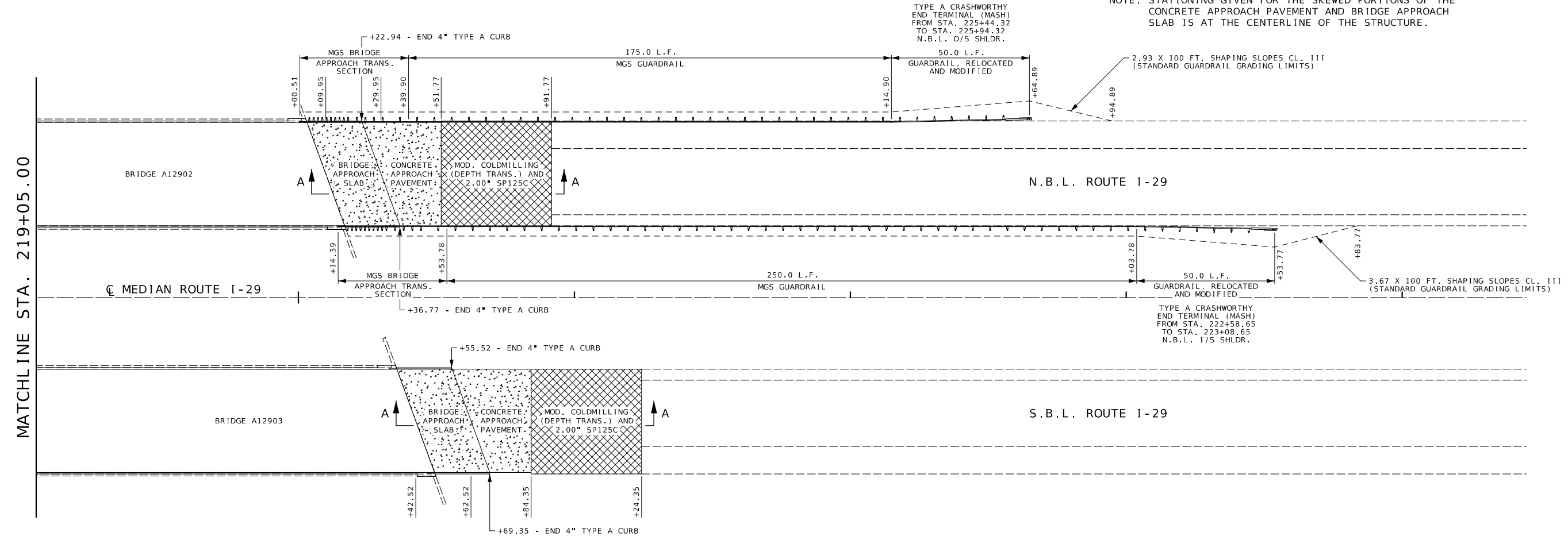

TYPE A CRASHWORTHY
END TERMINAL (MASH)
FROM STA. 225+44.32
TO STA. 225+94.32
N.B.L. O/S SHLDR.

NOTE: STATIONING GIVEN FOR THE SKEWED PORTIONS OF THE
CONCRETE APPROACH PAVEMENT AND BRIDGE APPROACH
SLAB IS AT THE CENTERLINE OF THE STRUCTURE.

2.93 X 100 FT. SHAPING SLOPES CL. III
(STANDARD GUARDRAIL GRADING LIMITS)

TYPE A CRASHWORTHY
END TERMINAL (MASH)
FROM STA. 222+58.65
TO STA. 223+08.65
N.B.L. I/S SHLDR.

3.67 X 100 FT. SHAPING SLOPES CL. III
(STANDARD GUARDRAIL GRADING LIMITS)

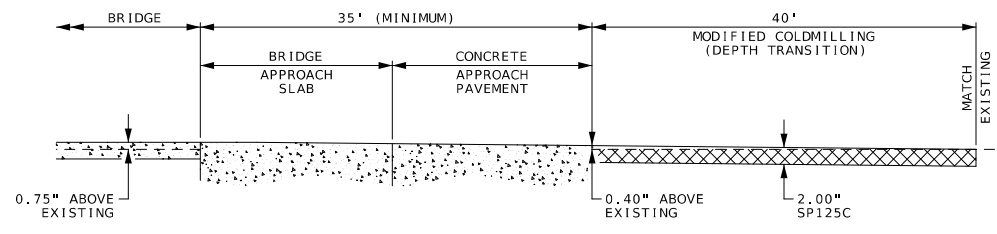

SECTION A-A
NOT TO SCALE

- STA. 220+00.51 TO STA. 222+64.89
N.B.L. ROUTE I-29, OUTSIDE SHOULDER
BUILD 1-MGS BRIDGE APPROACH TRANSITION SECTION (EXTENDED CURB)
175.0 L.F. MGS GUARDRAIL
50.0 L.F. GUARDRAIL, RELOCATED AND MODIFIED
(TYPE A CRASHWORTHY END TERMINAL (MASH))
- STA. 220+14.39 TO STA. 223+53.77
N.B.L. ROUTE I-29, INSIDE SHOULDER
BUILD 1-MGS BRIDGE APPROACH TRANSITION SECTION (EXTENDED CURB)
250.0 L.F. MGS GUARDRAIL
50.0 L.F. GUARDRAIL, RELOCATED AND MODIFIED
(TYPE A CRASHWORTHY END TERMINAL (MASH))

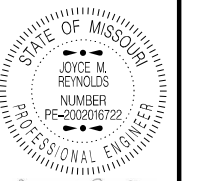
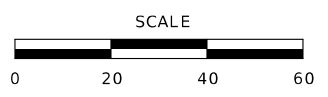

DATE PREPARED
10/3/2024

ROUTE STATE
I - 29 MO
DISTRICT SHEET NO.
NW 6

COUNTY
ANDREW
JOB NO.
J113262
CONTRACT ID.

PROJECT NO.
BRIDGE NO.

DESCRIPTION	DATE

MISSOURI HIGHWAYS AND TRANSPORTATION
COMMISSION

105 WEST CAPITOL
JEFFERSON CITY, MO 65102
1-888-ASK-MODOT (1-888-275-6636)

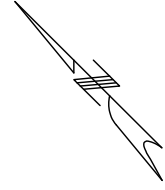

214

215

216

217

218

219

N.B.L. ROUTE 1-29

☉ MEDIAN ROUTE 1-29

S.B.L. ROUTE 1-29

245.00'
BUILD 2.45 X 100 FT. SHOULDER GRADING
272.2 S.Y. TYPE 5 AGGREGATE FOR BASE
272.22 S.Y. OPTIONAL PAVEMENT

215.00'
BUILD 2.15 X 100 FT. SHOULDER GRADING
95.6 S.Y. TYPE 5 AGGREGATE FOR BASE
95.56 S.Y. OPTIONAL PAVEMENT

350.00'
BUILD 3.50 X 100 FT. SHOULDER GRADING
155.6 S.Y. TYPE 5 AGGREGATE FOR BASE
155.56 S.Y. OPTIONAL PAVEMENT

380.00'
BUILD 3.80 X 100 FT. SHOULDER GRADING
422.2 S.Y. TYPE 5 AGGREGATE FOR BASE
422.22 S.Y. OPTIONAL PAVEMENT

OBLIT. - 272 S.Y.
EXIST. SHOULDER

OBLIT. - 96 S.Y.
EXIST. SHOULDER

OBLIT. - 156 S.Y.
EXIST. SHOULDER

OBLIT. - 422 S.Y.
EXIST. SHOULDER

4' INSIDE SHOULDER

10' OUTSIDE SHOULDER

EXISTING BRIDGE APPROACH SLAB

EXISTING BRIDGE APPROACH SLAB

BRIDGE A12902

BRIDGE A12903

MATCHLINE STA. 219+05.00

NOTE: SHOULDERS THAT WILL RECEIVE TRAFFIC (AS SHOWN ON THE TRAFFIC CONTROL PLAN) SHALL BE RECONSTRUCTED PRIOR TO THE SHIFTING OF TRAFFIC ONTO THE SHOULDER.

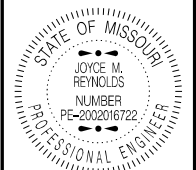

DATE PREPARED
10/3/2024

ROUTE	STATE
I - 29	MO
DISTRICT	SHEET NO.
NW	7

COUNTY
ANDREW

JOB NO.
J113262

CONTRACT ID.

PROJECT NO.

BRIDGE NO.

DATE	DESCRIPTION

MISSOURI HIGHWAYS AND TRANSPORTATION COMMISSION

105 WEST CAPITOL
JEFFERSON CITY, MO 65102
1-888-ASK-MODOT (1-888-275-6636)

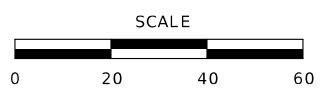

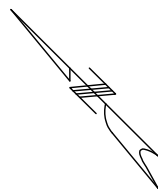

220

221

222

223

224

STA. 224+16.77 TO STA. 226+15.00 N.B.L. O/S SHLDR.
 BUILD 1.98 X 100 FT. SHAPING SLOPES, CLASS I
 (SHAPING OF FORESLOPE FOLLOWING REMOVAL OF EXISTING GUARDRAIL)

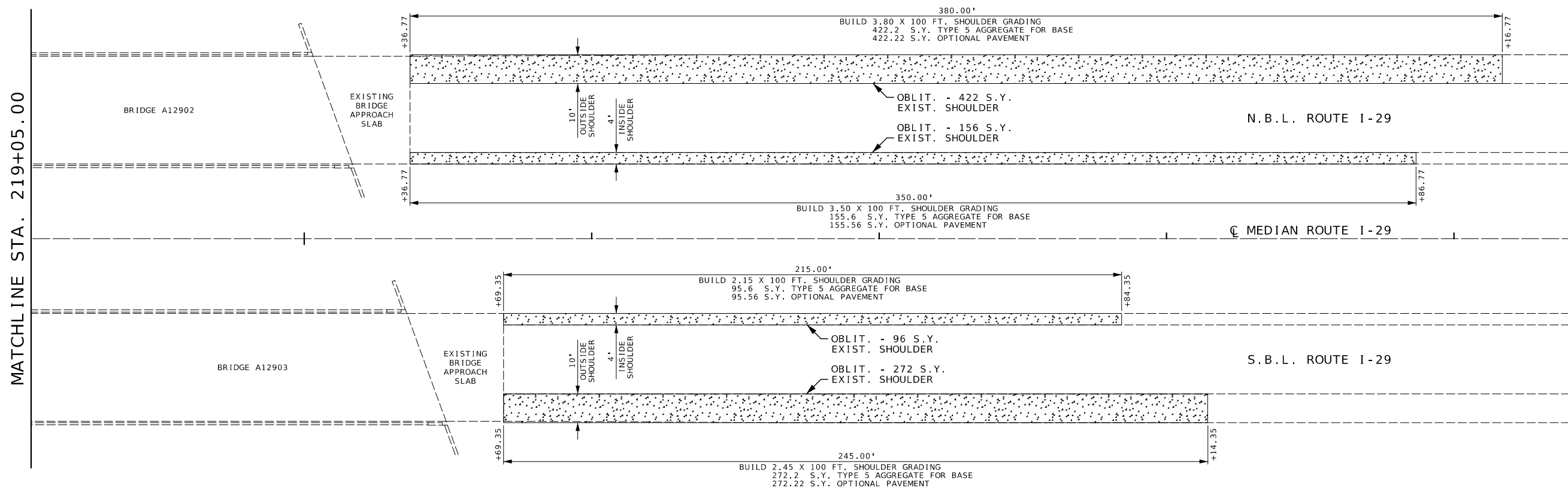

NOTE: SHOULDERS THAT WILL RECEIVE TRAFFIC (AS SHOWN ON THE TRAFFIC CONTROL PLAN) SHALL BE RECONSTRUCTED PRIOR TO THE SHIFTING OF TRAFFIC ONTO THE SHOULDER.

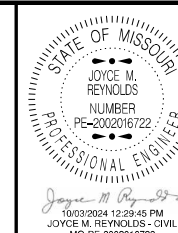
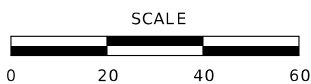

DATE PREPARED
10/3/2024

ROUTE I-29 STATE MO
DISTRICT NW SHEET NO. 8

COUNTY ANDREW

JOB NO. J113262

CONTRACT ID.

PROJECT NO.

BRIDGE NO.

DATE	DESCRIPTION

MISSOURI HIGHWAYS AND TRANSPORTATION COMMISSION

105 WEST CAPITOL
JEFFERSON CITY, MO 65102
1-888-ASK-MODOT (1-888-275-6636)

ROAD WORK
NEXT 2 MILES

GO20-1

1

END
ROAD WORK

GO20-2

26

WORK ZONE
NO PHONE
ZONE

CONST-8

56

Bridge
Improvements
MoDOT Fall 2025

CONST-5

57

CHANGEABLE
MESSAGE
SIGN

XX
SIGN

SIGN 57 SHALL BE PLACED IN A VISIBLE AREA WITHIN THE PROJECT LIMITS PROVIDED ITS LOCATION DOES NOT DISRUPT A SEQUENCE OF SIGNS. IF A VISIBLE LOCATION WITHIN THE PROJECT LIMITS IS NOT AVAILABLE, THE SIGN MAY BE PLACED 500 FEET BEFORE SIGN 1.

CHANGEABLE MESSAGE SIGN TO BE PLACED AT A LOCATION APPROVED BY THE ENGINEER

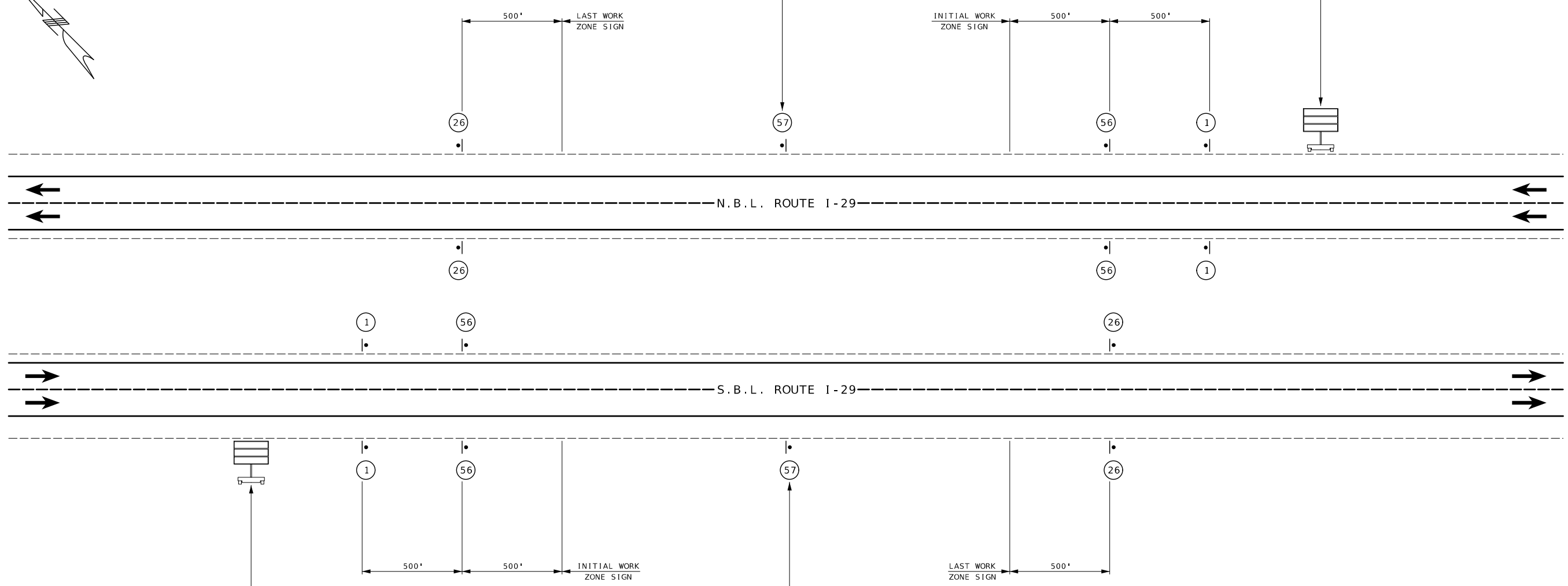
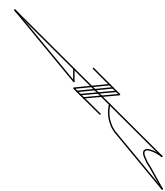

CHANGEABLE MESSAGE SIGN TO BE PLACED AT A LOCATION APPROVED BY THE ENGINEER

SIGN 57 SHALL BE PLACED IN A VISIBLE AREA WITHIN THE PROJECT LIMITS PROVIDED ITS LOCATION DOES NOT DISRUPT A SEQUENCE OF SIGNS. IF A VISIBLE LOCATION WITHIN THE PROJECT LIMITS IS NOT AVAILABLE, THE SIGN MAY BE PLACED 500 FEET BEFORE SIGN 1.



DATE PREPARED
10/3/2024 12:29:54 PM

JOYCE M. REYNOLDS, P.E.
MO-PE-2002016722

ROUTE
I-29

STATE
MO

DISTRICT
NW

SHEET NO.
9

COUNTY
ANDREW

JOB NO.
J113262

CONTRACT ID.

PROJECT NO.

BRIDGE NO.

DESCRIPTION

DATE

MISSOURI HIGHWAYS AND TRANSPORTATION COMMISSION

105 WEST CAPITOL
JEFFERSON CITY, MO 65102
1-888-ASK-MODOT (1-888-275-6636)

MoDOT

COMMISSION

NOT TO SCALE

BEGINNING AND END OF PROJECT

TRAFFIC CONTROL
SHEET 1 OF 12



WO20-1
2



R2-1
4



WO20-5
5

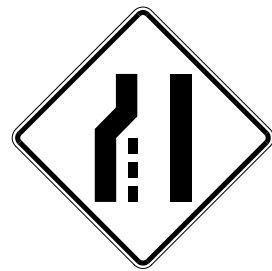

WO4-2L
6L

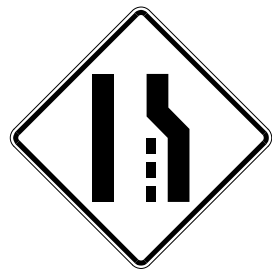

WO4-2R
6R



R2-1
25



R4-1
46



R4-2
46A



CONST-3A / CONST-3X
53



GO20-5aP
54

NOTE: QUANTITIES PROVIDE FOR TWO CONCURRENT LANE CLOSURE SETUPS WITH ONE-MILE WORK AREAS.



CHANNELIZERS



DIRECTIONAL INDICATOR BARRICADES (WITH SEQUENTIAL FLASHING WARNING LIGHTS)

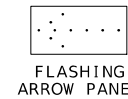

FLASHING ARROW PANEL



SIGN

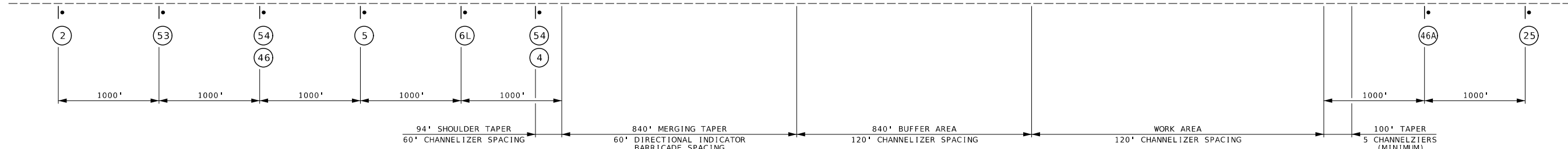
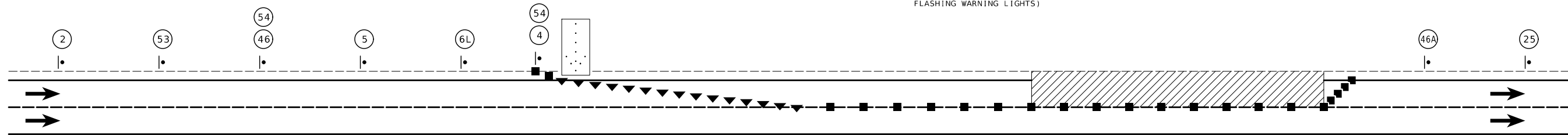

INSIDE (LEFT) LANE CLOSURE

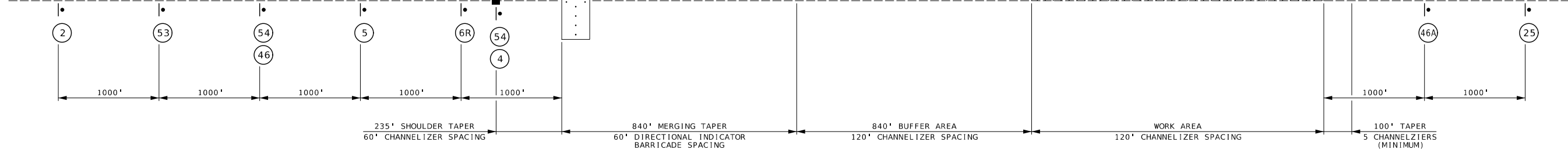
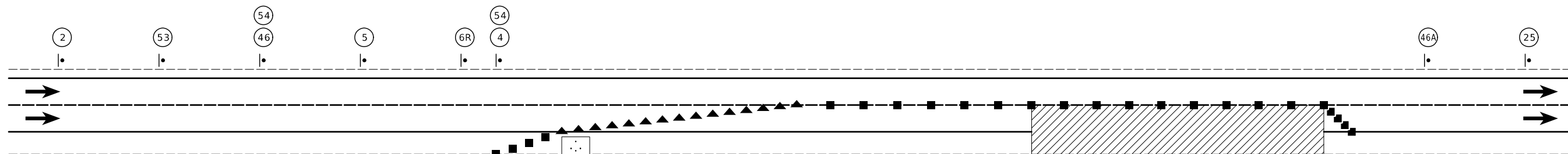

OUTSIDE (RIGHT) LANE CLOSURE

LANE CLOSURE (WITHOUT TEMPORARY TRAFFIC BARRIER)

NOT TO SCALE

TRAFFIC CONTROL SHEET 2 OF 12

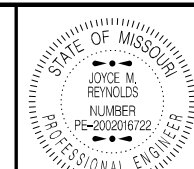

JOYCE M. REYNOLDS
NUMBER PE-2002016722
PROFESSIONAL ENGINEER

DATE PREPARED 10/3/2024
ROUTE I-29 STATE MO
DISTRICT NW SHEET NO. 10
COUNTY ANDREW
JOB NO. J113262
CONTRACT ID.

PROJECT NO.
BRIDGE NO.

DESCRIPTION

MISSOURI HIGHWAYS AND TRANSPORTATION COMMISSION
105 WEST CAPITOL JEFFERSON CITY, MO 65102
1-888-ASK-MODOT (1-888-275-6636)



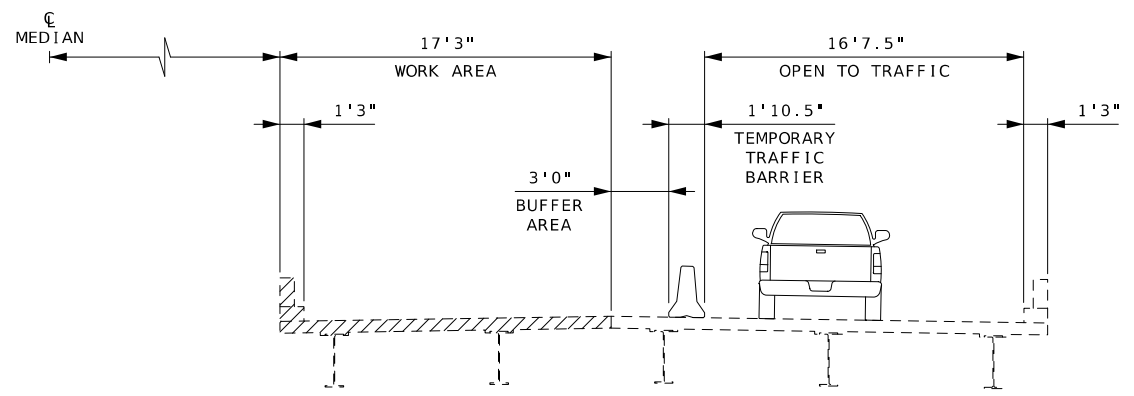

SECTION ON TANGENT
 INSIDE (LEFT) LANE CLOSURE WITH
 TEMPORARY TRAFFIC BARRIER
 SEE SHEETS 12-14

NOTE: SOUTHBOUND BRIDGE SHOWN; NORTHBOUND IS SIMILAR.

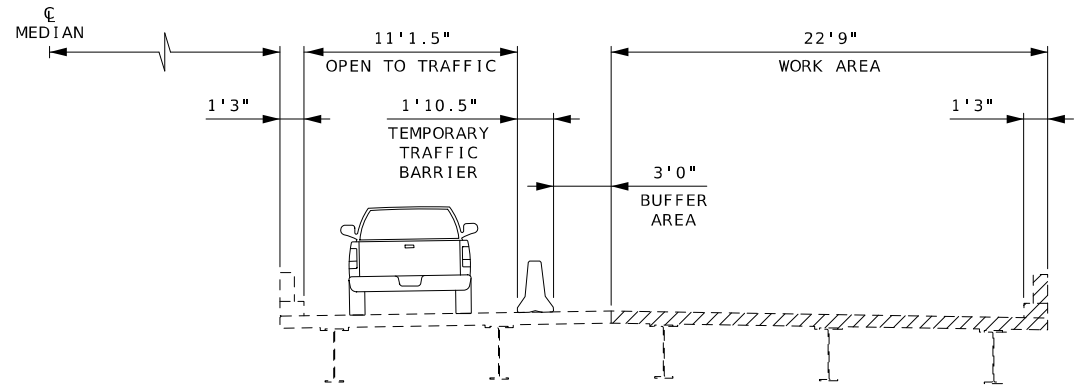

SECTION ON TANGENT
 OUTSIDE (RIGHT) LANE CLOSURE WITH
 TEMPORARY TRAFFIC BARRIER
 SEE SHEETS 15-19

NOT TO SCALE

TYPICAL SECTIONS - LANE CLOSURES WITH TEMPORARY TRAFFIC BARRIER

TRAFFIC CONTROL
 SHEET 3 OF 12

STATE OF MISSOURI
 JOYCE M. REYNOLDS
 NUMBER
 PE-2002016722
 PROFESSIONAL ENGINEER

Joyce M. Reynolds
 10/03/2024 12:29:11 PM
 JOYCE M. REYNOLDS - CIVIL
 MO-PE-2002016722

DATE PREPARED
 10/3/2024

ROUTE 1-29	STATE MO
DISTRICT NW	SHEET NO. 11

COUNTY
ANDREW

JOB NO.
J113262

CONTRACT ID.

PROJECT NO.

BRIDGE NO.

DATE	DESCRIPTION

MISSOURI HIGHWAYS AND TRANSPORTATION
 COMMISSION

MoDOT
 MISSOURI HIGHWAYS AND TRANSPORTATION
 COMMISSION

105 WEST CAPITOL
 JEFFERSON CITY, MO 65102
 1-888-ASK-MODOT (1-888-275-6636)



WO20-1
2



R2-1
4



WO20-5
5

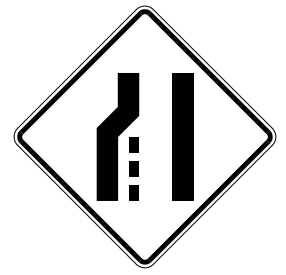

WO4-2L
6L



R2-1
25



GO20-5aP
54



SIGN

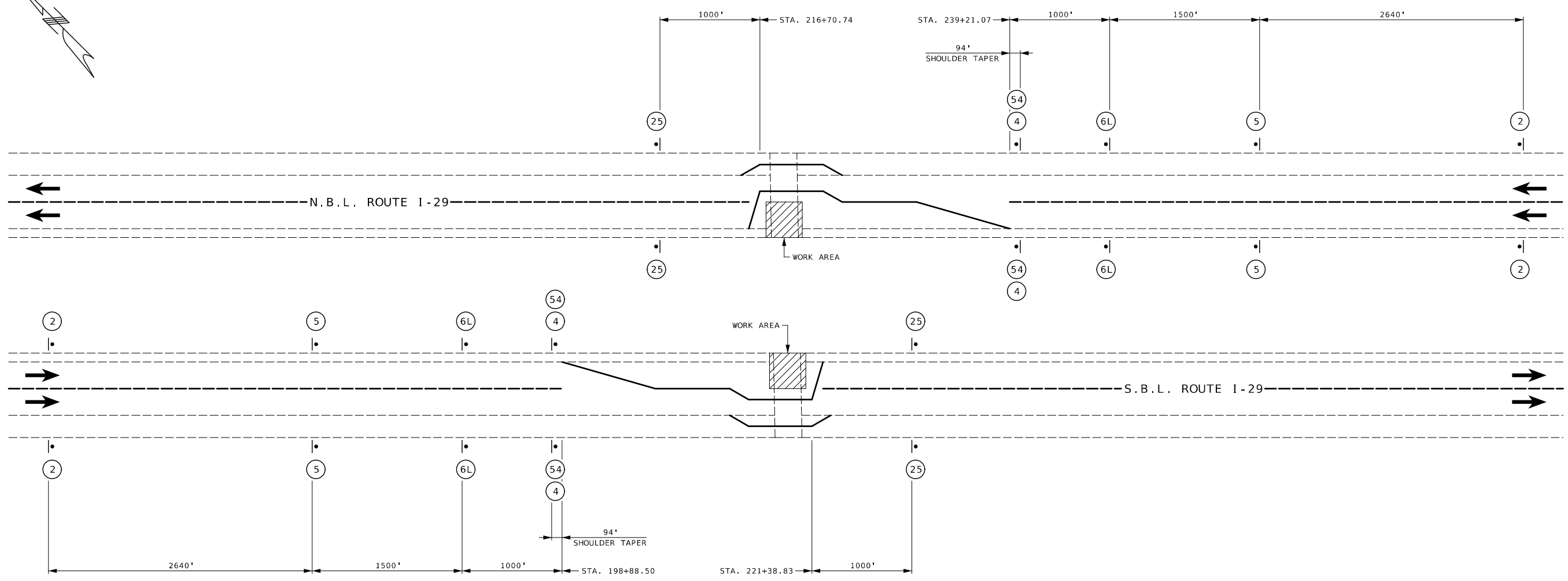
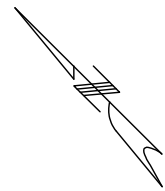

NOT TO SCALE

WORK ON INSIDE (LEFT) LANES - ADVANCE WARNING AND TERMINATION AREA SIGNING

TRAFFIC CONTROL
SHEET 4 OF 12

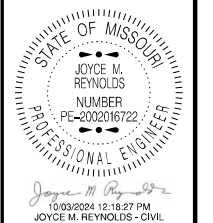

DATE PREPARED
10/3/2024

ROUTE I-29	STATE MO
DISTRICT NW	SHEET NO. 12

COUNTY
ANDREW

JOB NO.
J113262

CONTRACT ID.

PROJECT NO.

BRIDGE NO.

DATE	DESCRIPTION

MISSOURI HIGHWAYS AND TRANSPORTATION COMMISSION

105 WEST CAPITOL
JEFFERSON CITY, MO 65102
1-888-ASK-MODOT (1-888-275-6636)

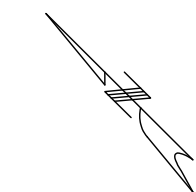

195

200

205

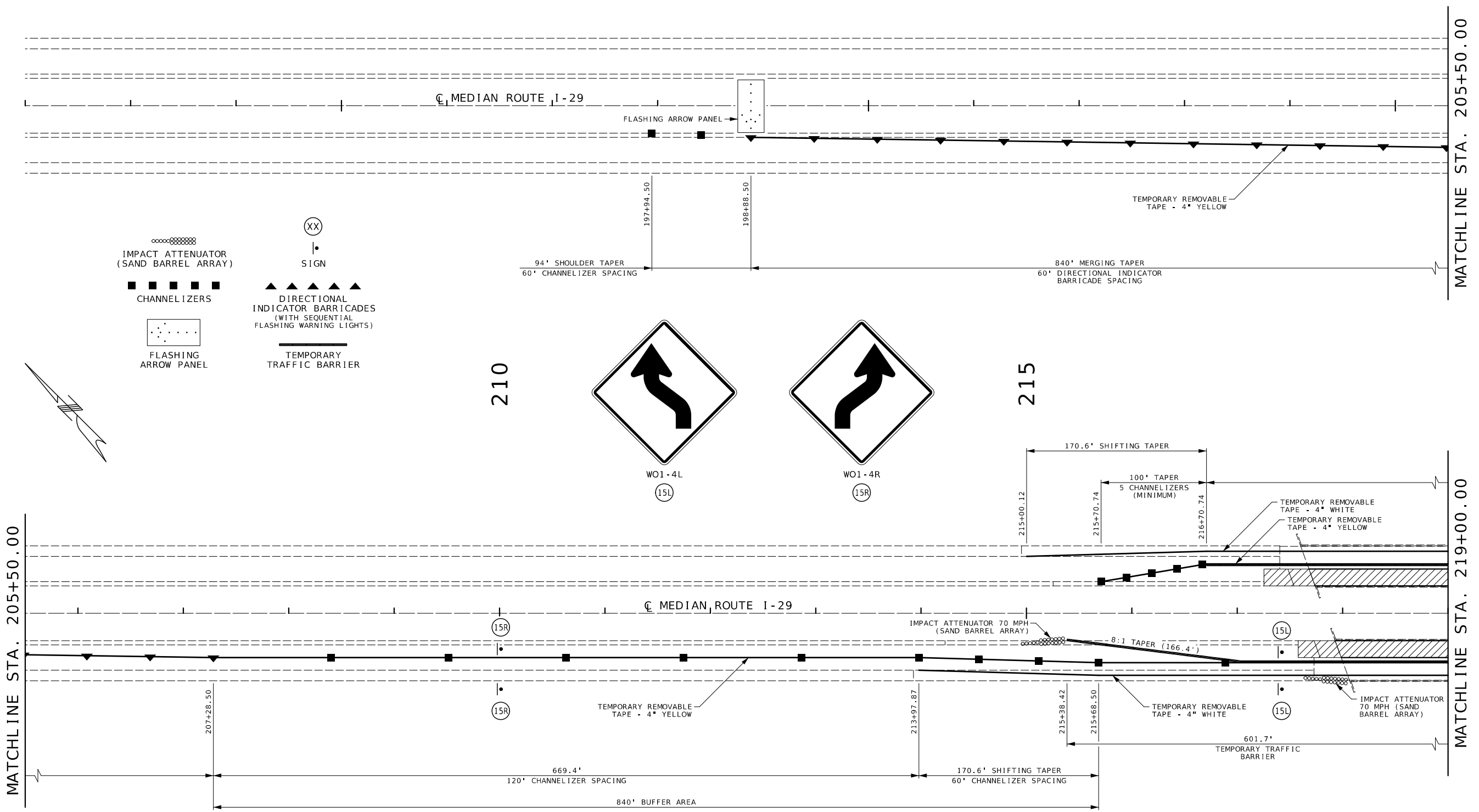

MATCHLINE STA. 205+50.00

MATCHLINE STA. 219+00.00

LEGEND

- IMPACT ATTENUATOR (SAND BARREL ARRAY)
- CHANNELIZERS
- FLASHING ARROW PANEL
- SIGN
- DIRECTIONAL INDICATOR BARRICADES (WITH SEQUENTIAL FLASHING WARNING LIGHTS)
- TEMPORARY TRAFFIC BARRIER

210

215

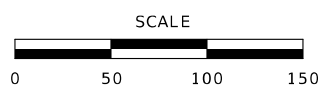

WORK ON INSIDE (LEFT) LANES - TRANSITION AND ACTIVITY AREA DETAILS

TRAFFIC CONTROL SHEET 5 OF 12

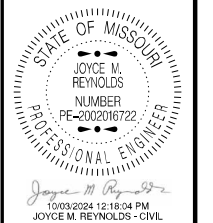

DATE PREPARED
10/3/2024

ROUTE I-29	STATE MO
DISTRICT NW	SHEET NO. 13
COUNTY ANDREW	
JOB NO. J113262	
CONTRACT ID.	
PROJECT NO.	
BRIDGE NO.	

DATE	DESCRIPTION

MISSOURI HIGHWAYS AND TRANSPORTATION COMMISSION

105 WEST CAPITOL
JEFFERSON CITY, MO 65102
1-888-ASK-MODOT (1-888-273-6636)

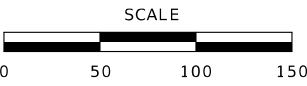
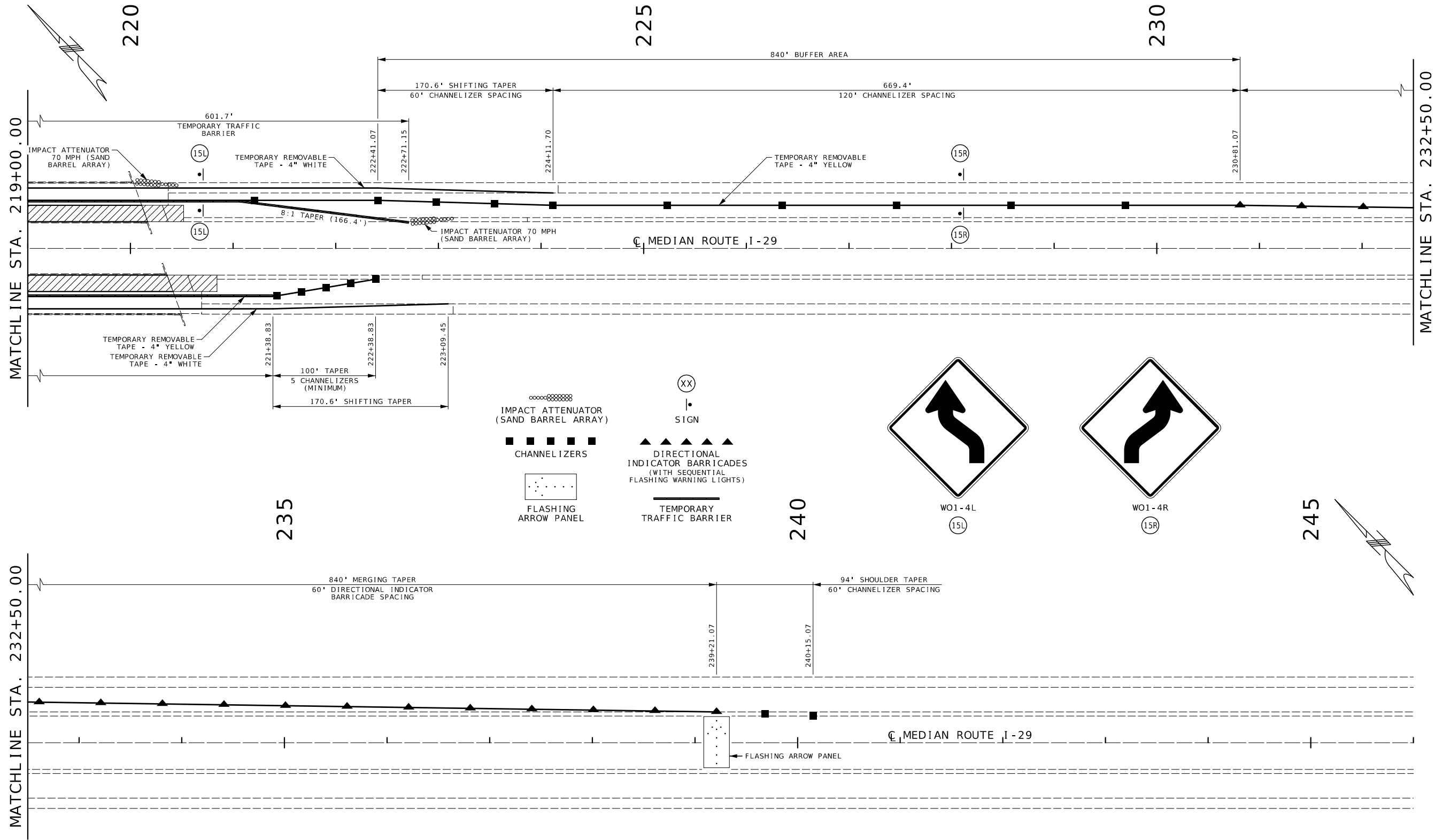

WORK ON INSIDE (LEFT) LANES - TRANSITION AND ACTIVITY AREA DETAILS



DATE PREPARED
10/3/2024

ROUTE	STATE
I - 29	MO
DISTRICT	SHEET NO.
NW	14

COUNTY
ANDREW

JOB NO.
J113262

CONTRACT ID.

PROJECT NO.

BRIDGE NO.

DESCRIPTION	DATE

MISSOURI HIGHWAYS AND TRANSPORTATION COMMISSION

105 WEST CAPITOL
JEFFERSON CITY, MO 65102
1-888-ASK-MODOT (1-888-275-6636)



WO20-1
(2)



R2-1
(4)



WO20-5
(5)

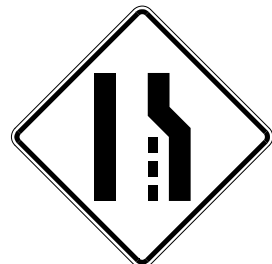

WO4-2R
(6R)



R2-1
(25)



WO5-1
(43)

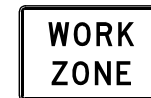

GO20-5aP
(54)



SIGN

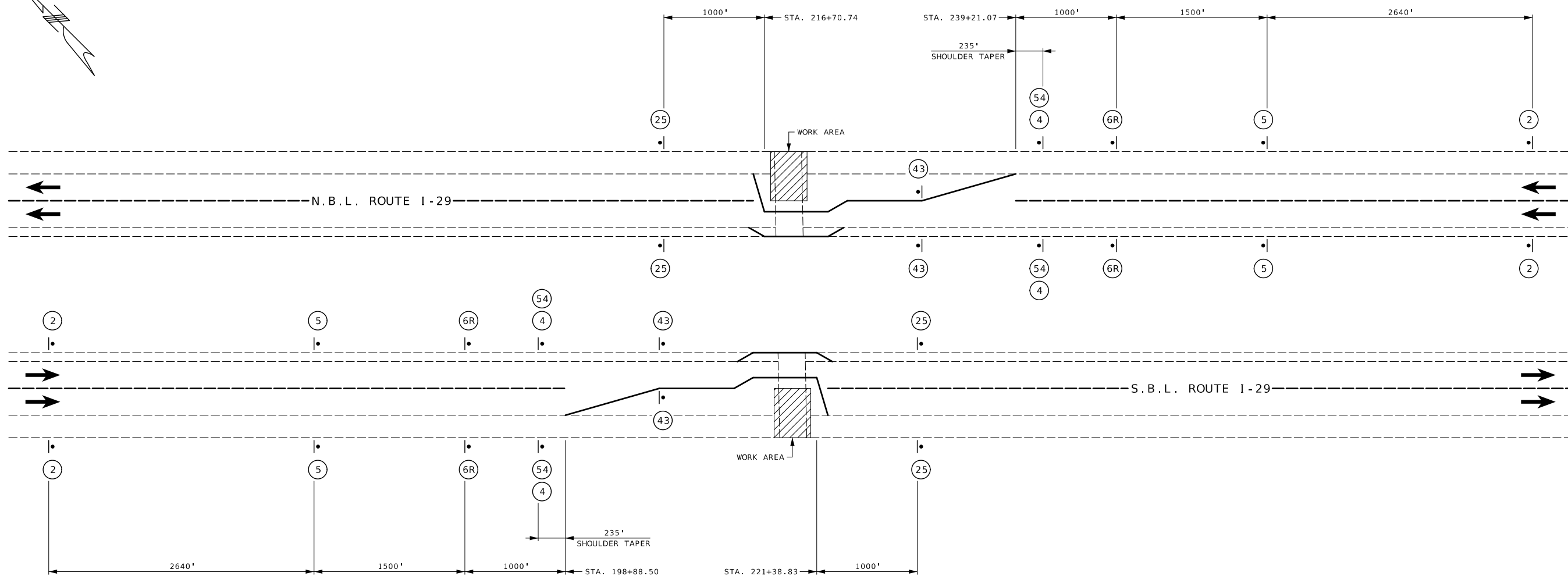
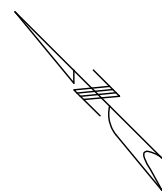

NOT TO SCALE

WORK ON OUTSIDE (RIGHT) LANES - ADVANCE WARNING AND TERMINATION AREA SIGNING

TRAFFIC CONTROL
SHEET 7 OF 12

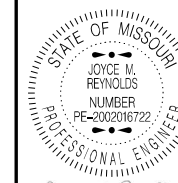

DATE PREPARED
10/3/2024

ROUTE	STATE
I - 29	MO
DISTRICT	SHEET NO.
NW	15

COUNTY
ANDREW
JOB NO.
J113262
CONTRACT ID.

PROJECT NO.
BRIDGE NO.

DESCRIPTION	DATE

MISSOURI HIGHWAYS AND TRANSPORTATION COMMISSION

105 WEST CAPITOL
JEFFERSON CITY, MO 65102
1-888-ASK-MODOT (1-888-275-6636)

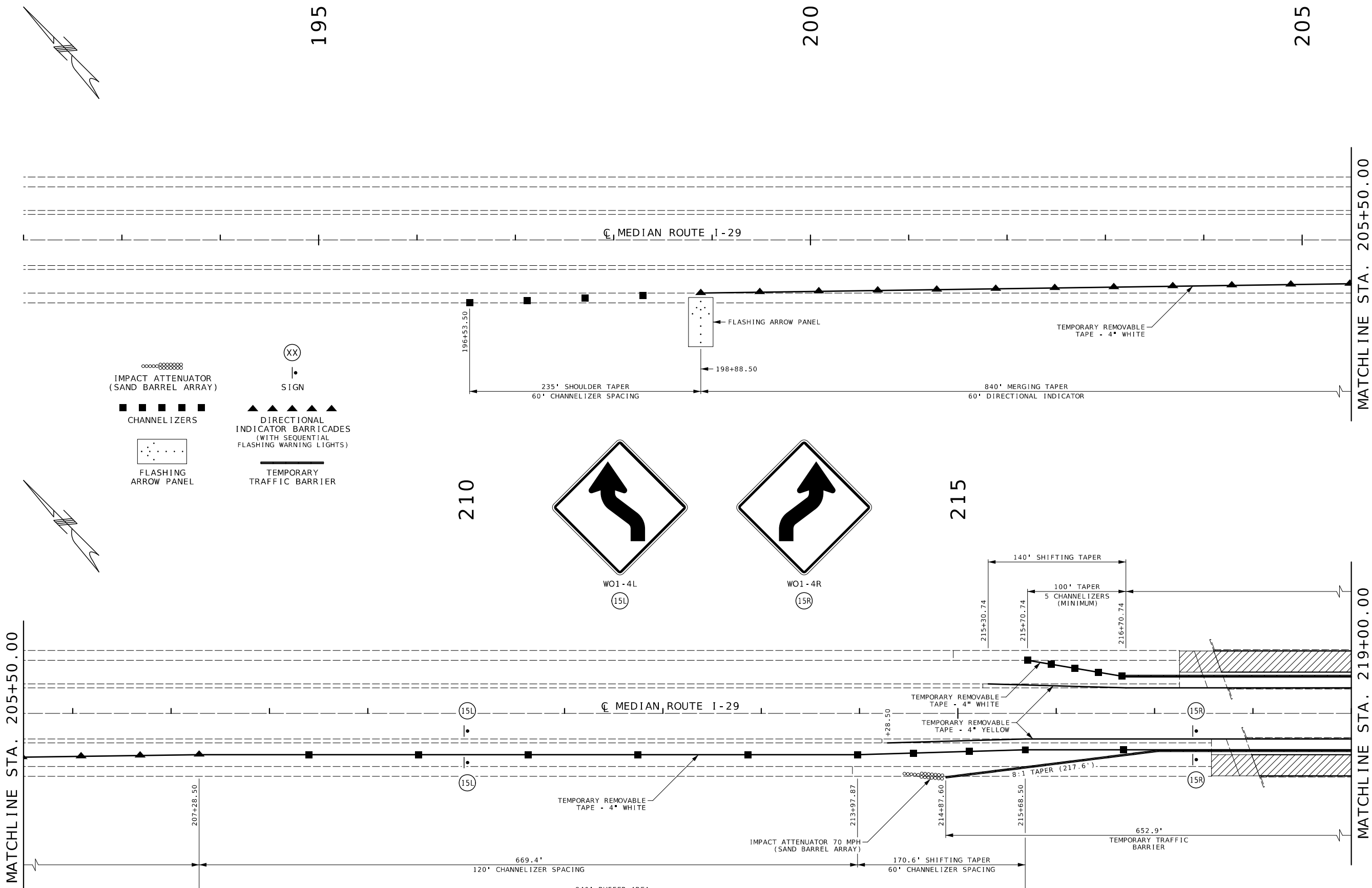

IMPACT ATTENUATOR (SAND BARREL ARRAY)
 CHANNELIZERS
 FLASHING ARROW PANEL
 SIGN
 DIRECTIONAL INDICATOR BARRICADES (WITH SEQUENTIAL FLASHING WARNING LIGHTS)
 TEMPORARY TRAFFIC BARRIER

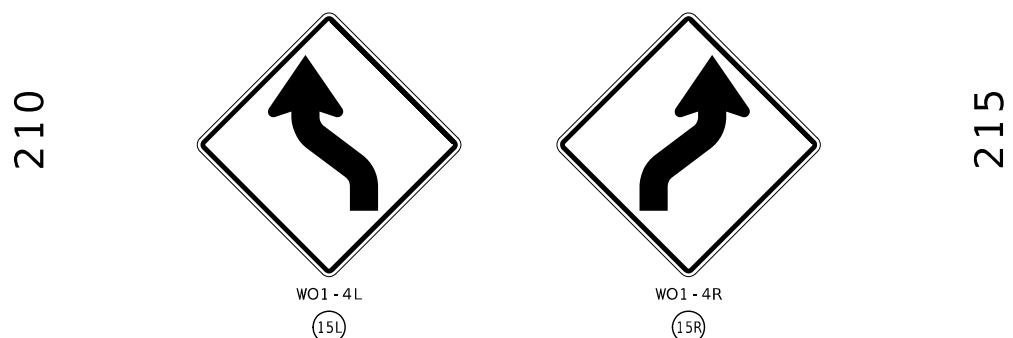

WORK ON OUTSIDE (RIGHT) LANES - TRANSITION AND ACTIVITY AREA DETAILS

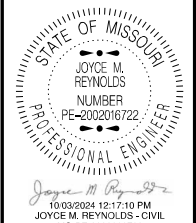

DATE PREPARED: 10/3/2024

ROUTE	STATE
I - 29	MO
DISTRICT	SHEET NO.
NW	16

COUNTY: ANDREW
 JOB NO.: J113262
 CONTRACT ID.:
 PROJECT NO.:
 BRIDGE NO.:

DATE	DESCRIPTION

MISSOURI HIGHWAYS AND TRANSPORTATION COMMISSION

105 WEST CAPITOL JEFFERSON CITY, MO 65102
 1-888-ASK-MODOT (1-888-273-6636)

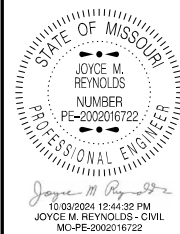
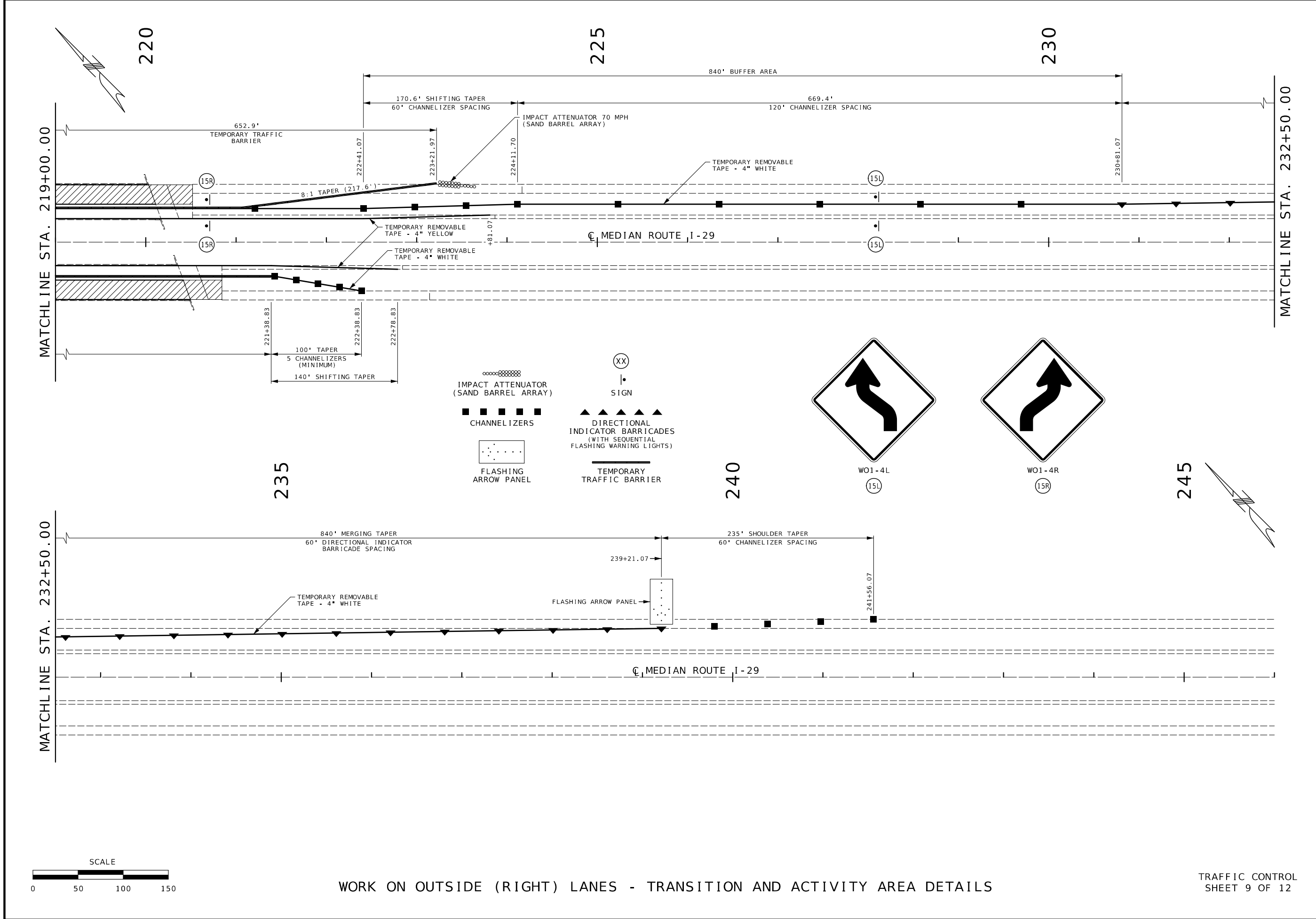

DATE PREPARED
10/3/2024

ROUTE I-29 STATE MO

DISTRICT NW SHEET NO. 17

COUNTY ANDREW

JOB NO. J113262

CONTRACT ID.

PROJECT NO.

BRIDGE NO.

DATE	DESCRIPTION

MISSOURI HIGHWAYS AND TRANSPORTATION COMMISSION

MoDOT

105 WEST CAPITOL
JEFFERSON CITY, MO 65102
1-888-ASK-MODOT (1-888-275-6636)



WORK ON OUTSIDE (RIGHT) LANES - TRANSITION AND ACTIVITY AREA DETAILS



NOTE: SEE SHEET 19 FOR SPECIAL SIGN DETAILS.

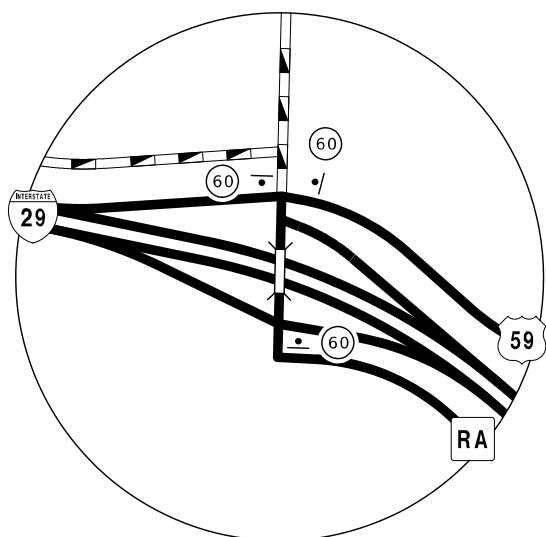
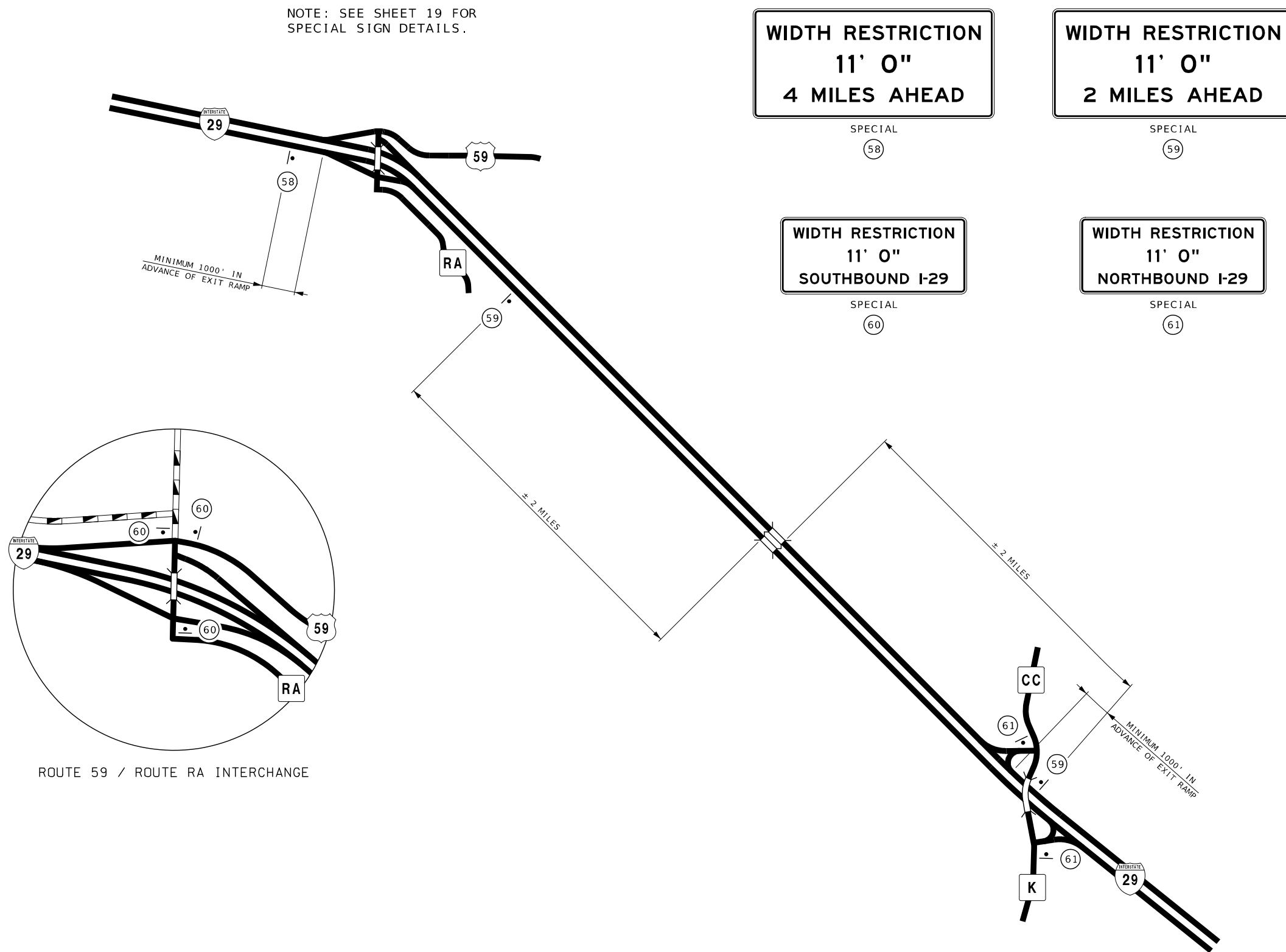

ROUTE 59 / ROUTE RA INTERCHANGE

NOT TO SCALE

WORK ON OUTSIDE (RIGHT) LANES - WIDTH RESTRICTION SIGNING

TRAFFIC CONTROL
SHEET 10 OF 12

STATE OF MISSOURI
JOYCE M. REYNOLDS
NUMBER
PE-2002016722
PROFESSIONAL ENGINEER

10/03/2024 12:44:48 PM
JOYCE M. REYNOLDS - CIVIL
MO-PE-2002016722

DATE PREPARED
10/3/2024

ROUTE	STATE
I - 29	MO
DISTRICT	SHEET NO.
NW	18

COUNTY
ANDREW

JOB NO.
J113262

CONTRACT ID.

PROJECT NO.

BRIDGE NO.

DATE	DESCRIPTION

MISSOURI HIGHWAYS AND TRANSPORTATION COMMISSION

MoDOT

105 WEST CAPITOL
JEFFERSON CITY, MO 65102
1-888-ASK-MODOT (1-888-275-6636)

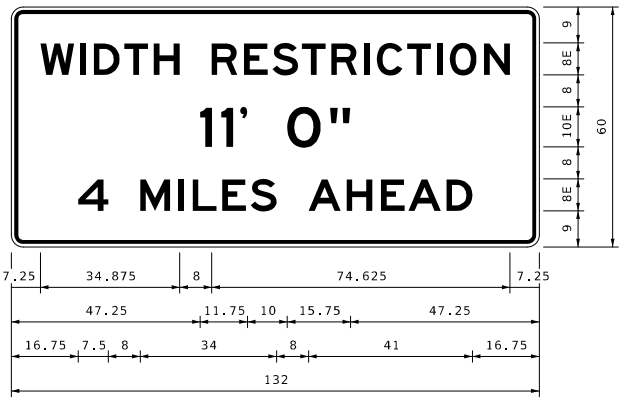

58 SPECIAL

3.000" RADIUS, 1.000" BORDER, 0.750" INDENT, BLACK ON ORANGE;
 [WIDTH] 8E; [RESTRICTION] 8E; [11'] 10E; [0"] 10E;
 [4] 8E; [MILES] 8E; [AHEAD] 8E;

TABLE OF LETTER AND OBJECT LEFTS:

W	I	D	T	H						
7.250	17.125	20.625	28.250	35.625						
R	E	S	T	R	I	C	T	I	O	N
50.125	58.250	65.375	72.625	80.000	88.125	91.375	99.000	106.375	109.625	118.250
I	I	'	O	"						
47.250	52.500	57.250	69.000	79.750						
4	M	I	L	E	S					
16.750	32.250	41.875	45.375	52.750	59.875					
A	H	E	A	D						
74.375	83.875	92.375	99.250	108.750						

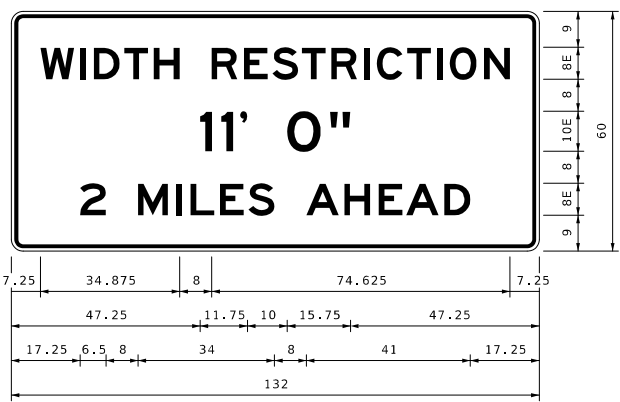

59 SPECIAL

3.000" RADIUS, 1.000" BORDER, 0.750" INDENT, BLACK ON ORANGE;
 [WIDTH] 8E; [RESTRICTION] 8E; [11'] 10E; [0"] 10E;
 [2] 8E; [MILES] 8E; [AHEAD] 8E;

TABLE OF LETTER AND OBJECT LEFTS:

W	I	D	T	H						
7.250	17.125	20.625	28.250	35.625						
R	E	S	T	R	I	C	T	I	O	N
50.125	58.250	65.375	72.625	80.000	88.125	91.375	99.000	106.375	109.625	118.250
I	I	'	O	"						
47.250	52.500	57.250	69.000	79.750						
2	M	I	L	E	S					
17.250	31.750	41.250	44.875	52.250	59.250					
A	H	E	A	D						
73.750	83.375	91.875	98.750	108.250						

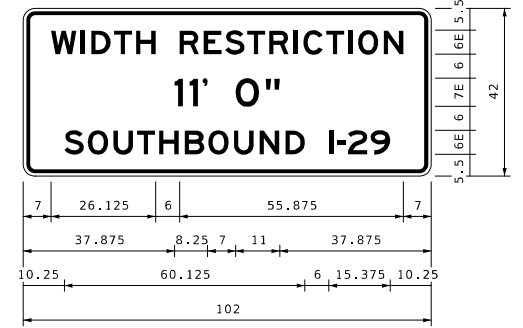

60 SPECIAL

3.000" RADIUS, 1.000" BORDER, 0.750" INDENT, BLACK ON ORANGE;
 [WIDTH] 6E; [RESTRICTION] 6E; [11'] 7E; [0"] 7E;
 [SOUTHBOUND] 6E; [I-29] 6E;

TABLE OF LETTER AND OBJECT LEFTS:

W	I	D	T	H						
7.000	14.375	17.000	22.750	28.250						
R	E	S	T	R	I	C	T	I	O	N
39.125	45.125	50.500	56.000	61.500	67.625	70.000	75.750	81.250	83.750	90.125
I	I	'	O	"						
37.875	41.625	44.875	53.125	60.625						
S	O	U	T	H	B	O	U	N	D	
10.250	16.125	22.625	28.500	34.000	40.375	46.250	52.750	59.125	65.500	
I	-	2	9							
76.375	78.500	81.125	86.875							

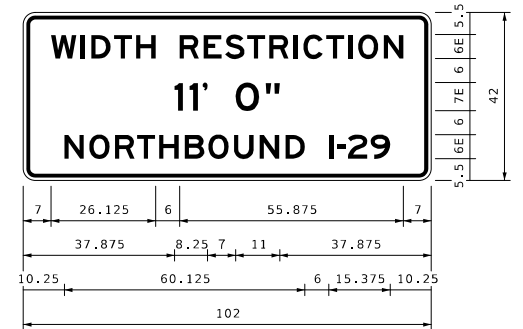

61 SPECIAL

3.000" RADIUS, 1.000" BORDER, 0.750" INDENT, BLACK ON ORANGE;
 [WIDTH] 6E; [RESTRICTION] 6E; [11'] 7E; [0"] 7E;
 [NORTHBOUND] 6E; [I-29] 6E;

TABLE OF LETTER AND OBJECT LEFTS:

W	I	D	T	H						
7.000	14.375	17.000	22.750	28.250						
R	E	S	T	R	I	C	T	I	O	N
39.125	45.125	50.500	56.000	61.500	67.625	70.000	75.750	81.250	83.750	90.125
I	I	'	O	"						
37.875	41.625	44.875	53.125	60.625						
N	O	R	T	H	B	O	U	N	D	
10.250	16.500	23.000	28.500	34.000	40.375	46.250	52.750	59.125	65.500	
I	-	2	9							
76.375	78.500	81.125	86.875							

NOT TO SCALE

WORK ON OUTSIDE (RIGHT) LANES - SPECIAL SIGN DETAILS

JOYCE M. REYNOLDS
 NUMBER PE-2002016722
 PROFESSIONAL ENGINEER

10/03/2024 12:44:57 PM
 JOYCE M. REYNOLDS - CIVIL
 MO-PE-2002016722

DATE PREPARED	
10/3/2024	
ROUTE	STATE
I-29	MO
DISTRICT	SHEET NO.
NW	19
COUNTY	
ANDREW	
JOB NO.	
J113262	
CONTRACT ID.	
PROJECT NO.	
BRIDGE NO.	
DESCRIPTION	DATE

MISSOURI HIGHWAYS AND TRANSPORTATION COMMISSION

105 WEST CAPITOL
 JEFFERSON CITY, MO 65102
 1-888-ASK-MODOT (1-888-275-6636)

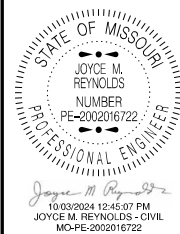

DATE PREPARED
10/3/2024

ROUTE STATE
I - 29 MO

DISTRICT SHEET NO.
NW 20

COUNTY
ANDREW

JOB NO.
J113262

CONTRACT ID.

PROJECT NO.

BRIDGE NO.

DESCRIPTION	DATE

MISSOURI HIGHWAYS AND TRANSPORTATION COMMISSION

105 WEST CAPITOL
JEFFERSON CITY, MO 65102
1-888-ASK-MODOT (1-888-275-6636)

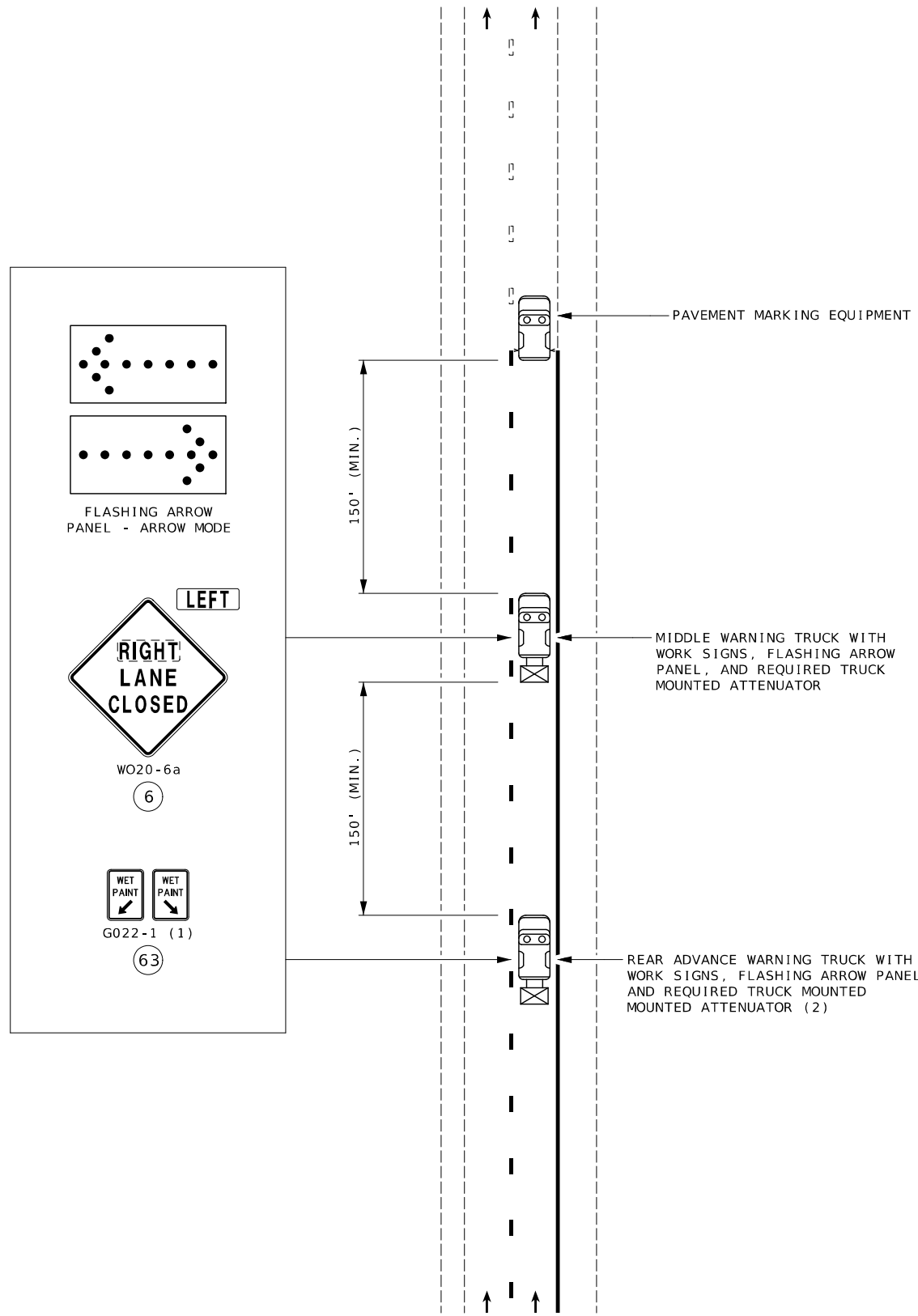

NOTES:

UPON APPROVAL OF THE ENGINEER, THE CONTRACTOR MAY PROVIDE ADDITIONAL PROTECTIVE TRUCKS EQUIPPED WITH PROPER WARNING DEVICES.

PROTECTIVE TRUCK AND WORK VEHICLES SHALL DISPLAY HIGH-INTENSITY ROTATING, FLASHING, OSCILLATING OR STROBE LIGHTS.

VEHICLE HAZARD WARNING SIGNALS SHALL NOT BE USED INSTEAD OF THE VEHICLE'S HIGH-INTENSITY ROTATING, ROTATING, FLASHING, OSCILLATING OR STROBE LIGHTS.

FLASHING ARROW PANELS SHALL BE INCIDENTAL TO TRUCK MOUNTED ATTENUATORS, WHEREVER USED, NO ADDITIONAL PAYMENT WILL BE MADE.

(1) WET PAINT SIGNS ARE INSTALLED TO INDICATE THE SIDE TO WHICH THE PAVEMENT MARKING MATERIAL IS BEING APPLIED. AT THE CONTRACTOR'S OPTION, A FRONT FACING WET PAINT SIGN MAY BE INSTALLED ON THE LEFT SIDE OF THE PAVEMENT MARKING EQUIPMENT.

(2) REAR ADVANCE WARNING TRUCK IS POSITIONED AT THE NO TRACK POINT OF THE PAVEMENT MARKING MATERIAL, OR VERTICAL OR HORIZONTAL CURVES THAT RESTRICT SIGHT DISTANCE, OR SPACING SHOWN.

NOT TO SCALE

MOVING OPERATION - PAVEMENT MARKING

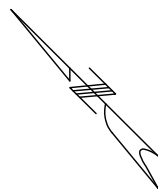

KEY TO SYMBOLS

ROCK DITCH CHECK	
INLET CHECK	
SILT FENCE	
SEEDING AND MULCH	

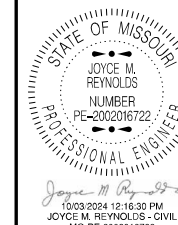

DATE PREPARED
10/3/2024

ROUTE	STATE
I - 29	MO
DISTRICT	SHEET NO.
NW	21

COUNTY

ANDREW

JOB NO.

J113262

CONTRACT ID.

PROJECT NO.

BRIDGE NO.

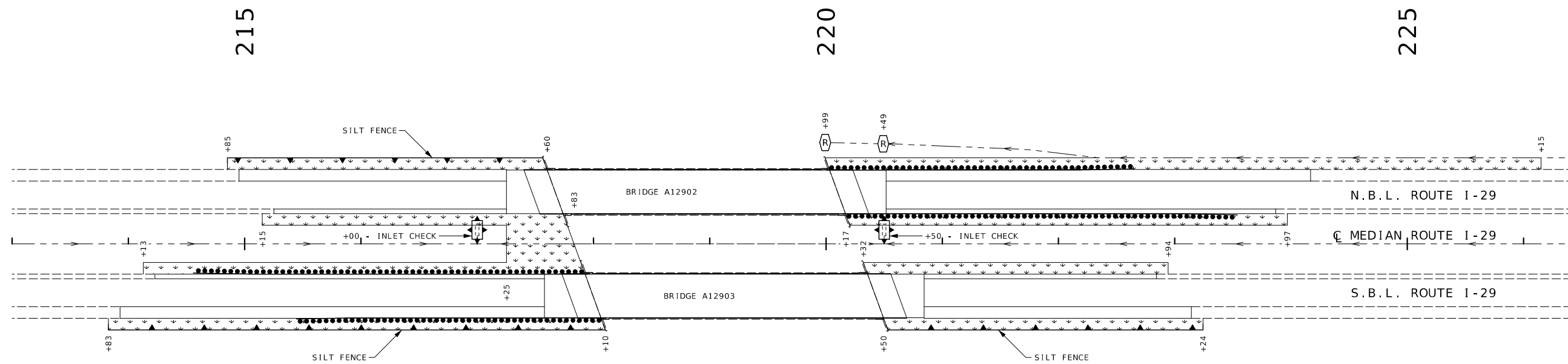

DATE	DESCRIPTION

MISSOURI HIGHWAYS AND TRANSPORTATION COMMISSION



105 WEST CAPITOL
JEFFERSON CITY, MO 65102
1-888-ASK-MODOT (1-888-275-6636)

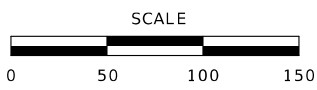

U.I.P. AND REHABILITATE EXISTING (46'-69'-69'-55') CONTINUOUS COMPOSITE WIDE FLANGE BEAM SPANS
(SKEW: 20° R.A.)

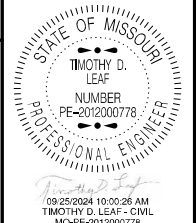

DATE PREPARED	
9/25/2024	
ROUTE	STATE
I-29	MO
DISTRICT	SHEET NO.
BR	1
COUNTY	
ANDREW	
JOB NO.	
J113262	
CONTRACT ID.	
PROJECT NO.	
BRIDGE NO.	
A12902	

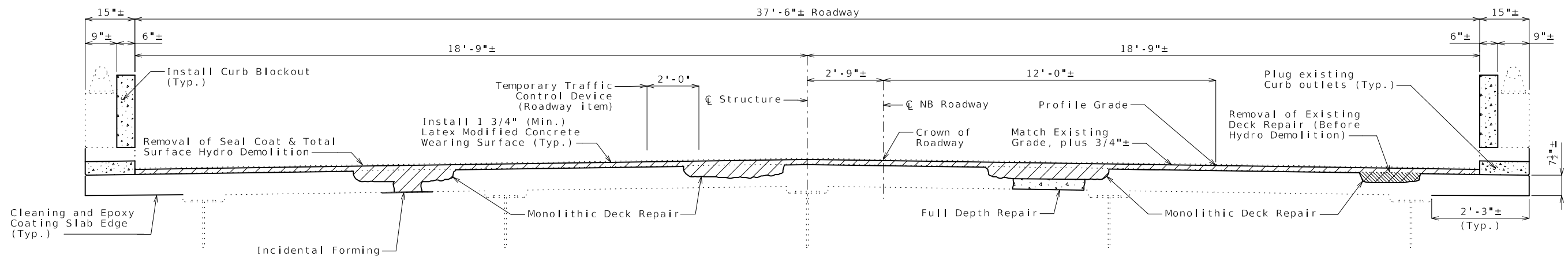

TYPICAL SECTION THRU EXISTING DECK

Note: For details of repairs to deck concrete, see Sheet No. 2.

Estimated Quantities		
Item		Total
Total Surface Hydro Demolition	sq. yard	1013
Removal of Seal Coat or Polymer Wearing Surface	sq. foot	9116
Removal of Existing Deck Repair	sq. foot	100
Bridge Approach Slab (Major)	sq. yard	175
* Supplementary Wearing Surface Material	cu. yard	12
Latex Modified Concrete Wearing Surface	sq. yard	1013
Diamond Grinding	sq. yard	1013
Curb Blockout	linear foot	481
Full Depth Repair	sq. foot	250
Plugging Existing Curb Outlets	each	19
Protective Coating - Concrete Bents and Piers (Epoxy)	lump sum	1
Cleaning and Coating Existing Bearings	each	10
Cored Slab Drain	each	26

General Notes:

Design Specifications:
2002 AASHTO LFD (17th Ed.) Standard Specifications
Bridge Deck Rating = 5

Design Loading:
HS20-44 (1961 & New Construction)

Design Unit Stresses:

Class B-1 Concrete (Curb Blockout) f'c = 4,000 psi
Class B-2 Concrete (Full Depth Repair) f'c = 4,000 psi

Contractor can use either Class B-1 or Class B-2 concrete or Wearing Surface material for Slab Drain plugs, same material shall be used throughout.

Concrete Protective Coatings:

Protective Coating for Concrete Bents and Piers (Epoxy) shall be applied as shown on the bridge plans and in accordance with Sec 711.

Miscellaneous:

Roadway surfacing adjacent to bridge ends shall match new bridge wearing surface (Roadway Item).

All concrete repairs shall be in accordance with Sec 704, unless otherwise noted.

Outline of existing work is indicated by light dashed lines. Heavy lines indicate new work.

Contractor shall verify all dimensions in field before ordering new material.

In order to maintain grade and a minimum thickness of wearing surface as shown on plans it may be necessary to use additional quantities of wearing surface at various locations throughout the structure. The cost of furnishing and installing the wearing surface will be considered completely covered in the contract unit price, including all additional labor, materials or equipment for variations in thickness of wearing surface.

Traffic Handling:

Traffic to be maintained on structure during construction. See roadway plans for traffic control.

* Supplementary wearing surface material for monolithic deck repair will be paid for at the fixed unit price in accordance with Sec 109.

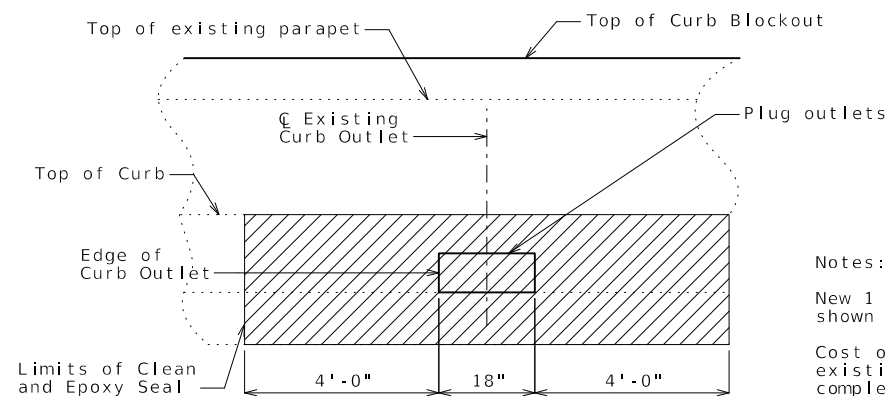

PART ELEVATION SHOWING CLEAN AND EPOXY SEAL AND PLUGGING OF CURB OUTLETS

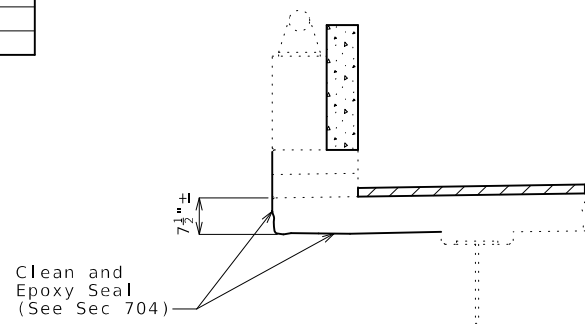

TYPICAL SECTION THRU EDGE OF SLAB SHOWING CLEAN AND EPOXY SEAL

Notes:

New 1 3/4" Latex Modified Concrete Overlay not shown for clarity.

Cost of labor and materials required to plug existing curb outlets will be considered completely covered by the contract unit price for Plugging Existing Curb Outlets, per each.

Estimated material required to fill all curb outlets is 0.4 cubic yards.

MISSOURI HIGHWAYS AND TRANSPORTATION COMMISSION



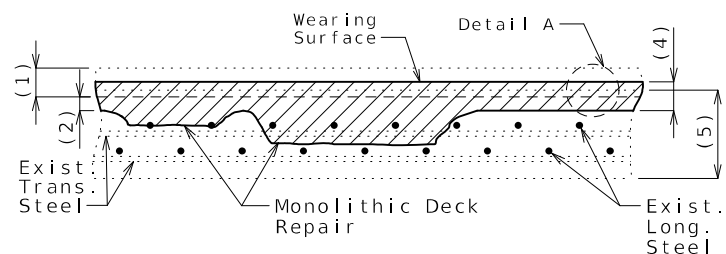

MONOLITHIC DECK REPAIR

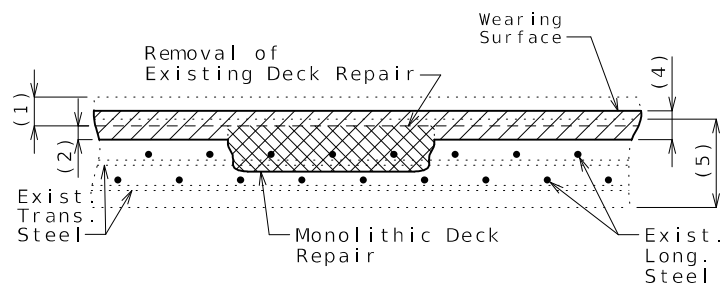

REMOVAL OF EXISTING DECK REPAIR BEFORE HYDRO DEMOLITION

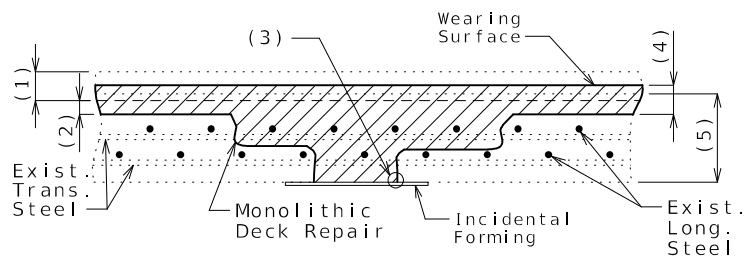

MONOLITHIC DECK REPAIR REQUIRING INCIDENTAL FORMING

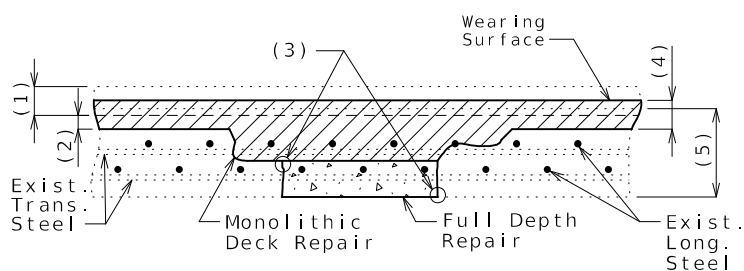

MONOLITHIC DECK REPAIR REQUIRING FULL DEPTH REPAIR

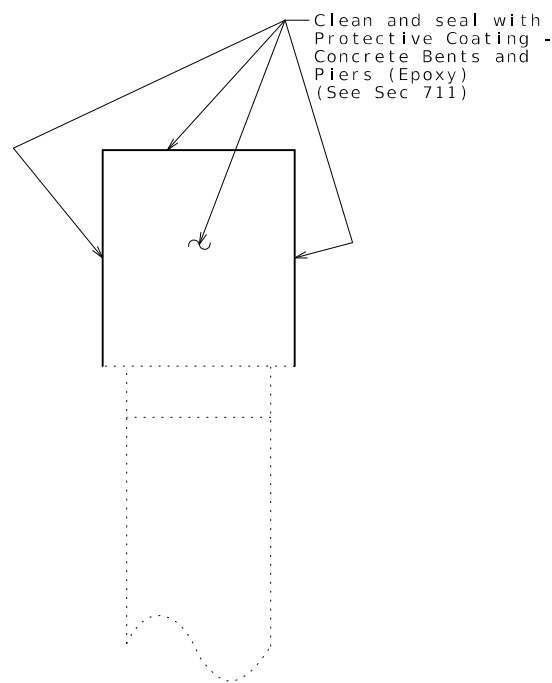

PART SECTION THRU EXISTING BEAM SHOWING PROTECTIVE COATING LIMITS (INT. BENTS NO. 2, 3, & 4)

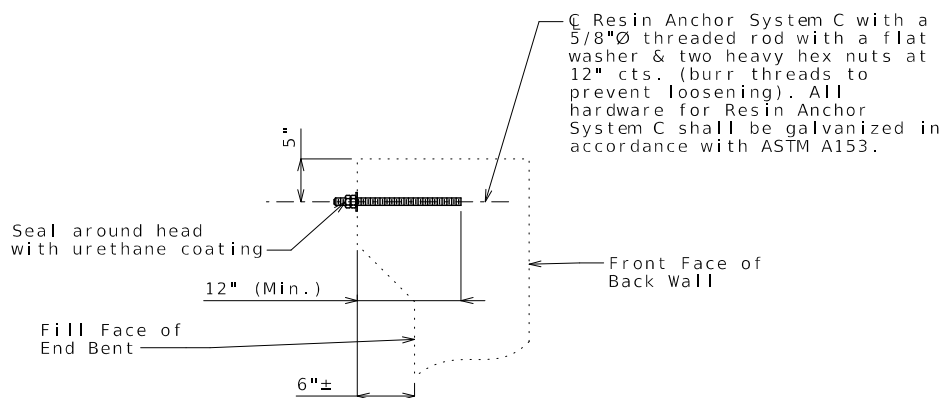

DETAILS OF RESIN ANCHOR SYSTEM AT END BENTS NO. 1 & 4

System C (54 total req'd.)

Note: The cost of applying protective coating to Intermediate Bents No. 2, 3, & 4 will be covered by the contract lump sum price for Protective Coating - Concrete Bents & Piers (Epoxy).

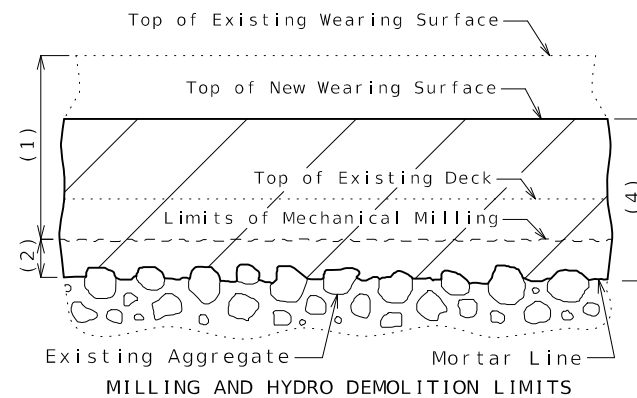

DETAIL A

- (1) Removal of existing wearing surface plus 1/2" thickness (min.) of existing bridge deck.
- (2) 1/2" minimum total surface hydro demolition of sound concrete, measured to mortar line.
- (3) 1" vertical side shall be established outside the deteriorated area.
- (4) 1 3/4" minimum latex modified concrete wearing surface
- (5) Original depth of deck plus wearing surface

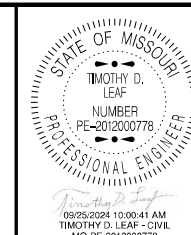

DATE PREPARED
9/25/2024

ROUTE 1-29 STATE MO

DISTRICT BR SHEET NO. 2

COUNTY ANDREW

JOB NO. J113262

CONTRACT ID.

PROJECT NO.

BRIDGE NO. A12902

DESCRIPTION

DATE

MISSOURI HIGHWAYS AND TRANSPORTATION COMMISSION



105 WEST CAPITOL JEFFERSON CITY, MO 65102 1-888-ASK-MODOT (1-888-275-6636)

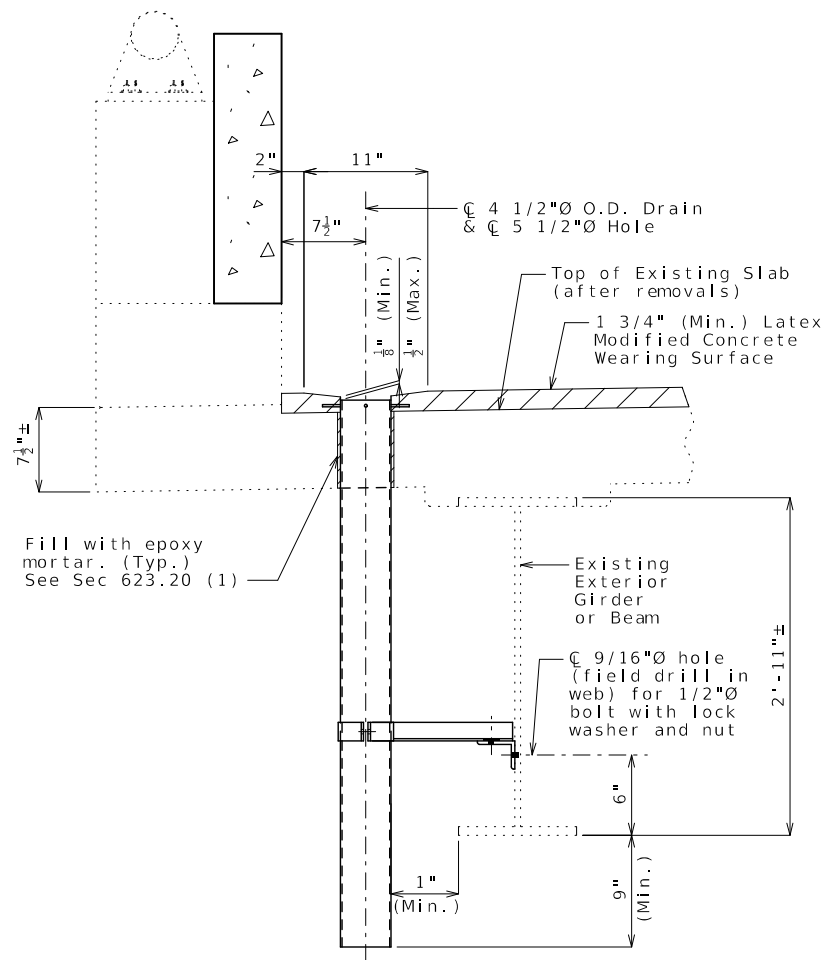

(1) Use backer rod around drain @ bottom of slab and epoxy inject from the top.

PART SECTION NEAR DRAIN

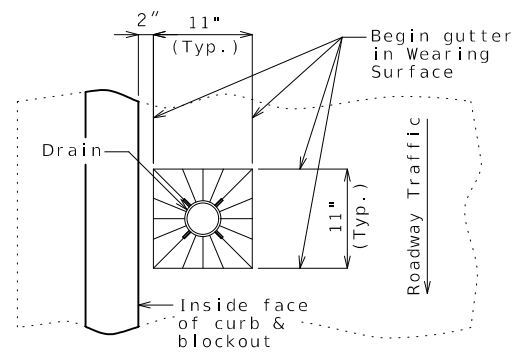

PART PLAN OF SLAB AT DRAIN

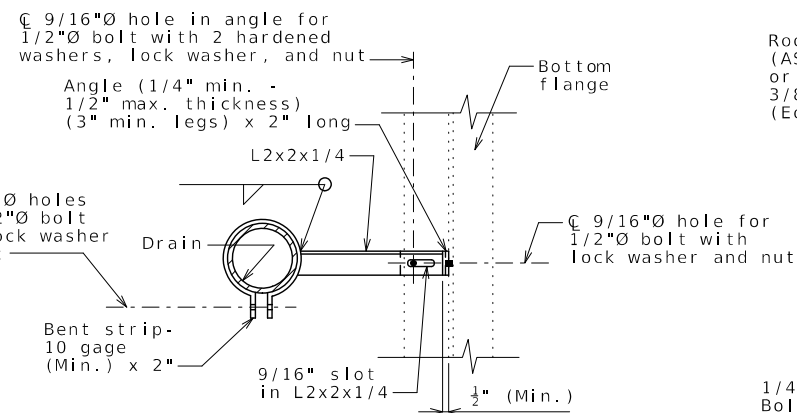

PART SECTION SHOWING BRACKET ASSEMBLY

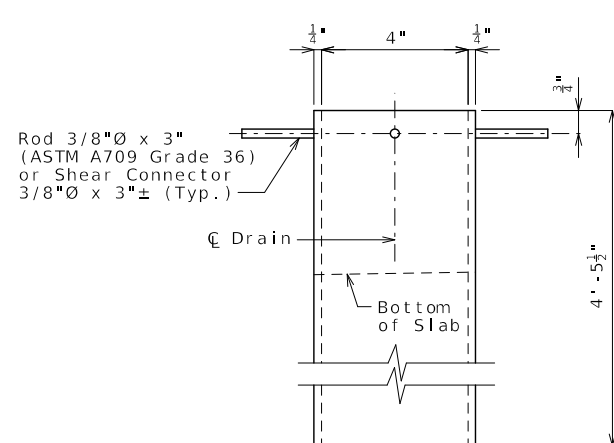

ELEVATION OF DRAIN

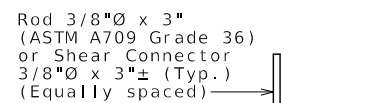

PLAN OF DRAIN

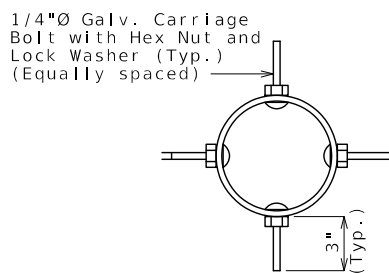

PLAN OF OPTIONAL FRP DRAIN

General Notes:

Contractor shall have the option to construct either steel or FRP slab drains. All drains shall be of same type.

Slab drain bracket assembly shall be ASTM A709 Grade 36 steel.

The bracket assembly shall be galvanized in accordance with ASTM A123.

All bolts, hardened washers, lock washers and nuts shall be galvanized in accordance with AASHTO M232 (ASTM A153), Class C.

All 1/2-inch diameter bolts shall be ASTM A307, except as noted.

Shop drawings will not be required for the slab drains and the bracket assembly.

Cost of cored slab drains, complete in place, will be considered completely covered by the contract unit price for Cored Slab Drain per each.

Holes for slab drains shall be cored. Percussion drilling will not be permitted.

Slab drain locations may be shifted the minimum extent necessary to avoid slab reinforcement and to allow for field drilling bolt hole in web of existing beam for bracket assembly attachment.

Cored slab drains shall be placed vertically.

For details of plugging existing curb outlets, see Sheet No. 2.

Notes for Steel Drain:

Slab drains shall be fabricated from 1/4-inch structural steel tubing ASTM A500 or A501.

The drains shall be galvanized in accordance with ASTM A123.

Drains shall be inserted through slab such that damage to galvanized coating is minimized.

Notes for FRP Drain:

Drains shall be machine filament-wound thermosetting resin tubing meeting the requirements of ASTM D2996 with the following exceptions:

Minimum reinforced wall thickness shall be 1/4 inch.

The resin used shall be ultraviolet (UV) resistant and/or have UV inhibitors mixed throughout. Drains may have an exterior coating for additional UV resistance. Care shall be taken to avoid damage to exterior coating during installation.

The color of the slab drain shall be gray (Federal Standard 26373). The color shall be uniform throughout the resin and any coating used.

The combination of materials used in the manufacture of the drains shall be tested for UV resistance in accordance with ASTM D4329 Cycle A. The representative material shall withstand at least 500 hours of testing with only minor discoloration and without any physical deterioration. The contractor shall furnish the results of the required ultraviolet testing prior to acceptance of the slab drains.

At the contractor's option, drains may be field cut. The method of cutting FRP slab drains shall be as recommended by the manufacturer to ensure a smooth, chip-free cut.

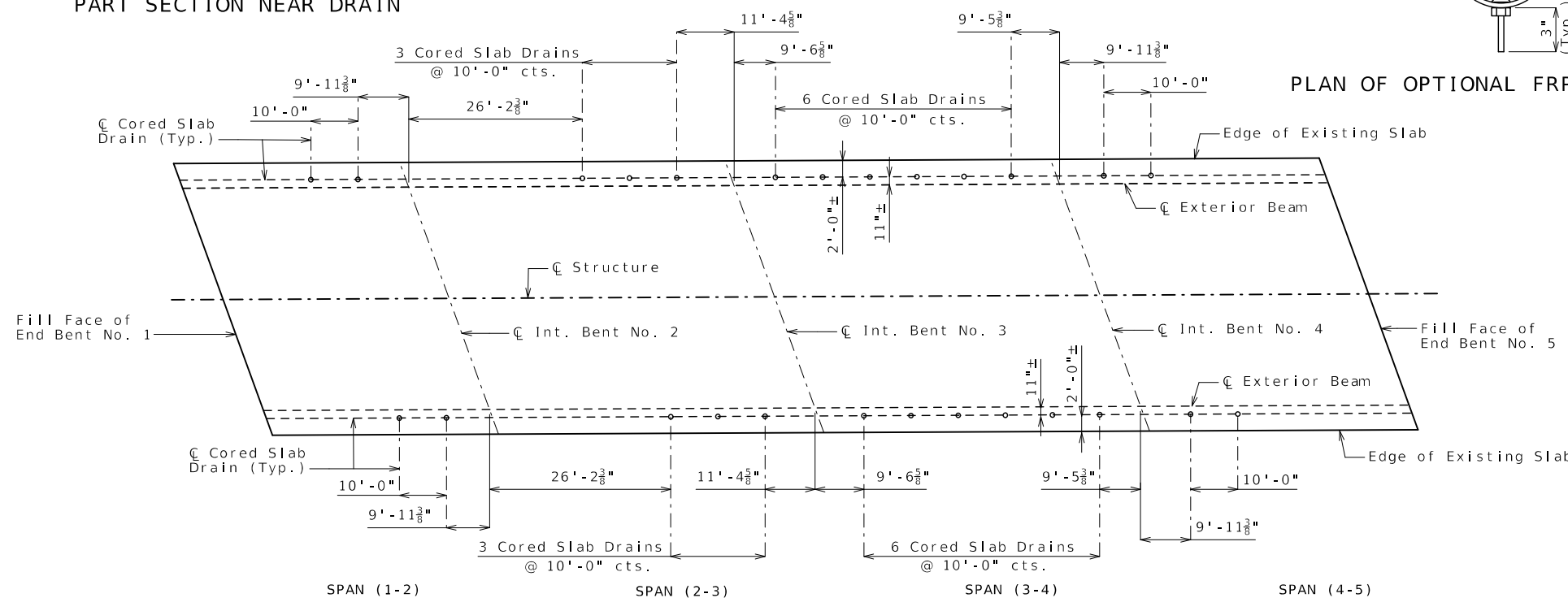

PART PLAN SHOWING CORED SLAB DRAIN LOCATIONS

CORED SLAB DRAINS

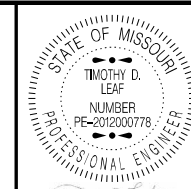

DATE PREPARED
9/25/2024

ROUTE 1-29
STATE MO
DISTRICT BR
SHEET NO. 3

COUNTY ANDREW
JOB NO. J113262
CONTRACT ID.

PROJECT NO.
BRIDGE NO. A12902

DATE	DESCRIPTION

MISSOURI HIGHWAYS AND TRANSPORTATION COMMISSION
MoDOT
105 WEST CAPITOL
JEFFERSON CITY, MO 65102
1-888-ASK-MODOT (1-888-275-6636)

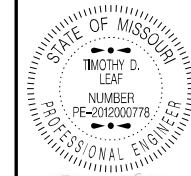

DATE PREPARED
9/25/2024

ROUTE
1-29

STATE
MO

DISTRICT
BR

SHEET NO.
4

COUNTY
ANDREW

JOB NO.
J113262

CONTRACT ID.

PROJECT NO.

BRIDGE NO.
A12902

DESCRIPTION

DATE

MISSOURI HIGHWAYS AND TRANSPORTATION COMMISSION

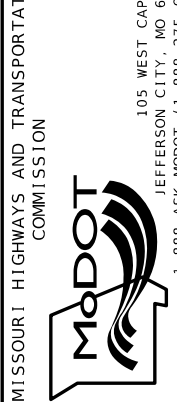

105 WEST CAPITOL
JEFFERSON CITY, MO 65102
1-888-ASK-MODOT (1-888-275-6636)

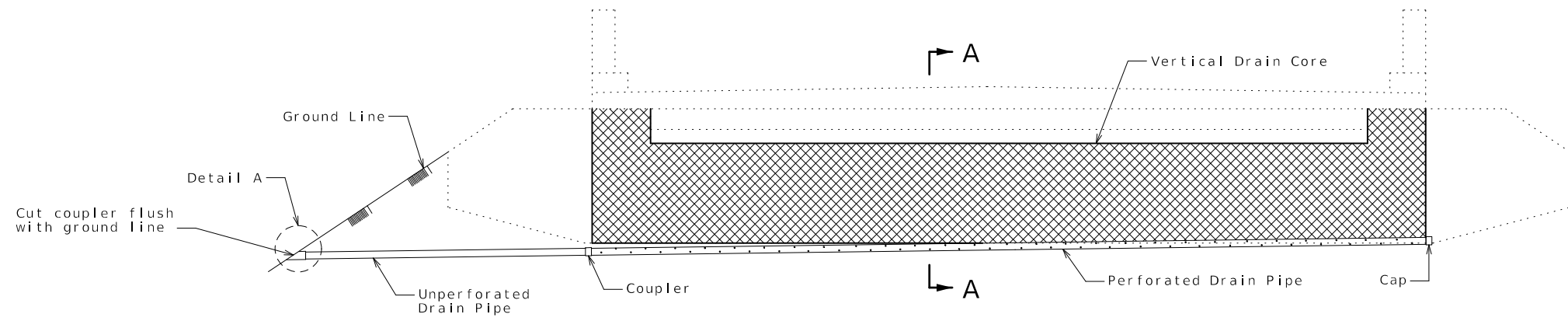

ELEVATION OF END BENT

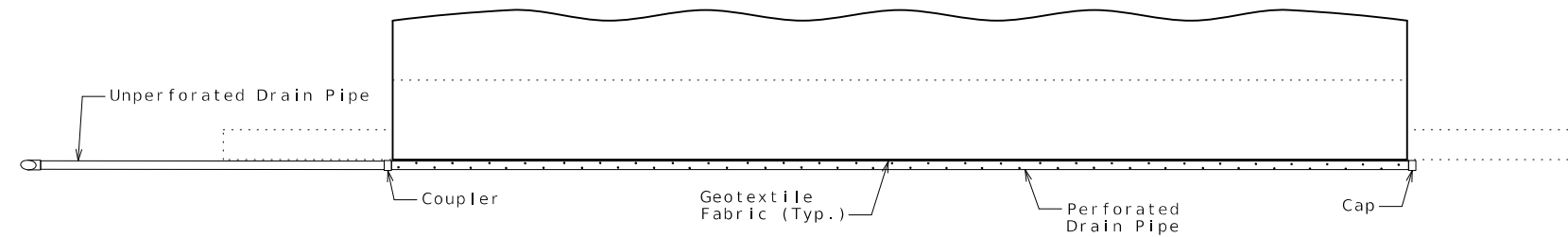

PLAN OF END BENT

(Approach Notch not shown for clarity)

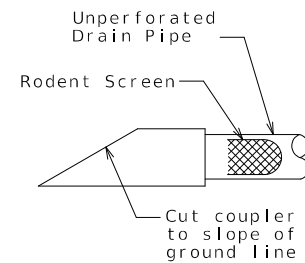

DETAIL A

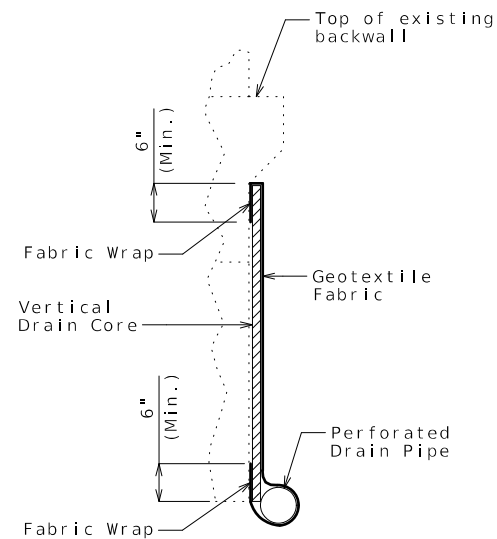

PART SECTION A-A

General Notes:

All drain pipe shall be sloped 1 to 2 percent.

Drain pipe may be either 6-inch diameter corrugated metallic-coated steel pipe underdrain, 4-inch diameter corrugated polyvinyl chloride (PVC) drain pipe, or 4-inch diameter corrugated polyethylene (PE) drain pipe.

Drain pipe shall be placed at fill face of end bent and inside face of wings. The pipe shall slope to lowest grade of ground line, also missing the lower beam of end bent by a minimum of 1 1/2 inches.

Perforated pipe shall be placed at fill face side and inside face of wings at the bottom of end bent and plain pipe shall be used where the vertical drain ends to the exit at ground line.

VERTICAL DRAIN AT END BENTS

(Squared end bent shown, skewed end bent similar)

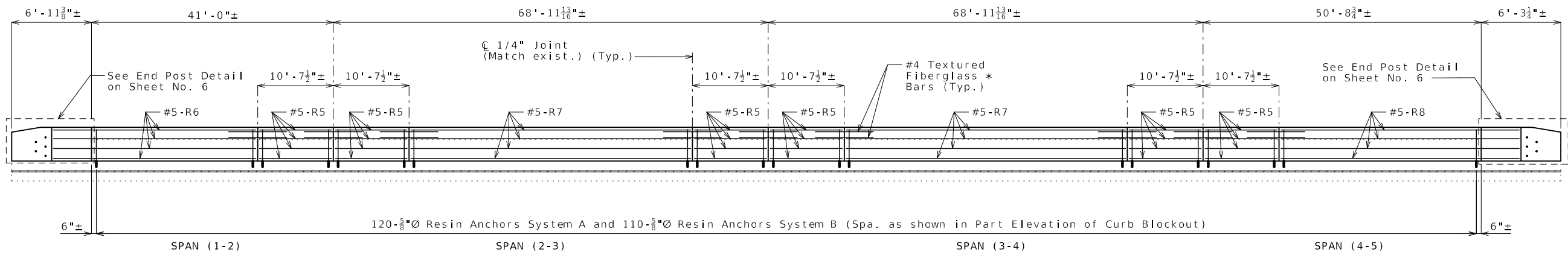

ELEVATION OF LEFT CURB BLOCKOUT
(Right curb blockout similar)

Longitudinal dimensions are along grade and are taken at top outside edge of parapet.

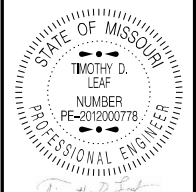

DATE PREPARED 9/25/2024	
ROUTE 1-29	STATE MO
DISTRICT BR	SHEET NO. 5
COUNTY ANDREW	
JOB NO. J113262	
CONTRACT ID.	
PROJECT NO.	
BRIDGE NO. A12902	

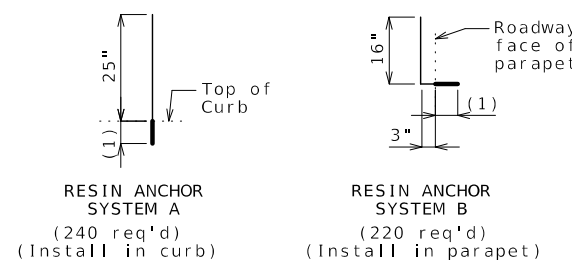

DETAILS OF RESIN ANCHORS

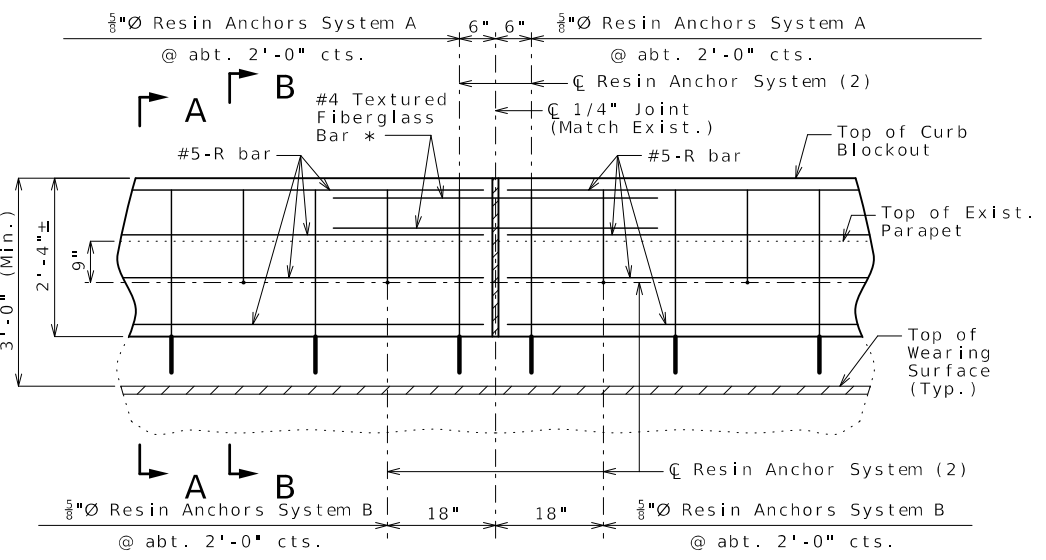
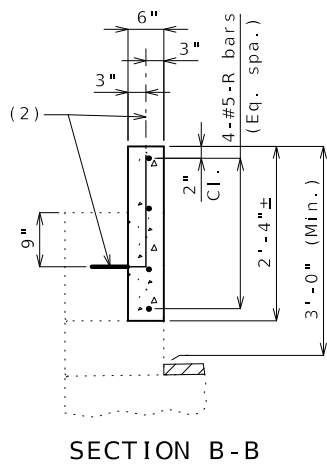
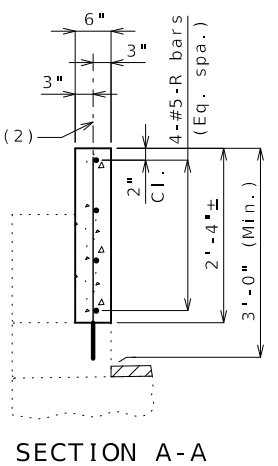
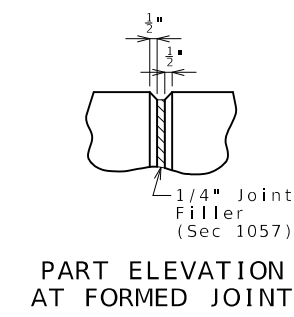

CURB BLOCKOUT
Sheet No. 5 of 8

- Notes:**
- * Slip Formed option only
 - Concrete in curb blockout shall be Class B-1 with $f'c = 4000$ psi.
 - Measurement of curb blockout is to the nearest linear foot, measured at the top outside edge of parapet from end of wing to end of wing.
 - All exposed edges of curb blockout shall have either a 1/2-inch radius or 3/8-inch bevel, unless otherwise noted.
 - Payment for concrete, reinforcement, resin anchor systems and any other work incidental to the curb blockout, complete in place, will be considered completely covered by the contract unit price for Curb Blockout per linear foot.
 - Cost of any concrete curb or parapet repair will be considered completely covered by the contract unit price for Curb Blockout.
 - All curb blockout reinforcement shall be epoxy coated.
 - (2) Shift resin anchors where necessary to clear existing anchor bolts for bridge rail, miss curb outlets (if present) and clear existing reinforcement.
 - Use a minimum lap of 3'-1" for #5 horizontal curb blockout bars.
 - Concrete traffic barrier delineators shall be placed on top of curb blockout similarly as shown on Missouri Standard Plans 617.10 and in accordance with Sec 617. Delineators on bridges with two-lane, two-way traffic shall have retroreflective sheeting on both sides. Concrete traffic barrier delineators will be considered completely covered by the contract unit price for Curb Blockout.
 - The contractor shall use one of the qualified resin anchor systems in accordance with Sec 1039.
 - The minimum embedment depth in concrete with $f'c = 4,000$ psi for the resin anchor system shall be that required to meet the minimum ultimate pullout strength in accordance with Sec 1039 but shall not be less than 5 inches.
 - An epoxy coated #5 Grade 60 reinforcing bar shall be substituted for the 5/8" \varnothing threaded rod.

DATE	DESCRIPTION

MISSOURI HIGHWAYS AND TRANSPORTATION COMMISSION

105 WEST CAPITOL JEFFERSON CITY, MO 65102
1-888-ASK-MODOT (1-888-275-6636)

Detailed Mar. 2023
Checked Nov. 2023

Note: This drawing is not to scale. Follow dimensions.



DATE PREPARED
9/25/2024

ROUTE STATE
1-29 MO

DISTRICT SHEET NO.
BR 6

COUNTY
ANDREW

JOB NO.
J113262

CONTRACT ID.

PROJECT NO.

BRIDGE NO.
A12902

DESCRIPTION	DATE

MISSOURI HIGHWAYS AND TRANSPORTATION COMMISSION

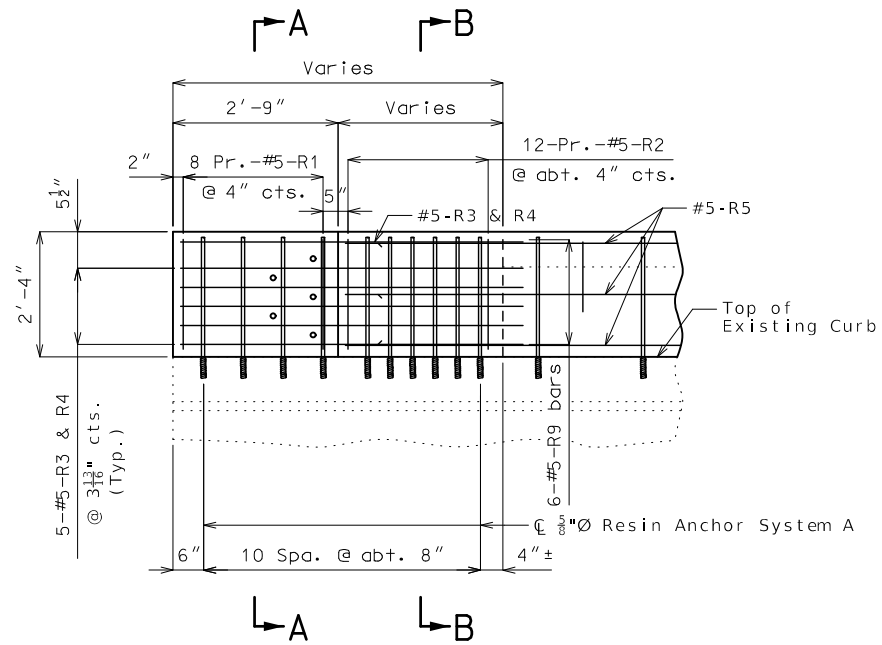
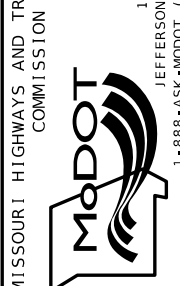

ELEVATION SHOWING END POST REINFORCEMENT

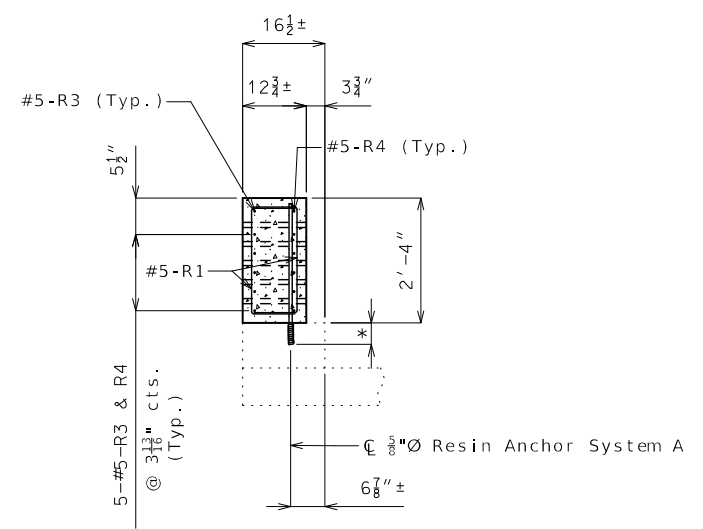

SECTION A-A

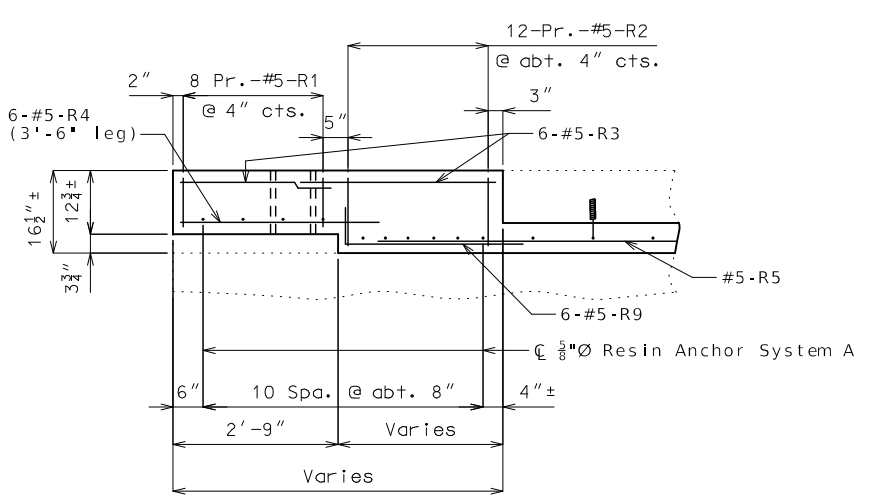

PLAN SHOWING END POST REINFORCEMENT

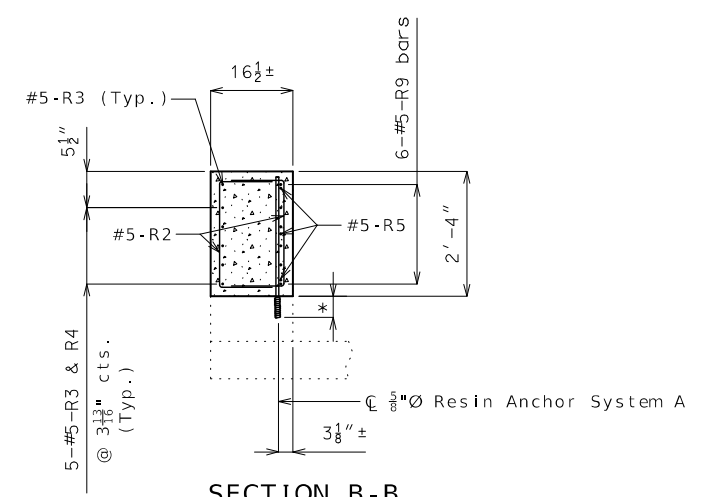

SECTION B-B

* Manufacturer's recommended embedment length (5" min.)

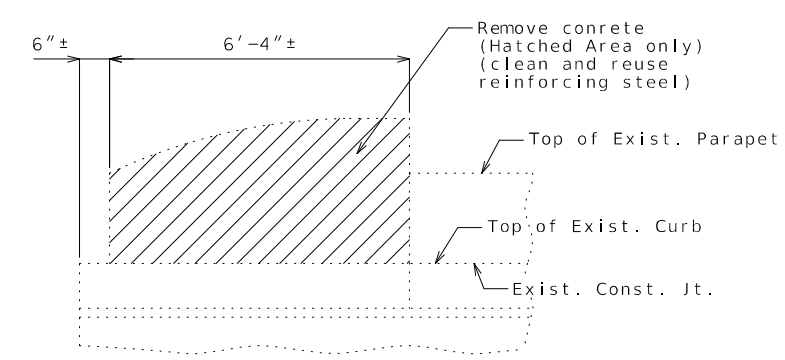

PART ELEVATION SHOWING END POST CONCRETE REMOVAL

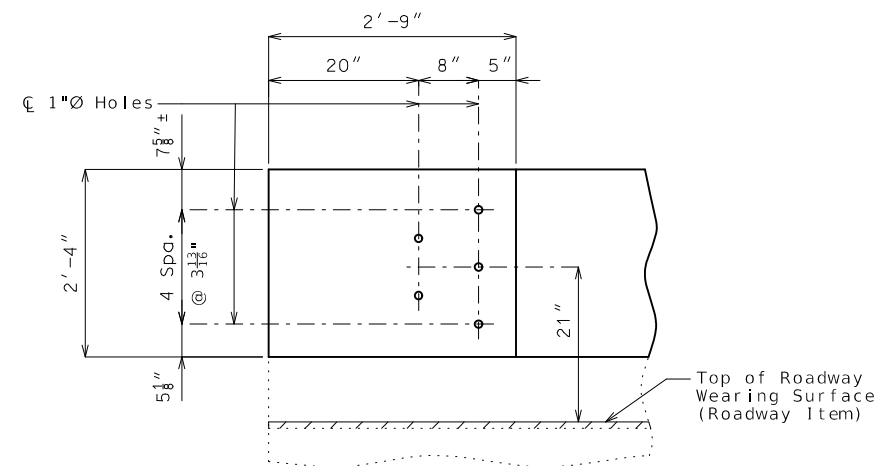

DETAILS OF GUARD RAIL ATTACHMENT

DETAILS OF END POST AT END BENTS

Notes:

- All exposed edges of curb blockout shall have 1/2" radius or 3/8" bevel unless otherwise shown.
- Use a minimum lap of 3'-1" for #5 horizontal curb blockout bars.
- Payment for concrete, reinforcing steel, resin anchor systems, and any other work incidental to the curb blockout, complete in place, will be included in the contract unit price for Curb Blockout per linear foot.
- Cost of any concrete curb or parapet repair will be included in the contract unit price for Curb Blockout.
- All reinforcement shall be epoxy coated.
- For Details and notes of Resin Anchor Systems, see Sheet No. 5.
- If there are additional R2 bars remaining after placing the bars based on the spacings shown, contractor may elect to not install the extra R2 bars, per the approval of the engineer.

Note:
Cost of removing existing end posts will be considered completely covered by the contract unit price for Curb Blockout.

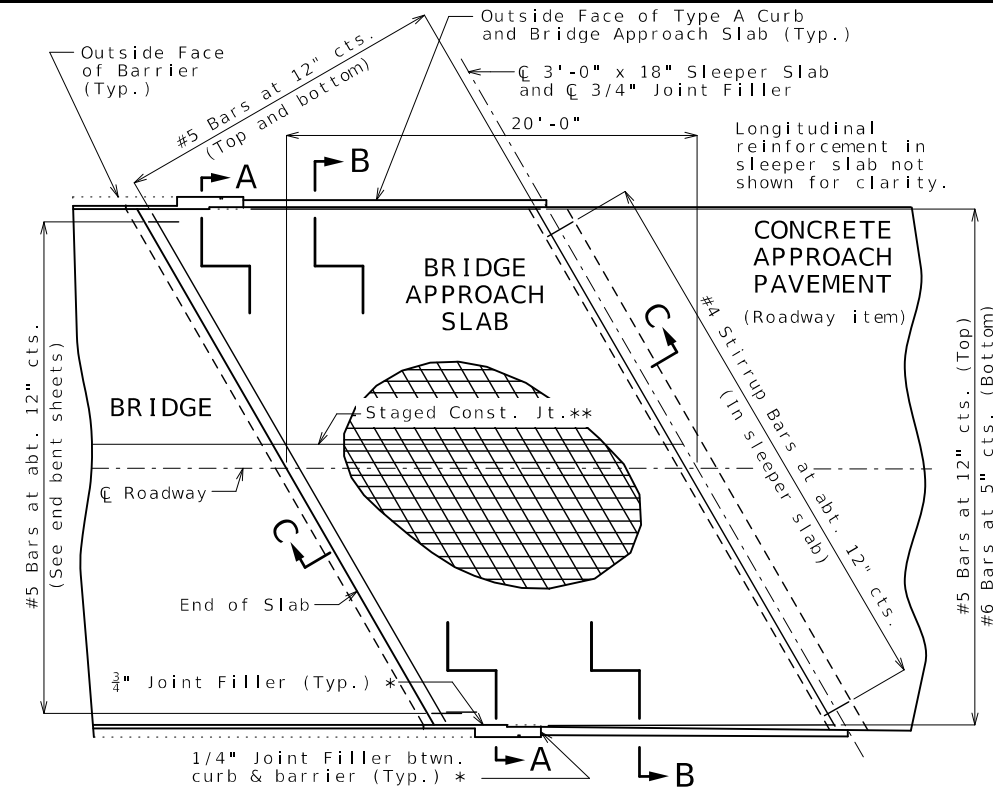

PART PLAN SHOWING REINFORCEMENT

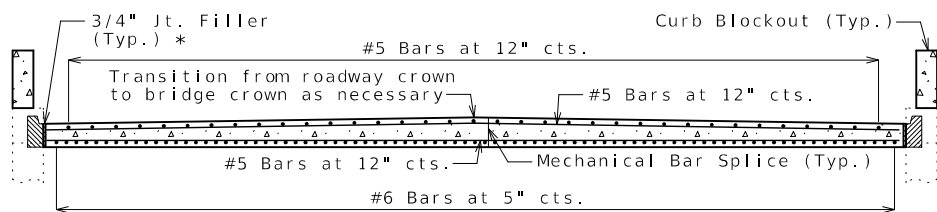

SECTION A-A

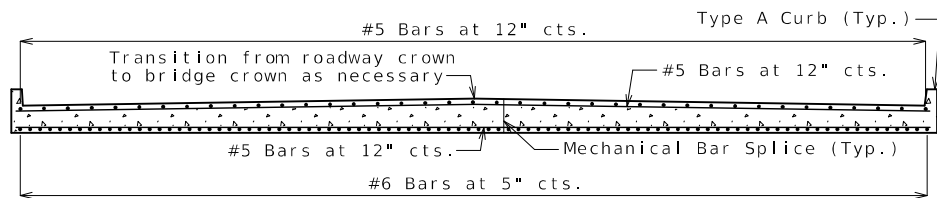

SECTION B-B

With the approval of the engineer, the contractor may crown the bottom of the approach slab to match the crown of the roadway surface.

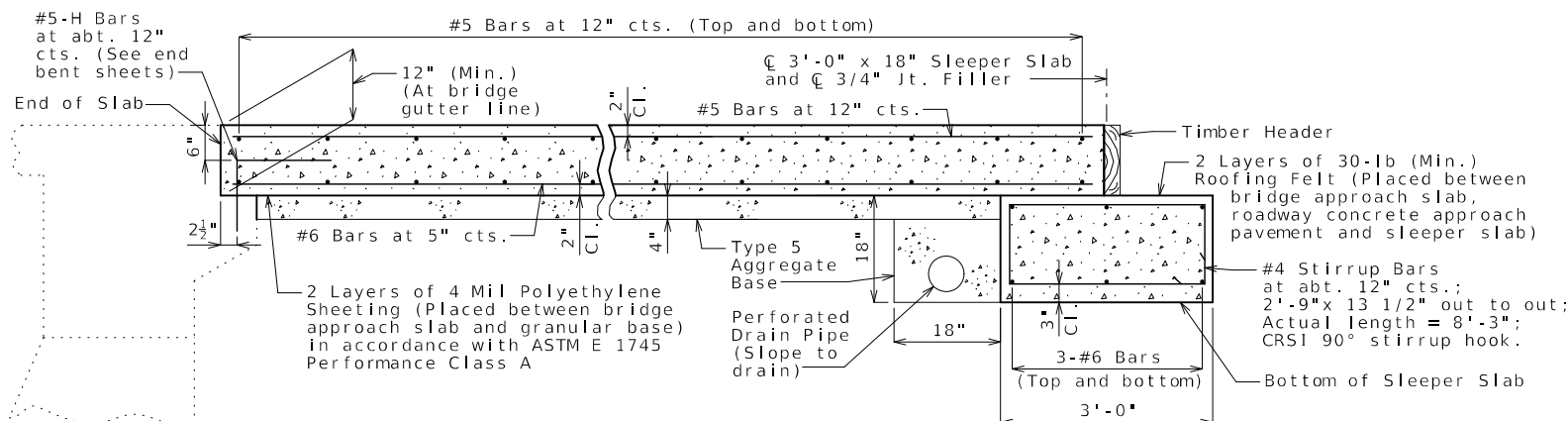

SECTION C-C

BRIDGE APPROACH SLAB (MAJOR)

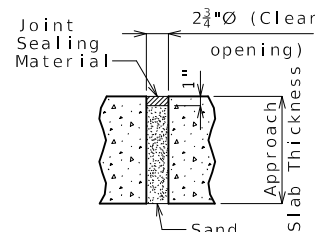

UNDERSEAL ACCESS HOLE DETAIL

(If required)

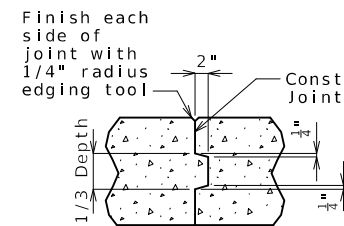

CONSTRUCTION JOINT DETAIL

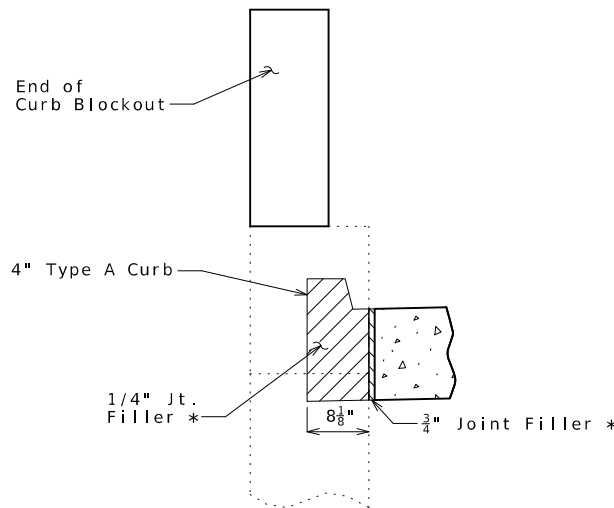

SECTION BETWEEN CURB AND BARRIER

General Notes:

All concrete for the bridge approach slab and sleeper slab shall be in accordance with Sec 503 ($f'c = 4,000$ psi).

The reinforcing steel in the bridge approach slab and the sleeper slab shall be epoxy coated Grade 60 with $f_y = 60,000$ psi.

Drain pipe may be either 6" diameter corrugated metallic-coated pipe underdrain, 4" diameter corrugated polyvinyl chloride (PVC) drain pipe, or 4" diameter corrugated polyethylene (PE) drain pipe.

Minimum clearance to reinforcing steel shall be 1 1/2", unless otherwise shown.

The reinforcing steel in the bridge approach slab and the sleeper slab shall be continuous. The transverse reinforcing steel may be made continuous by providing a minimum lap splice of 29 inches for #5 bars and 44 inches for #6 bars, or by mechanical bar splice.

Mechanical bar splices shall be in accordance with Sec. 710. (Estimated 70 splices per slab)

All joint filler shall be in accordance with Sec 1057 for preformed fiber expansion joint filler except as noted.

The contractor shall pour and satisfactorily finish the bridge slab before placing the bridge approach slab.

Longitudinal construction joints in approach slab and sleeper slab shall be aligned with longitudinal construction joints in bridge slab.

For concrete approach pavement details, see roadway plans.

See Missouri Standard Plan 609.00 for details of Type A curb.

Payment for furnishing all materials, labor and excavation necessary to construct the approach slab, including the timber header, sleeper slab, underdrain, Type 5 aggregate base, joint filler and all other appurtenances and incidental work as shown on this sheet, complete in place, will be considered completely covered by the contract unit price for Bridge Approach Slab (Major) per square yard.

*Seal joint between vertical face of approach slab and wing with sealant in accordance with Sec 717 for silicone joint sealant for saw cut and formed joints.

**Location of construction joint is approximate. See roadway plans for locations for staged traffic.

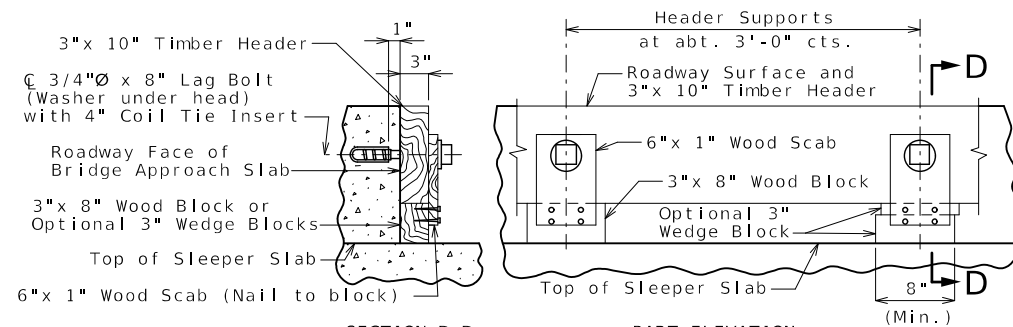

SECTION D-D

PART ELEVATION

DETAILS OF TIMBER HEADER

Remove timber header when concrete pavement is placed.

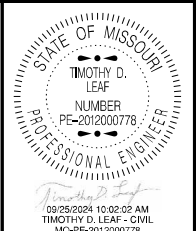

DATE PREPARED	
9/25/2024	STATE
ROUTE	MO
DISTRICT	SHEET NO.
BR	7
COUNTY	
ANDREW	
JOB NO.	
J113262	
CONTRACT ID.	
PROJECT NO.	
BRIDGE NO.	
A12902	

DATE	DESCRIPTION

MISSOURI HIGHWAYS AND TRANSPORTATION COMMISSION

105 WEST CAPITOL
JEFFERSON CITY, MO 65102
1-888-ASK-MODOT (1-888-275-6636)

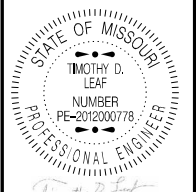
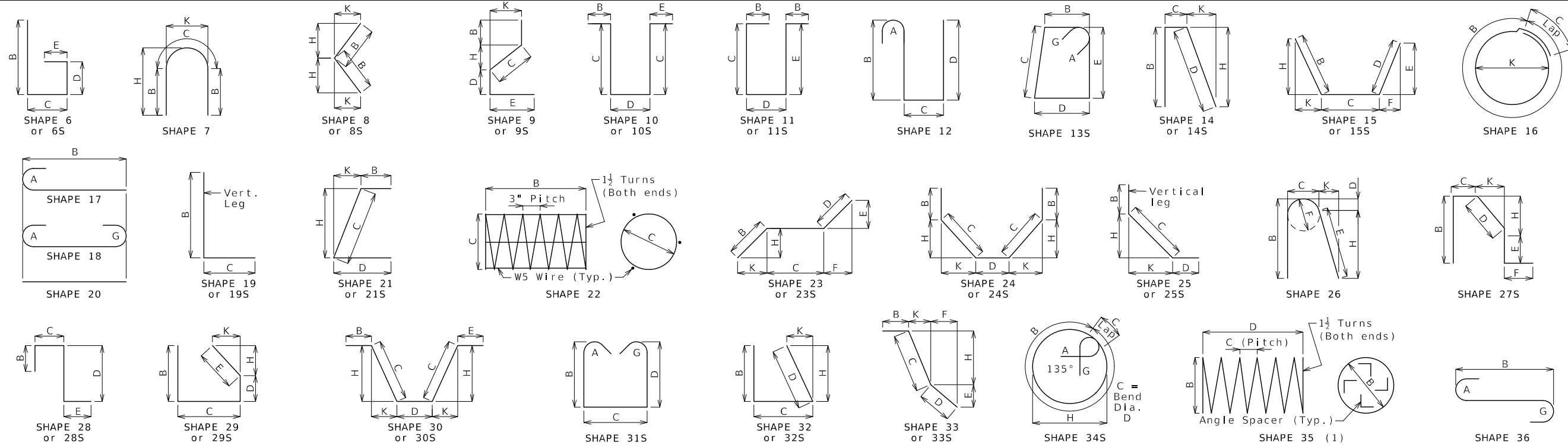

DATE PREPARED
9/25/2024

ROUTE
I - 29

DISTRICT
BR

COUNTY
ANDREW

JOB NO.
J113262

CONTRACT ID.

PROJECT NO.

BRIDGE NO.
A12902

DESCRIPTION	DATE

Finished Bend Diameters D and Hook Dimensions

Standard Pin Bend Shapes

Size	Case	D	A or G		J
			90°	180°	
#4	1	3"	8"	6"	4"
#5	1	3 3/8"	10"	7"	5"
#6	1	4 1/2"	12"	8 1/4"	6"
#7	2	5 1/4"	14"	9 3/4"	7"
	3	7"	15"	11 1/2"	8 3/4"
#8	2	6"	16"	11"	8"
	3	8"	17"	13 1/4"	10"
#9	1	9 1/2"	19 1/2"	15 1/2"	11 3/4"
#10	1	10 3/4"	22"	17 1/2"	13 1/4"
#11	1	12"	24 1/2"	19 1/2"	14 3/8"
#14	1	18 1/4"	31 1/4"	27 1/2"	21 5/8"
#18	1	24"	41 1/2"	36 1/4"	28 1/2"

Stirrup Pin Bend Shapes (S)

Size	Case	D	A or G		H	J
			90°	135°		
#4	2	2"	4 1/2"	4 1/2"	5"	2 3/8"
	3	3"	5"	5 1/4"	6"	3"
#5	2	2 3/4"	5 3/4"	5 3/4"	5 3/4"	3 3/8"
	3	3 3/4"	6 1/4"	6 1/2"	7"	3 3/8"
#6	1	4 1/2"	12"	7 3/4"	8 1/4"	4 3/8"

Applicable for all grades of steel.
Case 1 applies to all reinforcement. Case 2 applies to all reinforcement except for galvanized bars. Case 3 applies to galvanized bars only.

Nominal lengths are based on out to out dimensions shown in bending diagrams and are listed to the nearest inch for fabricator's use. Actual lengths are measured along centerline bar to the nearest inch. Weights are based on actual lengths.

All bars shall be Grade 60.

Codes: C = Required coatings, where E = Epoxy Coated and G = Galvanized.
SH = Required shape, see bending diagrams.

V = Sets of varied bars and number of bars of each length. Bar dimensions vary in equal increments between dimensions shown on this line and the following line and the actual length dimension shown on this line and the following line vary by the specified increment.

All dimensions are out to out. (1) Shall be a deformed or plain spiral bar or wire.

Shapes ending with an S shall be bent in accordance with stirrup pin bend shapes. Four angle or channel spacers are required for each column spiral. Spacers are to be placed on inside of spirals. Length and weight of column spirals do not include splices or spacers.

Unless otherwise noted, finished bending diameter D is the same for all bends of a shape.

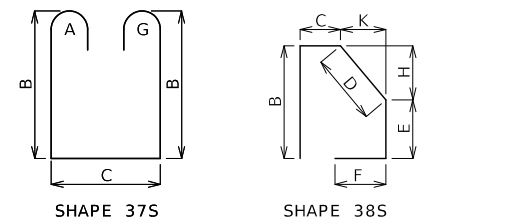

BENDING DIAGRAMS

Reinforcing Steel Totals (Pounds)

Size	Substructure		Superstructure			Entire Bridge	
	Plain	Epoxy	Slab	Barrier	Slip Form	Plain	Epoxy
W5	0	0	0	0	0	0	0
4	0	0	0	0	0	0	0
5	0	0	0	3,187	0	0	3,187
6	0	0	0	0	0	0	0
7	0	0	0	0	0	0	0
By Type	0	0	0	3,187	0	0	3,187

All superstructure reinforcing steel shall be epoxy coated unless otherwise specified.

Bill of Reinforcing Steel

No. Req.	Size/Mark	Location	Dimensions							Nom. Length	Actual Length	Weight		
			Codes	B	C	D	E	F	H				K	
		Barrier												
		Curb Blockout												
64	5 R1	BLOCKOUT	E 10S			9.75	21.00					3 5	3 2	211
96	5 R2	BLOCKOUT	E 10S			13.50	21.00					4 0	3 9	375
48	5 R3	BLOCKOUT	E 20		4 10.00							4 10	4 10	242
24	5 R4	BLOCKOUT	E 28S			2 9.00	3.75	3 1.00				6 2	5 11	148
48	5 R5	BLOCKOUT	E 20		10 4.00							10 4	10 4	517
8	5 R6	BLOCKOUT	E 20		47 5.00							47 5	47 5	396
16	5 R7	BLOCKOUT	E 20		47 5.00							47 5	47 5	791
8	5 R8	BLOCKOUT	E 20		45 3.00							45 3	45 3	378
24	5 R9	BLOCKOUT	E 19S		4 6.00	9.00						5 3	5 2	129

BENDING DIAGRAMS AND REINFORCING STEEL TOTALS

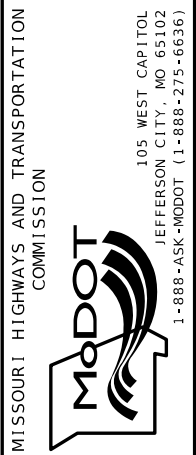

U.I.P. AND REHABILITATE EXISTING (46'-69'-69'-55') CONTINUOUS COMPOSITE WIDE FLANGE BEAM SPANS
(SKEW: 20° R.A.)

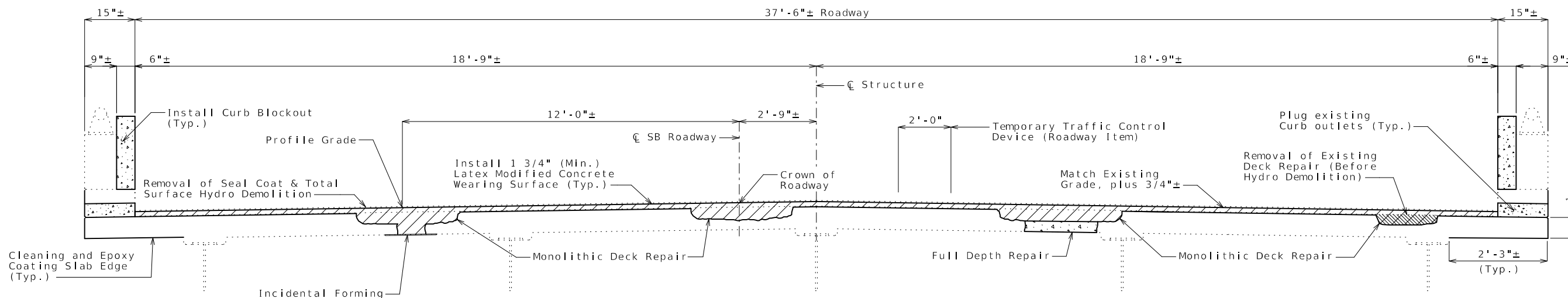

TYPICAL SECTION THRU EXISTING DECK

Note: For details of repairs to deck concrete, see Sheet No. 2.

Estimated Quantities		
Item		Total
Total Surface Hydro Demolition	sq. yard	1013
Removal of Seal Coat or Polymer Wearing Surface	sq. foot	9116
Removal of Existing Deck Repair	sq. foot	100
Bridge Approach Slab (Major)	sq. yard	175
* Supplementary Wearing Surface Material	cu. yard	12
Latex Modified Concrete Wearing Surface	sq. yard	1013
Diamond Grinding	sq. yard	1013
Curb Blockout	linear foot	481
Full Depth Repair	sq. foot	500
Plugging Existing Curb Outlets	each	20
Protective Coating - Concrete Bents and Piers (Epoxy)	lump sum	1
Cleaning and Coating Existing Bearings	each	10
Cored Slab Drain	each	26

*Supplementary wearing surface material for monolithic deck repair will be paid for at the fixed unit price in accordance with Sec 109.

General Notes:

Design Specifications:
2002 AASHTO LFD (17th Ed.) Standard Specifications
Bridge Deck Rating = 5
Design Loading:
HS20-44 (1961 & New Construction)
Design Unit Stresses:

Class B-1 Concrete (Curb Blockout) f'c = 4,000 psi
Class B-2 Concrete (Full Depth Repair) f'c = 4,000 psi

Contractor can use either Class B-1 or Class B-2 concrete or Wearing Surface material for Slab Drain plugs, same material shall be used throughout.

Concrete Protective Coatings:
Protective Coating for Concrete Bents and Piers (Epoxy) shall be applied as shown on the bridge plans and in accordance with Sec 711.

Miscellaneous:
Roadway surfacing adjacent to bridge ends shall match new bridge wearing surface (Roadway Item).

All concrete repairs shall be in accordance with Sec 704, unless otherwise noted.

Outline of existing work is indicated by light dashed lines. Heavy lines indicate new work.

Contractor shall verify all dimensions in field before ordering new material.

In order to maintain grade and a minimum thickness of wearing surface as shown on plans it may be necessary to use additional quantities of wearing surface at various locations throughout the structure. The cost of furnishing and installing the wearing surface will be considered completely covered in the contract unit price, including all additional labor, materials or equipment for variations in thickness of wearing surface.

Traffic Handling:
Traffic to be maintained on structure during construction. See roadway plans for traffic control.

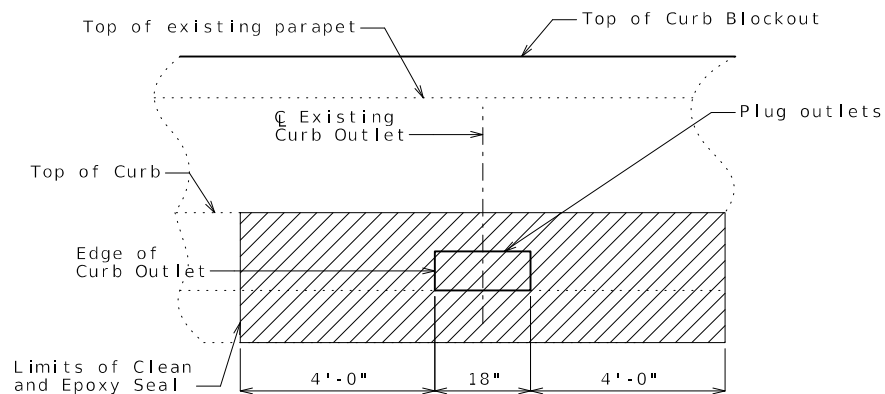

PART ELEVATION SHOWING CLEAN AND EPOXY SEAL AND PLUGGING OF CURB OUTLETS

Notes:

New 1 3/4" Latex Modified Concrete Overlay not shown for clarity.

Cost of labor and materials required to plug existing curb outlets will be considered completely covered by the contract unit price for Plugging Existing Curb Outlets, per each.

Estimated material required to fill all curb outlets is 0.4 cubic yards.

TYPICAL SECTION THRU EDGE OF SLAB SHOWING CLEAN AND EPOXY SEAL

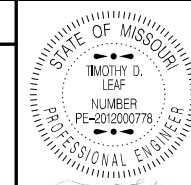
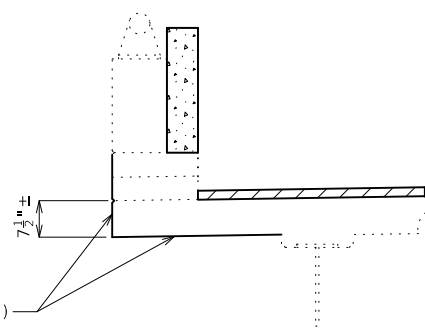

DATE PREPARED
9/25/2024

ROUTE 1-29 STATE MO

DISTRICT BR SHEET NO. 1

COUNTY ANDREW

JOB NO. J113262

CONTRACT ID.

PROJECT NO.

BRIDGE NO. A12903

DESCRIPTION

DATE

MISSOURI HIGHWAYS AND TRANSPORTATION COMMISSION



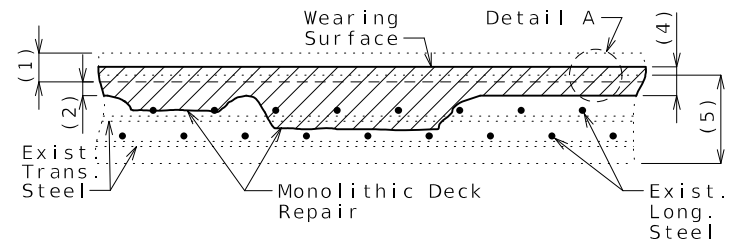

MONOLITHIC DECK REPAIR

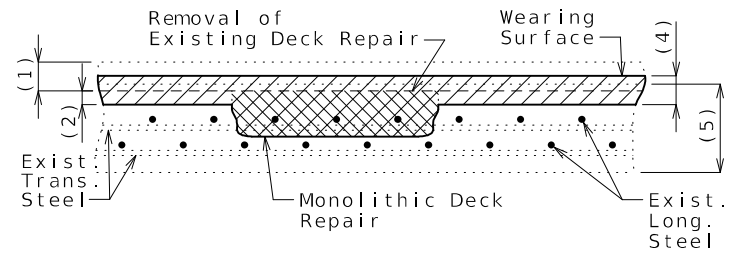

REMOVAL OF EXISTING DECK REPAIR BEFORE HYDRO DEMOLITION

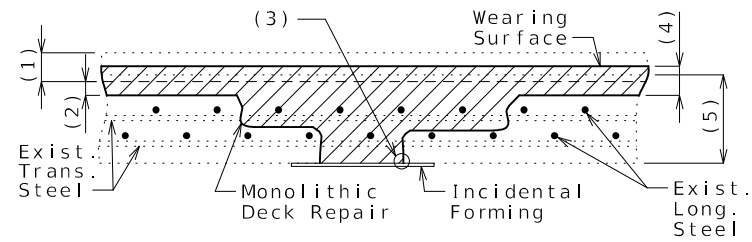

MONOLITHIC DECK REPAIR REQUIRING INCIDENTAL FORMING

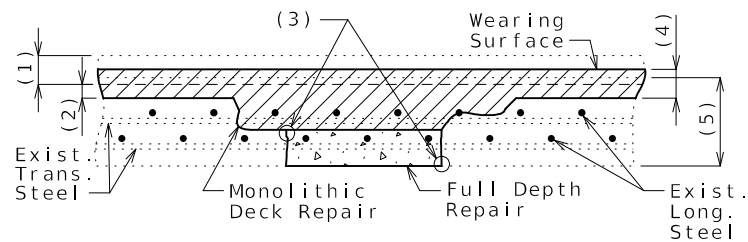

MONOLITHIC DECK REPAIR REQUIRING FULL DEPTH REPAIR

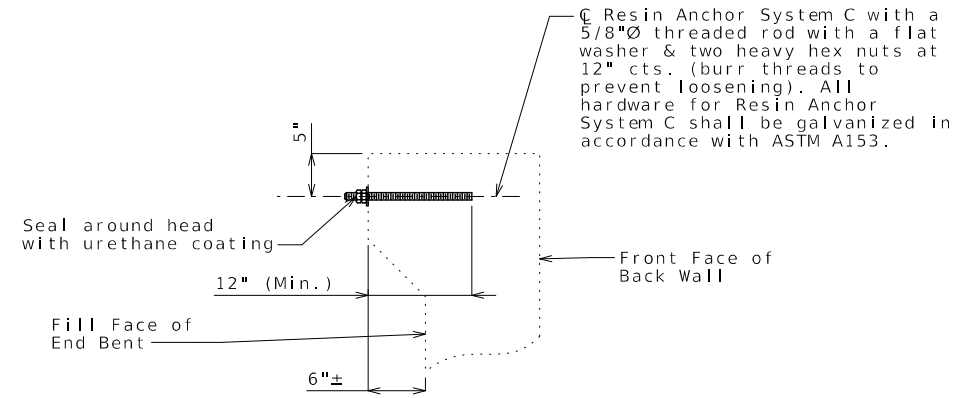
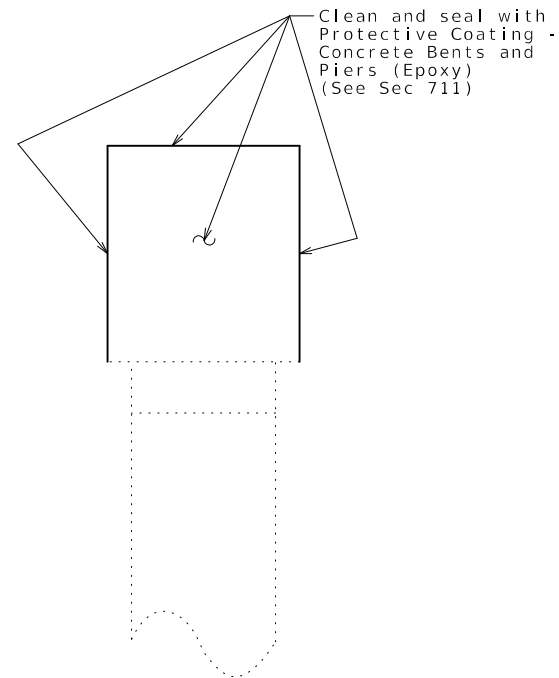

DETAILS OF RESIN ANCHOR SYSTEM AT END BENTS NO. 1 & 4

System C
(54 total req'd.)

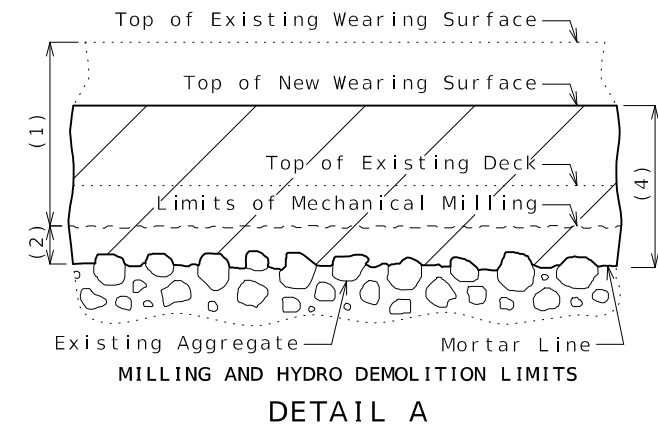

**MILLING AND HYDRO DEMOLITION LIMITS
DETAIL A**

PART SECTION THRU EXISTING BEAM SHOWING PROTECTIVE COATING LIMITS (INT. BENTS NO. 2, 3, & 4)

Note:
The cost of applying protective coating to Intermediate Bents No. 2, 3, & 4 will be covered by the contract lump sum price for Protective Coating - Concrete Bents & Piers (Epoxy).

- (1) Removal of existing wearing surface plus 1/2" thickness (min.) of existing bridge deck.
- (2) 1/2" minimum total surface hydro demolition of sound concrete, measured to mortar line
- (3) 1" vertical side shall be established outside the deteriorated area.
- (4) 1 3/4" minimum latex modified concrete wearing surface
- (5) Original depth of deck plus wearing surface

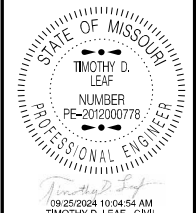

DATE PREPARED 9/25/2024	
ROUTE I-29	STATE MO
DISTRICT BR	SHEET NO. 2
COUNTY ANDREW	
JOB NO. J113262	
CONTRACT ID.	
PROJECT NO.	
BRIDGE NO. A12903	

DESCRIPTION	DATE

MISSOURI HIGHWAYS AND TRANSPORTATION COMMISSION

105 WEST CAPITOL
JEFFERSON CITY, MO 65102
1-888-ASK-MODOT (1-888-275-6636)

General Notes:

Contractor shall have the option to construct either steel or Fiberglass Reinforced Polymer (FRP) slab drains. All drains shall be of same type.

Slab drain bracket assembly shall be ASTM A709 Grade 36 steel.

The bracket assembly shall be galvanized in accordance with ASTM A123.

All bolts, hardened washers, lock washers and nuts shall be galvanized in accordance with ASTM A153.

Shop drawings will not be required for the slab drains and the bracket assembly.

Cost of cored slab drains, complete in place, will be considered completely covered by the contract unit price for Cored Slab Drains.

Holes for slab drains shall be cored. Percussion drilling will not be permitted.

Slab drain locations may be shifted the minimum extent necessary to avoid slab reinforcement and to allow for field drilling bolt hole in web of existing beam for bracket assembly attachment.

Cored slab drains shall be placed vertically.

For details of plugging existing curb outlets, see Sheet No. 2.

Notes for Steel Drain:

Slab drains may be fabricated from 1/4" structural steel pipe ASTM A500 or A501.

The drains shall be galvanized in accordance with ASTM A123.

Drains shall be inserted through slab such that damage to galvanized coating is minimized.

Notes for Optional FRP Drain:

Drains shall be machine filament-wound thermosetting resin pipe meeting the requirements of ASTM D2996 with the following exceptions:

Minimum reinforced wall thickness shall be 1/4 inch.

The resin used shall be ultraviolet (UV) resistant and/or have UV inhibitors mixed throughout. Drains may have an exterior coating for additional UV resistance. Care shall be taken to avoid damage to exterior coating during installation.

The color of the slab drain shall be Gray (Federal Standard #26373). The color shall be uniform throughout the resin and any coating used.

The combination of materials used in the manufacture of the drains shall be tested for UV resistance in accordance with ASTM D4329 Cycle A. The representative material shall withstand at least 500 hours of testing with only minor discoloration and without any physical deterioration. The contractor shall furnish the results of the required ultraviolet testing prior to acceptance of the slab drains.

At the contractor's option, drains may be field cut. The method of cutting FRP slab drain shall be as recommended by the manufacturer to ensure a smooth, chip free cut.

No additional payment will be made for this substitution.

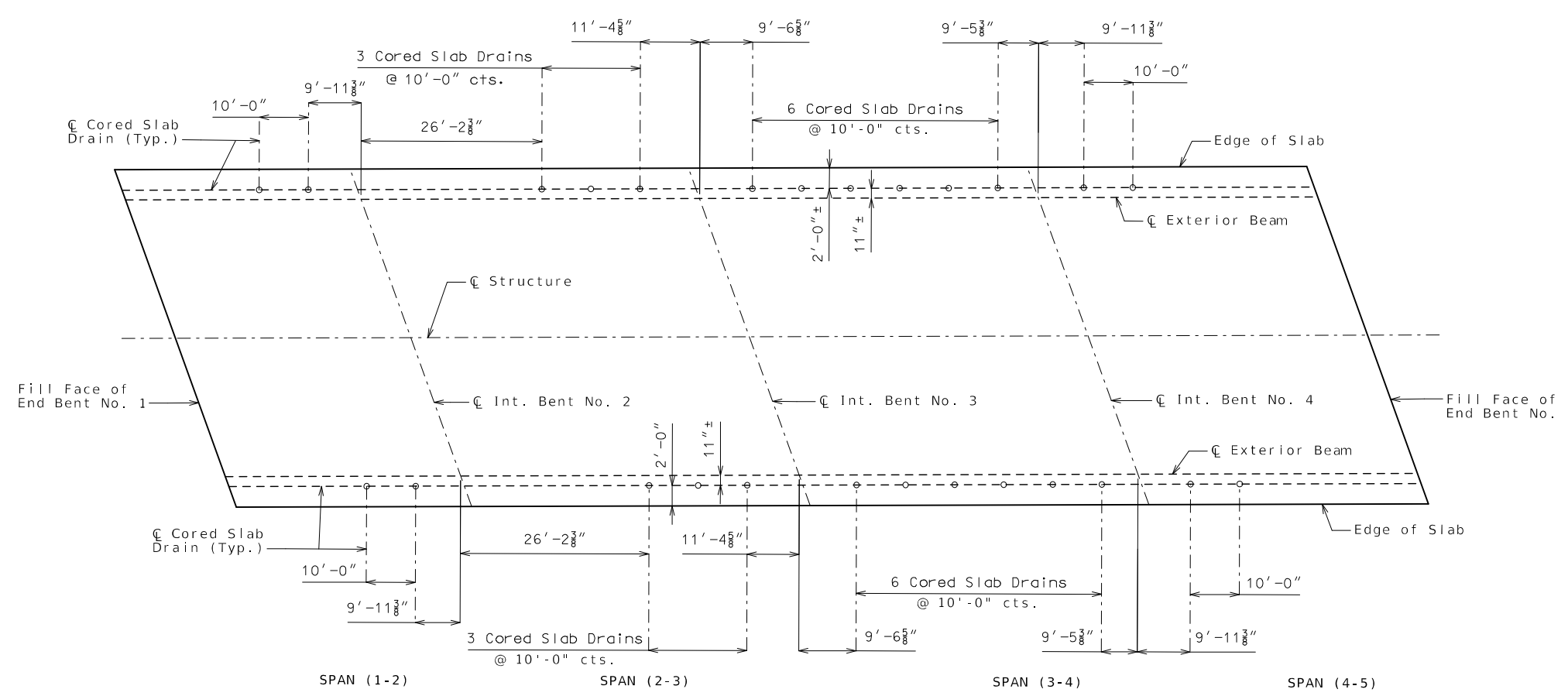

PART PLAN SHOWING CORED SLAB DRAIN LOCATIONS

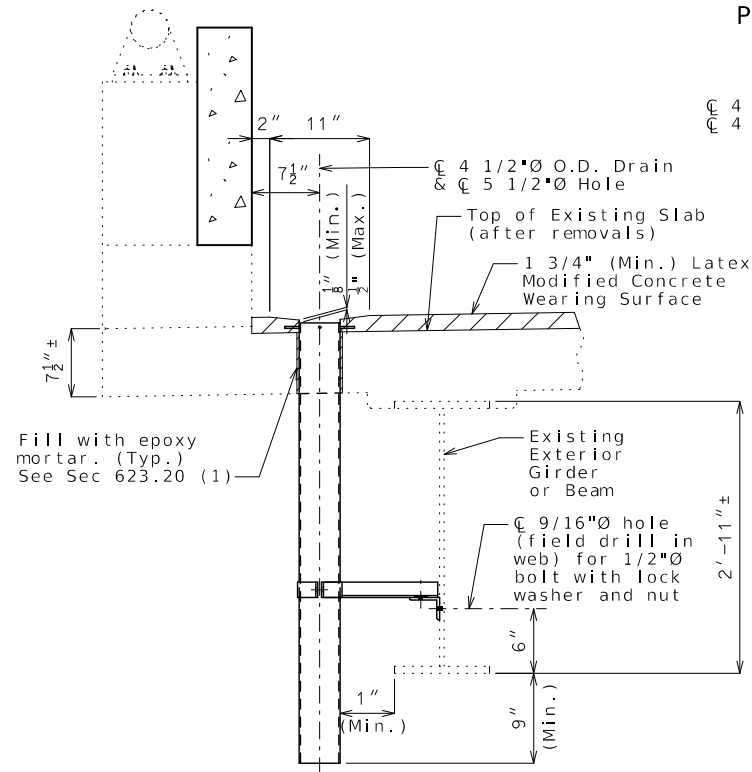

PART SECTION NEAR DRAIN

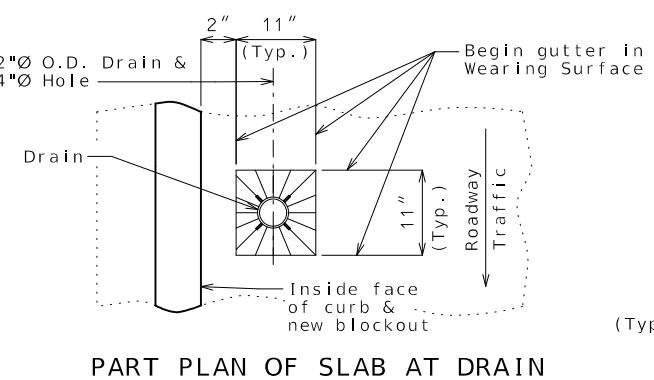

PART PLAN OF SLAB AT DRAIN

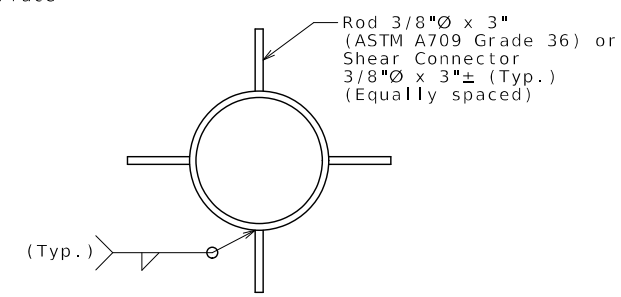

PLAN OF DRAIN

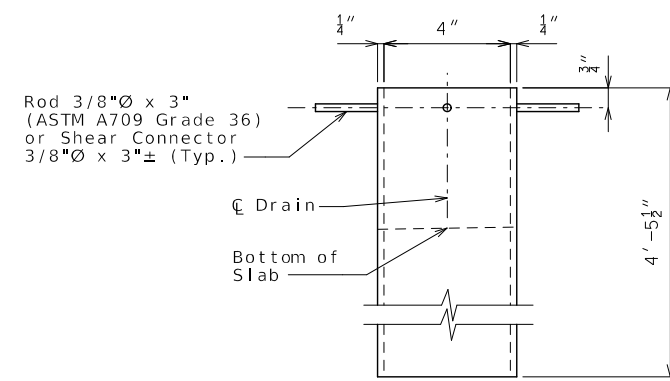

ELEVATION OF DRAIN

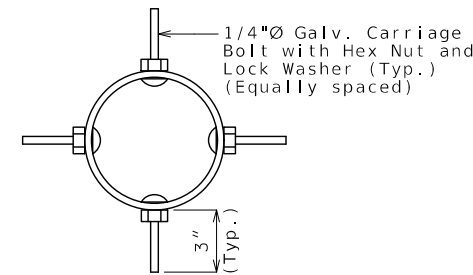

PLAN OF OPTIONAL FRP DRAIN

CORED SLAB DRAINS

(1) Use backer rod around drain @ bottom of slab and epoxy inject from the top.

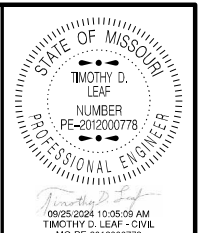

DATE PREPARED 9/25/2024	
ROUTE I-29	STATE MO
DISTRICT BR	SHEET NO. 3
COUNTY ANDREW	
JOB NO. J113262	
CONTRACT ID.	
PROJECT NO.	
BRIDGE NO. A12903	

DATE	DESCRIPTION

MISSOURI HIGHWAYS AND TRANSPORTATION COMMISSION

105 WEST CAPITOL
JEFFERSON CITY, MO 65102
1-888-ASK-MODOT (1-888-275-6636)

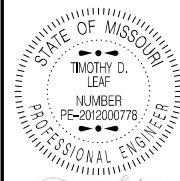

DATE PREPARED
9/25/2024

ROUTE STATE
I - 29 MO

DISTRICT SHEET NO.
BR 4

COUNTY
ANDREW

JOB NO.
J113262

CONTRACT ID.

PROJECT NO.

BRIDGE NO.
A12903

DATE	DESCRIPTION

MISSOURI HIGHWAYS AND TRANSPORTATION COMMISSION
 105 WEST CAPITOL JEFFERSON CITY, MO 65102
 1-888-ASK-MODOT (1-888-275-6636)

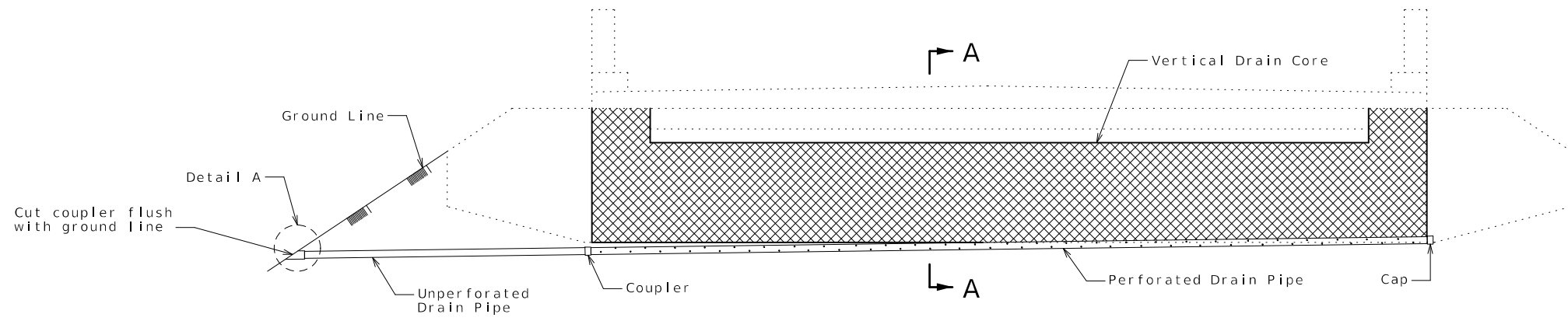

ELEVATION OF END BENT

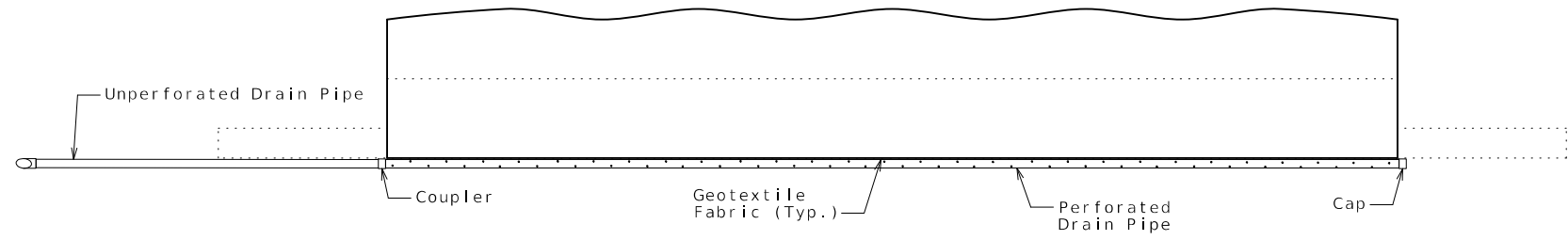

PLAN OF END BENT
(Approach Notch not shown for clarity)

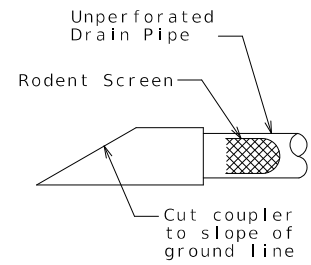

DETAIL A

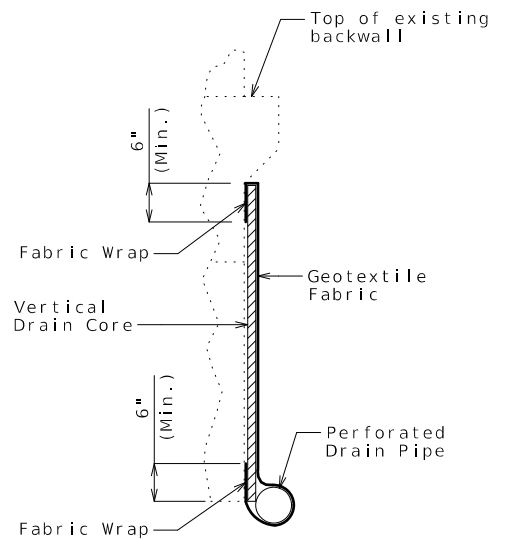

PART SECTION A-A

General Notes:

- All drain pipe shall be sloped 1 to 2 percent.
- Drain pipe may be either 6-inch diameter corrugated metallic-coated steel pipe underdrain, 4-inch diameter corrugated polyvinyl chloride (PVC) drain pipe, or 4-inch diameter corrugated polyethylene (PE) drain pipe.
- Drain pipe shall be placed at fill face of end bent and inside face of wings. The pipe shall slope to lowest grade of ground line, also missing the lower beam of end bent by a minimum of 1 1/2 inches.
- Perforated pipe shall be placed at fill face side and inside face of wings at the bottom of end bent and plain pipe shall be used where the vertical drain ends to the exit at ground line.

VERTICAL DRAIN AT END BENTS
(Squared end bent shown, skewed end bent similar)

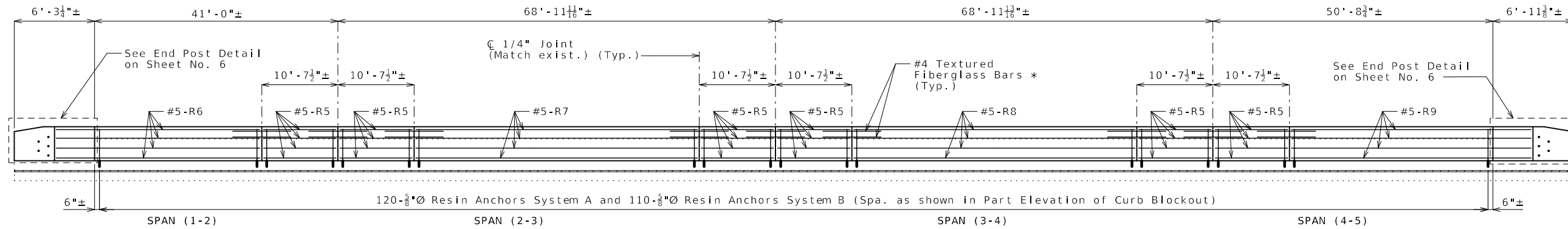

ELEVATION OF LEFT CURB BLOCKOUT

Longitudinal dimensions are along grade and are taken at top outside edge of parapet.

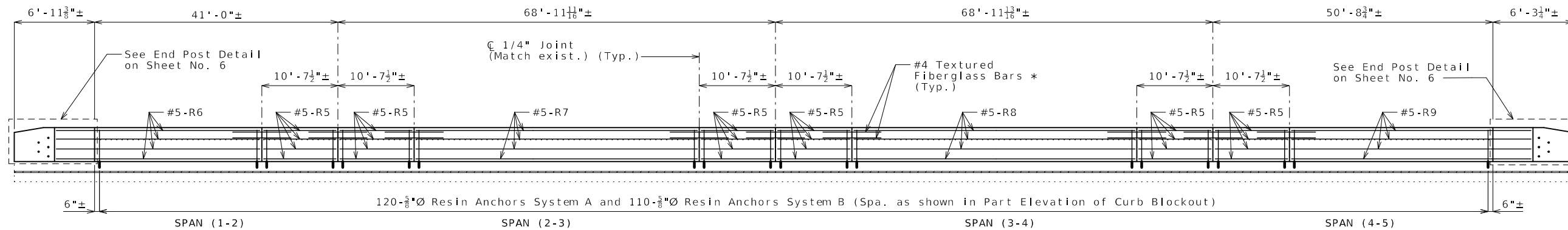

ELEVATION OF RIGHT CURB BLOCKOUT

Longitudinal dimensions are along grade and are taken at top outside edge of parapet.

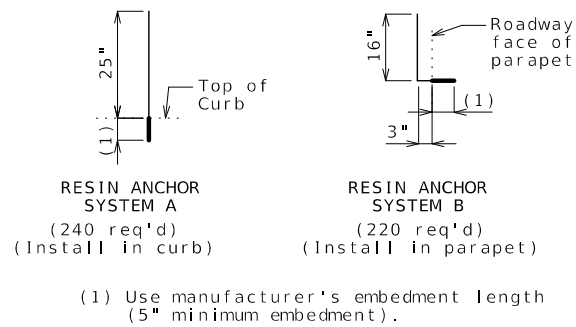

DETAILS OF RESIN ANCHORS

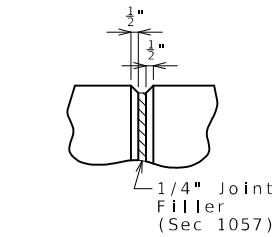

PART ELEVATION AT FORMED JOINT

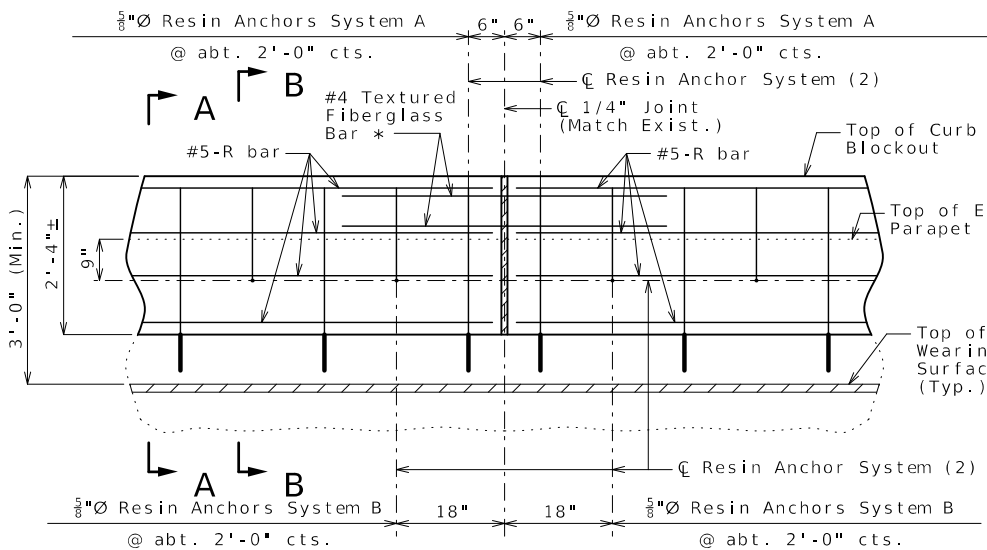

PART ELEVATION OF CURB BLOCKOUT

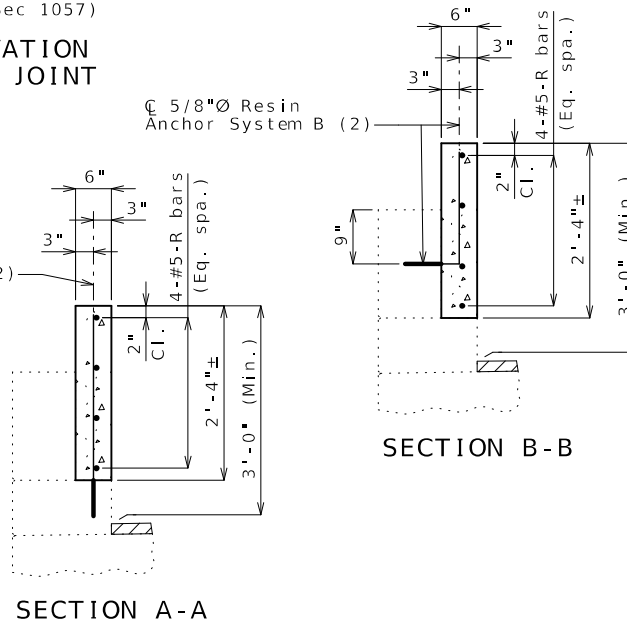

CURB BLOCKOUT

Sheet No. 5 of 8

Notes:

* Slip Formed option only

Conventional forming or slip forming may be used. Saw cut joints may be used with conventional forming.

Bridge rail not shown for clarity.

Concrete in curb blockout shall be Class B-1.

Measurement of curb blockout is to the nearest linear foot, measured at the top outside edge of parapet. (Match existing curb and parapet)

All exposed edges of curb blockout shall have either a 1/2-inch radius or 3/8-inch bevel, unless otherwise noted.

Payment for concrete, reinforcement, resin anchor systems and any other work incidental to the curb blockout, complete in place, will be considered completely covered by the contract unit price for Curb Blockout per linear foot.

Cost of any concrete curb or parapet repair will be considered completely covered by the contract unit price for Curb Blockout.

All curb blockout reinforcement shall be epoxy coated.

(2) Shift resin anchors where necessary to clear existing anchor bolts for bridge rail, miss curb outlets (if present) and clear existing reinforcement.

Use a minimum lap of 3'-1" for #5 horizontal curb blockout bars.

Concrete traffic barrier delineators shall be placed on top of the curb blockout similarly as shown on Missouri Standard Plans 617.10 and in accordance with Sec 617. Delineators on bridges with two-lane, two-way traffic shall have retroreflective sheeting on both sides. Concrete traffic barrier delineators will be considered completely covered by the contract unit price for Curb Blockout.

The contractor shall use one of the qualified resin anchor systems in accordance with Sec 1039.

The minimum embedment depth in concrete with f'c = 4,000 psi for the resin anchor system shall be that required to meet the minimum ultimate pullout strength in accordance with Sec 1039 but shall not be less than 5 inches.

An epoxy coated #5 Grade 60 reinforcing bar shall be substituted for the 5/8"Ø threaded rod.



DATE PREPARED
9/25/2024

ROUTE 1-29 STATE MO
DISTRICT BR SHEET NO. 5

COUNTY ANDREW
JOB NO. J113262
CONTRACT ID.

PROJECT NO.

BRIDGE NO. A12903

DESCRIPTION	DATE

MISSOURI HIGHWAYS AND TRANSPORTATION COMMISSION

105 WEST CAPITOL JEFFERSON CITY, MO 65102
1-888-ASK-MODOT (1-888-275-6636)

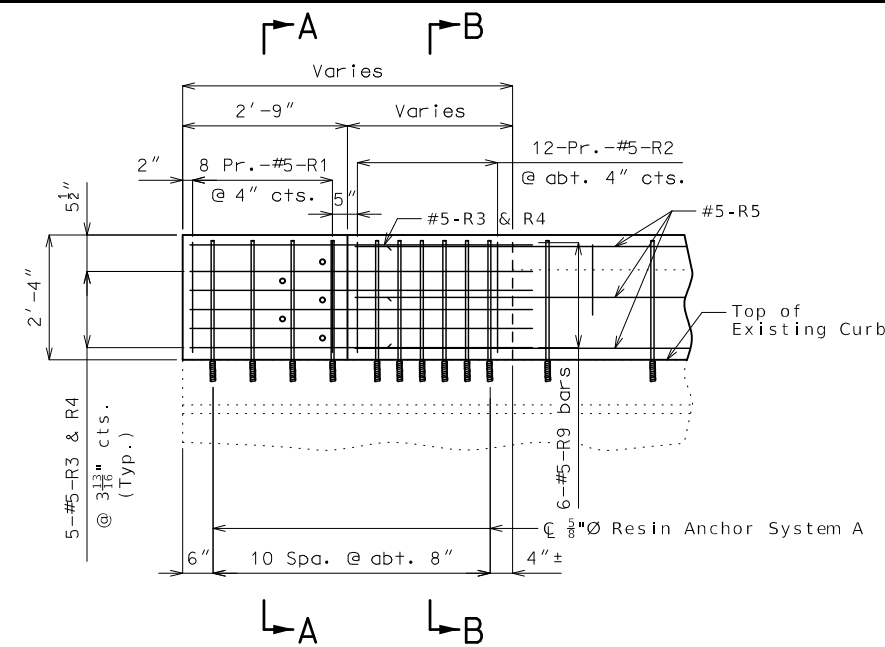

ELEVATION SHOWING
END POST REINFORCEMENT

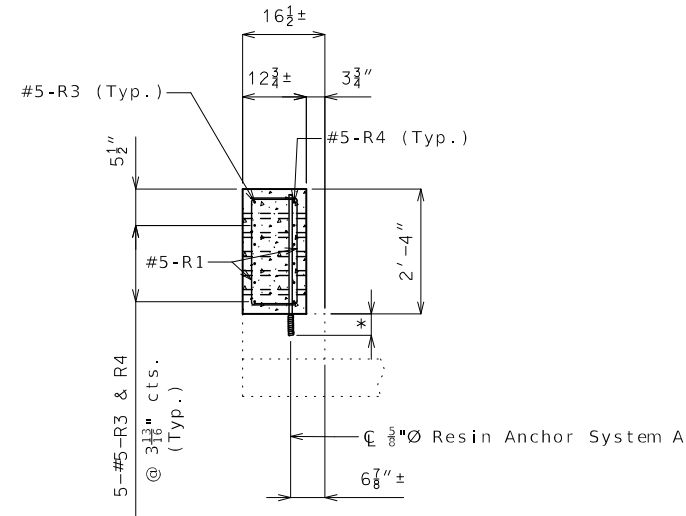

SECTION A-A

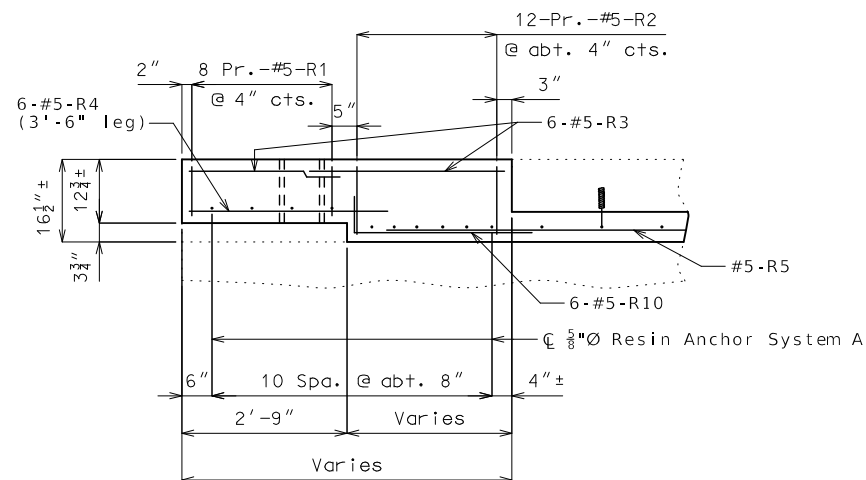

PLAN SHOWING
END POST REINFORCEMENT

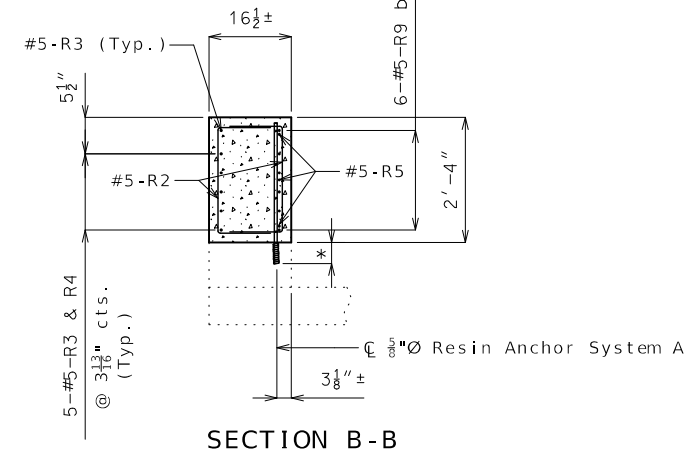

SECTION B-B

Manufacturer's recommended embedment length (5" min.)

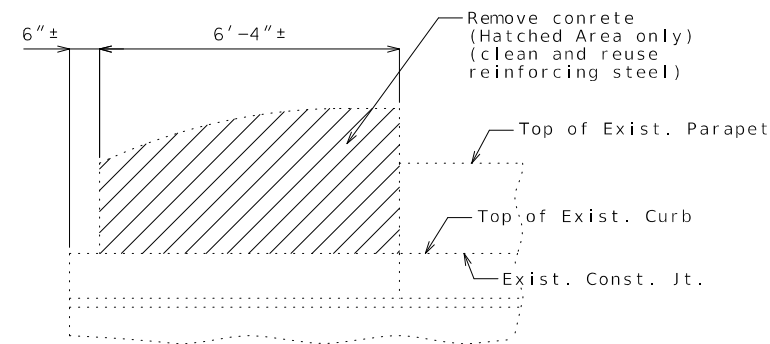

PART ELEVATION SHOWING END POST
CONCRETE REMOVAL

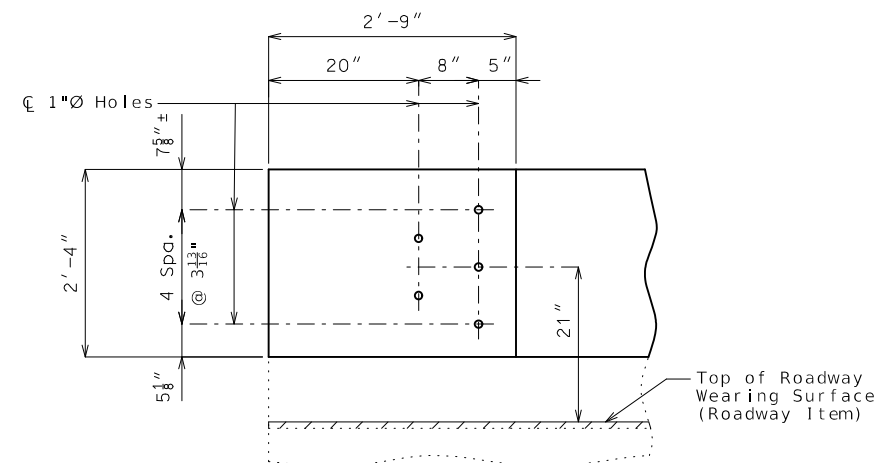

DETAILS OF GUARD RAIL
ATTACHMENT

DETAILS OF END POST AT END BENTS

Notes:

All exposed edges of curb blockout shall have 1/2" radius or 3/8" bevel unless otherwise shown.

Use a minimum lap of 3'-1" for #5 horizontal curb blockout bars.

Payment for concrete, reinforcing steel, resin anchor systems, and any other work incidental to the curb blockout, complete in place, will be included in the contract unit price for Curb Blockout per linear foot.

Cost of any concrete curb or parapet repair will be included in the contract unit price for Curb Blockout.

All reinforcement shall be epoxy coated.

For Details and notes of Resin Anchor Systems, see Sheet No. 5.

If there are additional R2 bars remaining after placing the bars based on the spacings shown, contractor may elect to not install the extra R2 bars, per the approval of the engineer.

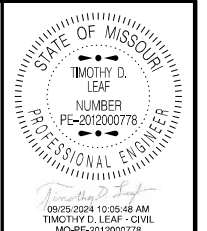

DATE PREPARED
9/25/2024

ROUTE	STATE
I - 29	MO
DISTRICT	SHEET NO.
BR	6

COUNTY
ANDREW

JOB NO.
J113262

CONTRACT ID.

PROJECT NO.

BRIDGE NO. A12903

DATE	DESCRIPTION

MISSOURI HIGHWAYS AND TRANSPORTATION COMMISSION

105 WEST CAPITOL
JEFFERSON CITY, MO 65102
1-888-ASK-MODOT (1-888-275-6636)

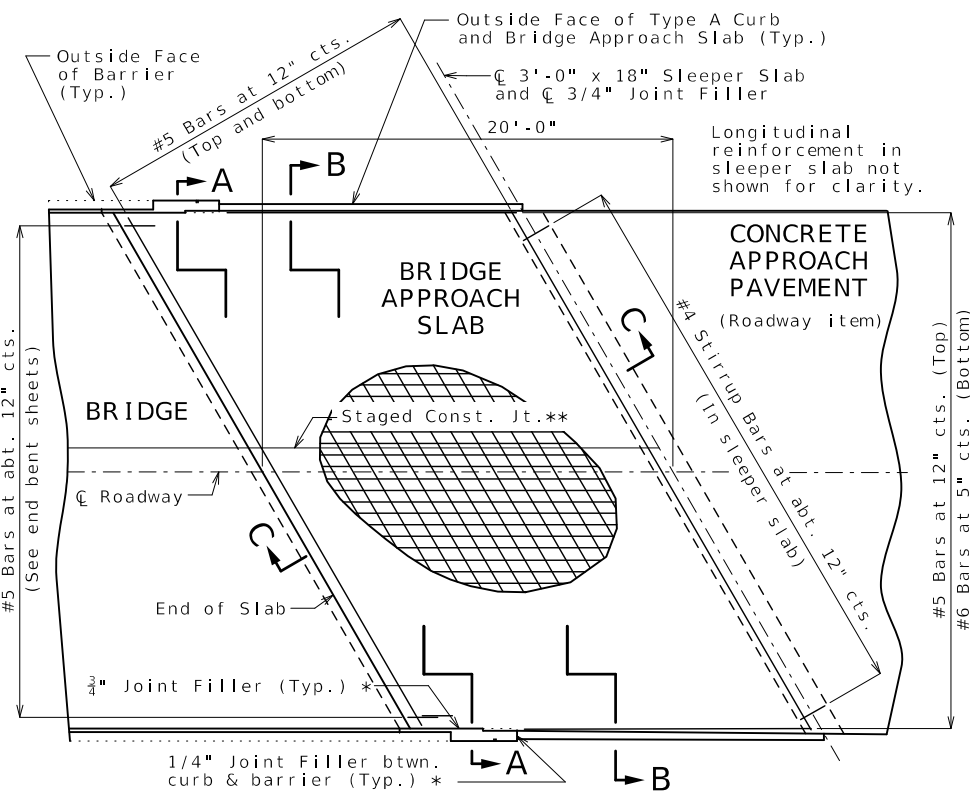

PART PLAN SHOWING REINFORCEMENT

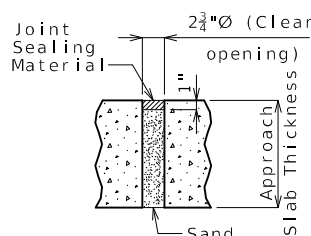

UNDERSEAL ACCESS HOLE DETAIL
(If required)

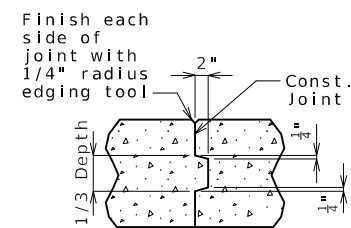

CONSTRUCTION JOINT DETAIL

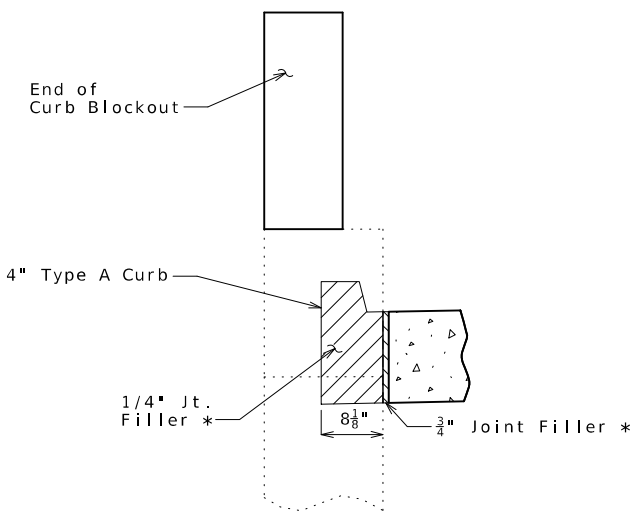

SECTION BETWEEN CURB AND BARRIER

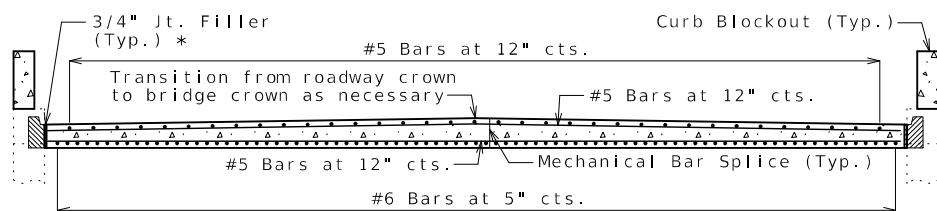

SECTION A-A

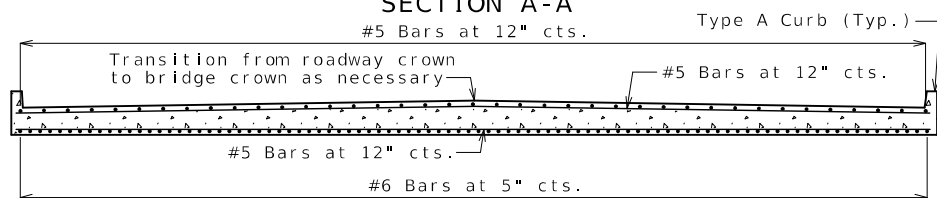

SECTION B-B

With the approval of the engineer, the contractor may crown the bottom of the approach slab to match the crown of the roadway surface.

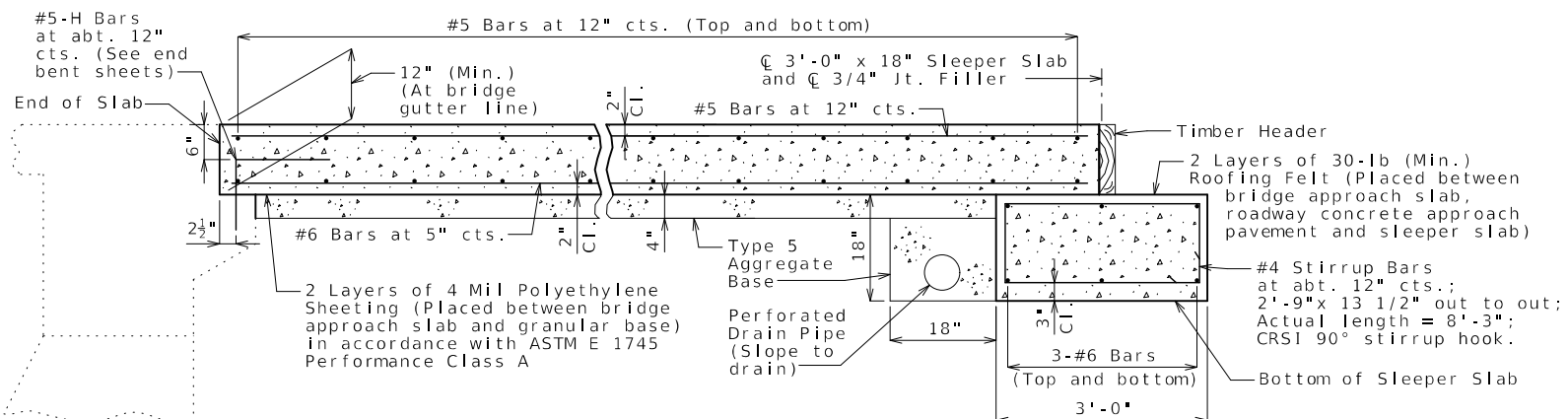

SECTION C-C

BRIDGE APPROACH SLAB (MAJOR)

General Notes:

All concrete for the bridge approach slab and sleeper slab shall be in accordance with Sec 503 ($f'c = 4,000$ psi).

The reinforcing steel in the bridge approach slab and the sleeper slab shall be epoxy coated Grade 60 with $f_y = 60,000$ psi.

Drain pipe may be either 6" diameter corrugated metallic-coated pipe underdrain, 4" diameter corrugated polyvinyl chloride (PVC) drain pipe, or 4" diameter corrugated polyethylene (PE) drain pipe.

Minimum clearance to reinforcing steel shall be 1 1/2", unless otherwise shown.

The reinforcing steel in the bridge approach slab and the sleeper slab shall be continuous. The transverse reinforcing steel may be made continuous by providing a minimum lap splice of 29 inches for #5 bars and 44 inches for #6 bars, or by mechanical bar splice.

Mechanical Bar Splices shall be in accordance with Sec. 710. (Estimated 70 splices per slab)

All joint filler shall be in accordance with Sec 1057 for preformed fiber expansion joint filler except as noted.

The contractor shall pour and satisfactorily finish the bridge slab before placing the bridge approach slab.

Longitudinal construction joints in approach slab and sleeper slab shall be aligned with longitudinal construction joints in bridge slab.

For concrete approach pavement details, see roadway plans.

See Missouri Standard Plan 609.00 for details of Type A curb.

Payment for furnishing all materials, labor and excavation necessary to construct the approach slab, including the timber header, sleeper slab, underdrain, Type 5 aggregate base, joint filler and all other appurtenances and incidental work as shown on this sheet, complete in place, will be considered completely covered by the contract unit price for Bridge Approach Slab (Major) per square yard.

*Seal joint between vertical face of approach slab and wing with sealant in accordance with Sec 717 for silicone joint sealant for saw cut and formed joints.

**Location of construction joint is approximate. See roadway plans for locations for staged traffic.

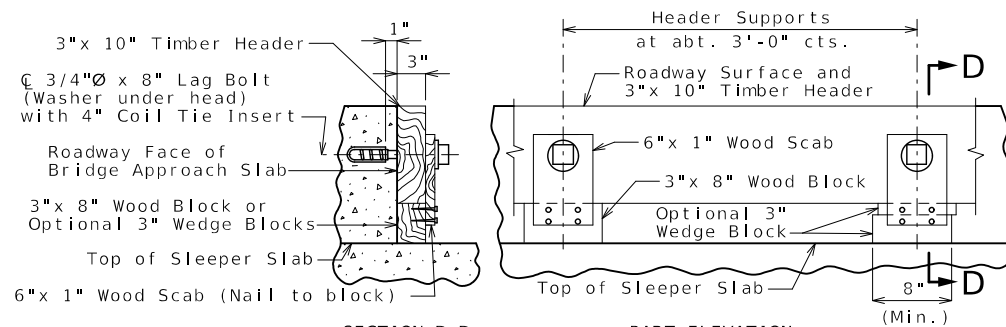

SECTION D-D

PART ELEVATION

DETAILS OF TIMBER HEADER

Remove timber header when concrete pavement is placed.

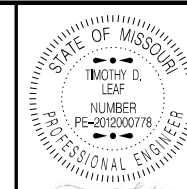

DATE PREPARED

9/25/2024

ROUTE

I-29

STATE

MO

DISTRICT

BR

SHEET NO.

7

COUNTY

ANDREW

JOB NO.

J113262

CONTRACT ID.

PROJECT NO.

BRIDGE NO.

A12903

DESCRIPTION

DATE

MISSOURI HIGHWAYS AND TRANSPORTATION COMMISSION

105 WEST CAPITOL JEFFERSON CITY, MO 65102 1-888-ASK-MODOT (1-888-275-6636)



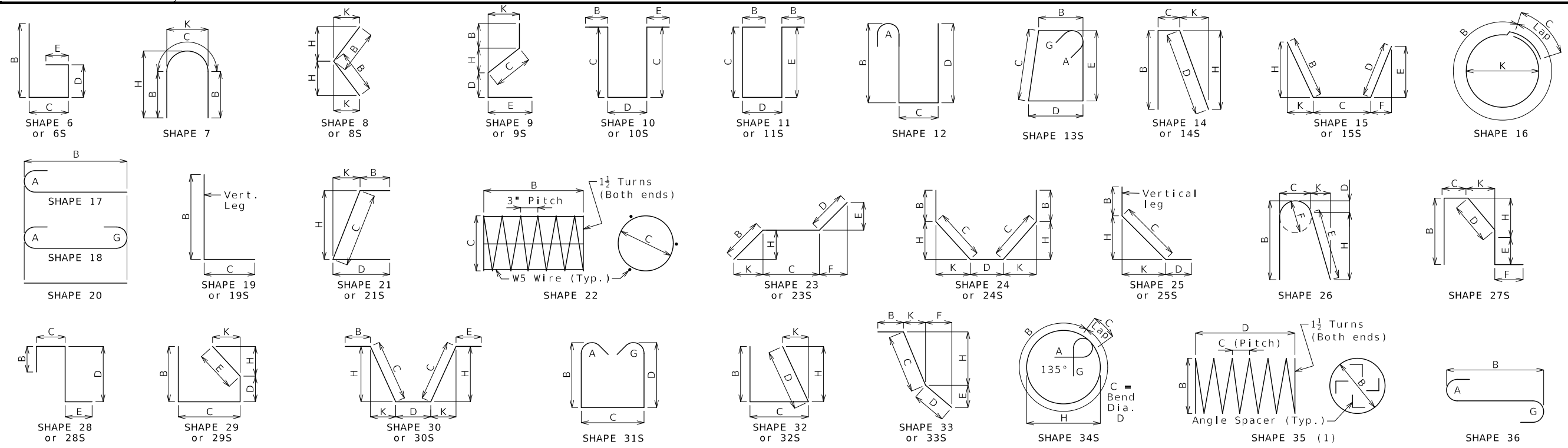

DATE PREPARED: 9/25/2024
 ROUTE: I-29 STATE: MO
 DISTRICT: BR SHEET NO.: 8
 COUNTY: ANDREW
 JOB NO.: J113262
 CONTRACT ID.:

PROJECT NO.:
 BRIDGE NO.: A12903

Finished Bend Diameters D and Hook Dimensions

Standard Pin Bend Shapes

Size	Case	D	A or G		J
			90°	180°	
#4	1	3"	8"	6"	4"
#5	1	3 3/8"	10"	7"	5"
#6	1	4 1/2"	12"	8 1/4"	6"
#7	2	5 1/4"	14"	9 3/4"	7"
	3	7"	15"	11 1/2"	8 3/4"
#8	2	6"	16"	11"	8"
	3	8"	17"	13 1/4"	10"
#9	1	9 1/2"	19 1/2"	15 1/2"	11 3/4"
#10	1	10 3/4"	22"	17 1/2"	13 1/4"
#11	1	12"	24 1/2"	19 1/2"	14 3/8"
#14	1	18 1/4"	31 1/4"	27 1/2"	21 5/8"
#18	1	24"	41 1/2"	36 1/4"	28 1/2"

Stirrup Pin Bend Shapes (S)

Size	Case	D	A or G		H	J
			90°	135°		
#4	2	2"	4 1/2"	4 1/2"	5"	2 3/8"
	3	3"	5"	5 1/2"	6"	3"
#5	2	2 1/2"	5 3/4"	5 3/4"	5 3/4"	3 3/8"
	3	3 3/4"	6 1/4"	6 1/2"	7"	3 5/8"
#6	1	4 1/2"	12"	7 3/4"	8 1/4"	4 3/8"

Applicable for all grades of steel. Case 1 applies to all reinforcement. Case 2 applies to all reinforcement except for galvanized bars. Case 3 applies to galvanized bars only.

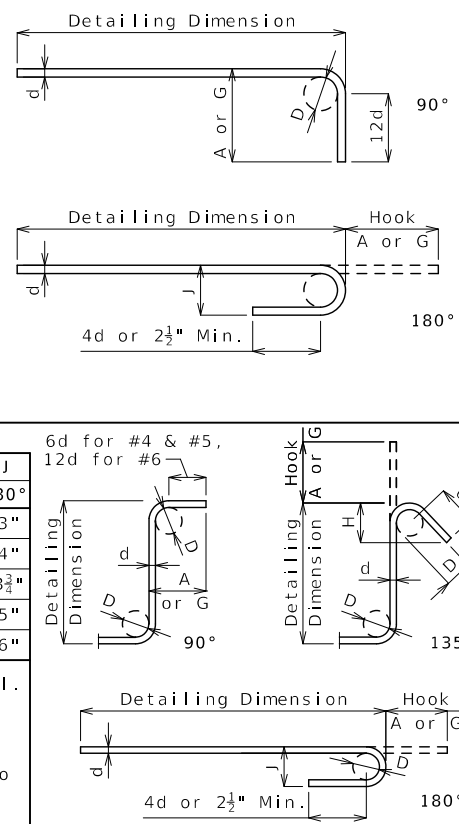

BENDING DIAGRAMS

Nominal lengths are based on out to out dimensions shown in bending diagrams and are listed to the nearest inch for fabricator's use. Actual lengths are measured along centerline bar to the nearest inch. Weights are based on actual lengths.

All bars shall be Grade 60.

Codes: C = Required coatings, where E = Epoxy Coated and G = Galvanized.

SH = Required shape, see bending diagrams.

V = Sets of varied bars and number of bars of each length. Bar dimensions vary in equal increments between dimensions shown on this line and the following line and the actual length dimension shown on this line and the following line vary by the specified increment.

All dimensions are out to out. (1) Shall be a deformed or plain spiral bar or wire.

Shapes ending with an S shall be bent in accordance with stirrup pin bend shapes.

Unless otherwise noted, finished bending diameter D is the same for all bends of a shape.

Four angle or channel spacers are required for each column spiral. Spacers are to be placed on inside of spirals. Length and weight of column spirals do not include splices or spacers.

Size	Substructure		Superstructure			Entire Bridge	
	Plain	Epoxy	Slab	Barrier	Slip Form	Plain	Epoxy
W5	0	0	0	0	0	0	0
4	0	0	0	0	0	0	0
5	0	0	0	3,583	0	0	3,583
6	0	0	0	0	0	0	0
7	0	0	0	0	0	0	0
By Type	0	0	0	3,583	0	0	3,583

All superstructure reinforcing steel shall be epoxy coated unless otherwise specified.

No. Req.	Size/ Mark	Location	Codes	Dimensions							Nom. Length	Actual Length	Weight			
				B	C	D	E	F	H	K						
		Barrier														
		Curb Blockout														
64	5 R1	BLOCKOUT	E 10S			9.75	21.00					3	5	3	2	211
96	5 R2	BLOCKOUT	E 10S			13.50	21.00					4	0	3	9	375
48	5 R3	BLOCKOUT	E 20		4	10.00						4	10	4	10	242
24	5 R4	BLOCKOUT	E 28S			2	9.00	3.75	3	1.00		6	2	5	11	148
48	5 R5	BLOCKOUT	E 20		10	4.00						10	4	10	4	517
8	5 R6	BLOCKOUT	E 20		47	5.00						47	5	47	5	396
16	5 R7	BLOCKOUT	E 20		47	5.00						47	5	47	5	791
8	5 R8	BLOCKOUT	E 20		47	5.00						47	5	47	5	396
8	5 R9	BLOCKOUT	E 20		45	3.00						45	3	45	3	378
24	5 R10	BLOCKOUT	E 19S		4	6.00	9.00					5	3	5	2	129

BENDING DIAGRAMS AND REINFORCING STEEL TOTALS

DESCRIPTION
 DATE
 MISSOURI HIGHWAYS AND TRANSPORTATION COMMISSION



DESIGN DESIGNATION

A.A.D.T. - 2023 = 17652
 T = 37.0%
 V = 70 M.P.H.
 D = 53.1% (N) / 46.9% (S)

FUNCTIONAL CLASSIFICATION - INTERSTATE

NO RIGHT-OF-WAY ACQUISITION

**MISSOURI HIGHWAYS AND TRANSPORTATION COMMISSION
 PLANS FOR PROPOSED
 STATE HIGHWAY
 ATCHISON COUNTY**

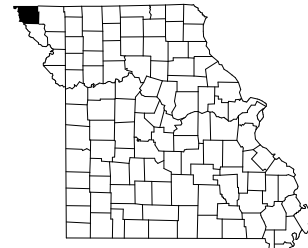

KEY MAP
 LOCATION OF ATCHISON COUNTY

INDEX OF SHEETS

DESCRIPTION	SHEET NUMBER
TITLE SHEET	1
TYPICAL SECTIONS (TS) (3 SHEETS)	2
QUANTITIES (QU) (3 SHEETS)	3
PLAN-PROFILE (PP)	4
SPECIAL SHEETS (SS)	5-9
TRAFFIC CONTROL SHEETS (TC)	10-21
EROSION CONTROL SHEETS (EC)	22
CULVERT SECTIONS (CS)	23
BRIDGE DRAWINGS (B)	
A27143	1-8
A27144	1-8

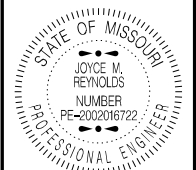

DATE PREPARED
 10/7/2024

ROUTE 1-29 STATE MO
 DISTRICT NW SHEET NO. 1

COUNTY
 ATCHISON
 JOB NO.
 J113280
 CONTRACT ID.

PROJECT NO.
 BRIDGE NO.

DATE	DESCRIPTION

**CONVENTIONAL SYMBOLS
 (USED IN PLANS)**

	EXISTING	NEW
BUILDINGS AND STRUCTURES		
GUARD RAIL		
GUARD CABLE		
CONCRETE RIGHT-OF-WAY MARKER		
STEEL RIGHT-OF-WAY MARKER		
LOCATION SURVEY MARKER		
UTILITIES		
FIBER OPTICS	-FO-	-FO-
OVERHEAD CABLE TV	-OTV-	-OTV-
UNDERGROUND CABLE TV	-UTV-	-UTV-
OVERHEAD TELEPHONE	-OT-	-OT-
UNDERGROUND TELEPHONE	-UT-	-UT-
OVERHEAD POWER	-OE-	-OE-
UNDERGROUND POWER	-UE-	-UE-
SANITARY SEWER	-S-	-S-
STORM SEWER	-SS-	-SS-
GAS	-G-	-G-
WATER	-W-	-W-
MANHOLE		
FIRE HYDRANT		
WATER VALVE		
WATER METER		
DROP INLET		
DITCH BLOCK		
GROUND MOUNTED SIGN		
LIGHT POLE		
H-FRAME POWER POLE		
TELEPHONE PEDESTAL		
FENCE		
CHAIN LINK		
WOVEN WIRE		
GATE POST		
BENCHMARK		

NOTE: DASHED OR OPEN SYMBOLS INDICATE EXISTING FEATURES

JOB NO. J113280
 REHABILITATE BRIDGES A2714
 OVER MILL CREEK
 LENGTH = 0.149 MILE

BEGIN PROJECT
 STA. 1154+86.43
 LOG MILE 21.737

END PROJECT
 STA. 1162+71.70
 LOG MILE 21.886

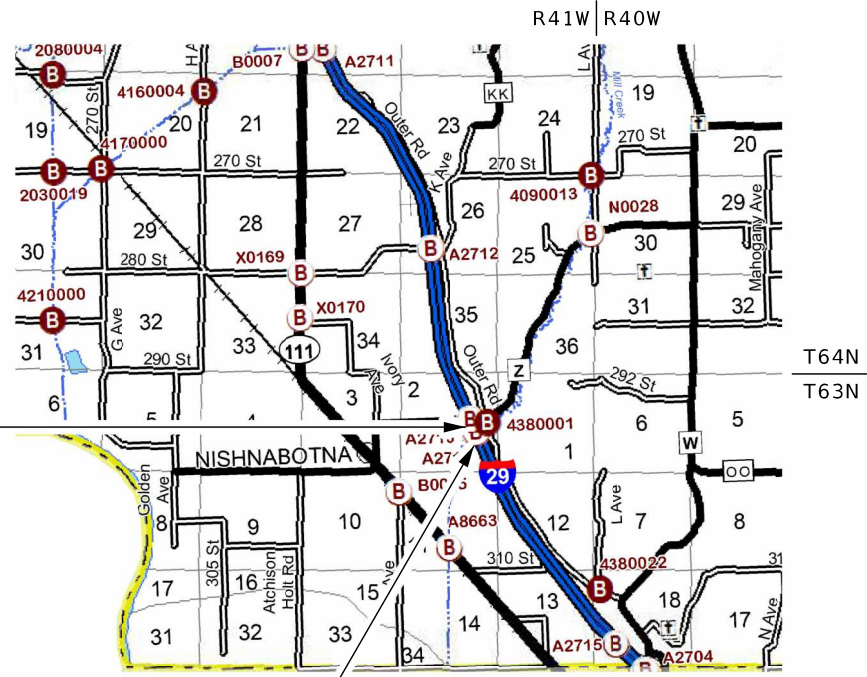

THE EXISTENCE AND APPROXIMATE LOCATION OF UTILITY FACILITIES KNOWN TO EXIST, AS SHOWN ON THE PLANS, ARE BASED ON THE BEST INFORMATION AVAILABLE TO THE COMMISSION AT THIS TIME. THIS INFORMATION IS PROVIDED BY THE COMMISSION "AS-IS" AND THE COMMISSION EXPRESSLY DISCLAIMS ANY REPRESENTATION OR WARRANTY AS TO THE COMPLETENESS, ACCURACY, OR SUITABILITY OF THE INFORMATION FOR ANY USE. RELIANCE UPON THIS INFORMATION IS DONE AT THE RISK AND PERIL OF THE USER, AND THE COMMISSION SHALL NOT BE LIABLE FOR ANY DAMAGES THAT MAY ARISE FROM ANY ERROR IN THE INFORMATION. IT IS, THEREFORE, THE RESPONSIBILITY OF THE CONTRACTOR TO VERIFY THE EXISTENCE, LOCATION AND STATUS OF ANY FACILITY. SUCH VERIFICATION INCLUDES DIRECT CONTACT WITH THE LISTED UTILITIES.

LENGTH OF PROJECT

BEGINNING OF PROJECT	STA. 1154+86.43
END OF PROJECT	STA. 1162+71.70
APPARENT LENGTH	785.27 FEET
EQUATIONS AND EXCEPTIONS:	NONE
TOTAL CORRECTIONS	0.00 FEET
NET LENGTH OF PROJECT	785.27 FEET
STATE LENGTH	0.149 MILE
FOR INFORMATION ONLY ESTIMATED DISTURBED ACRES	<1 ACRE

MISSOURI HIGHWAYS AND TRANSPORTATION COMMISSION

105 WEST CAPITOL
 JEFFERSON CITY, MO 65102
 1-888-ASK-MODOT (1-888-275-6636)

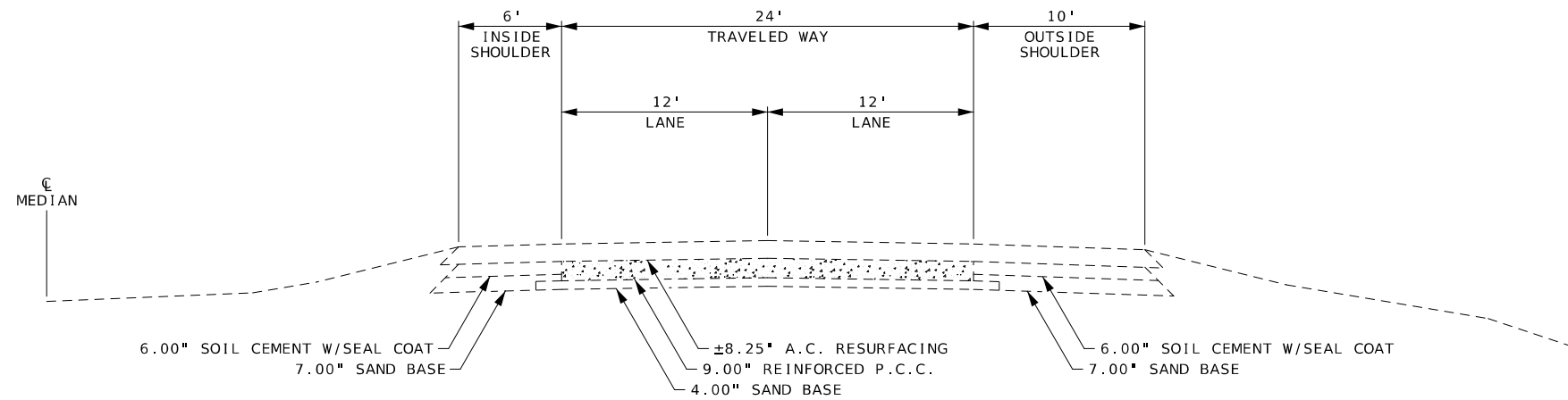

HALF-SECTION ON TANGENT
 EXISTING TYPICAL SECTION ROUTE I-29
 STA. 1154+06.23 TO STA. 1163+51.90

ESTIMATE FACTORS *		
ITEM	DESCRIPTION	FACTOR
403-01.05	ASPHALTIC CONCRETE MIXTURE PG76-22 (SP125C MIX)	1.99 TONS/CU. YD.
407-10.05	TACK COAT - ON EXISTING MILLED ASPHALT	0.10 GAL./SQ. YD.

* FOR INFORMATION PURPOSES ONLY

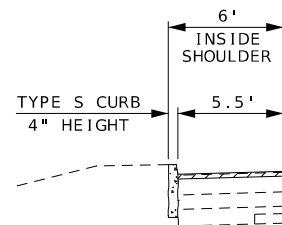

* BUILD TYPE S CURB ADJACENT TO INSIDE SHOULDER AT THE FOLLOWING LOCATIONS
 N.B.L. STA. 1159+81.81 TO STA. 1159+91.71
 S.B.L. STA. 1159+97.40 TO STA. 1160+00.34

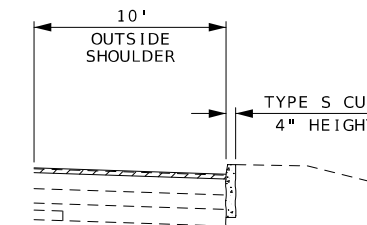

** BUILD TYPE S CURB ADJACENT TO OUTSIDE SHOULDER AT THE FOLLOWING LOCATIONS
 N.B.L. STA. 1159+81.81 TO STA. 1159+84.74
 S.B.L. STA. 1159+97.40 TO STA. 1160+07.30

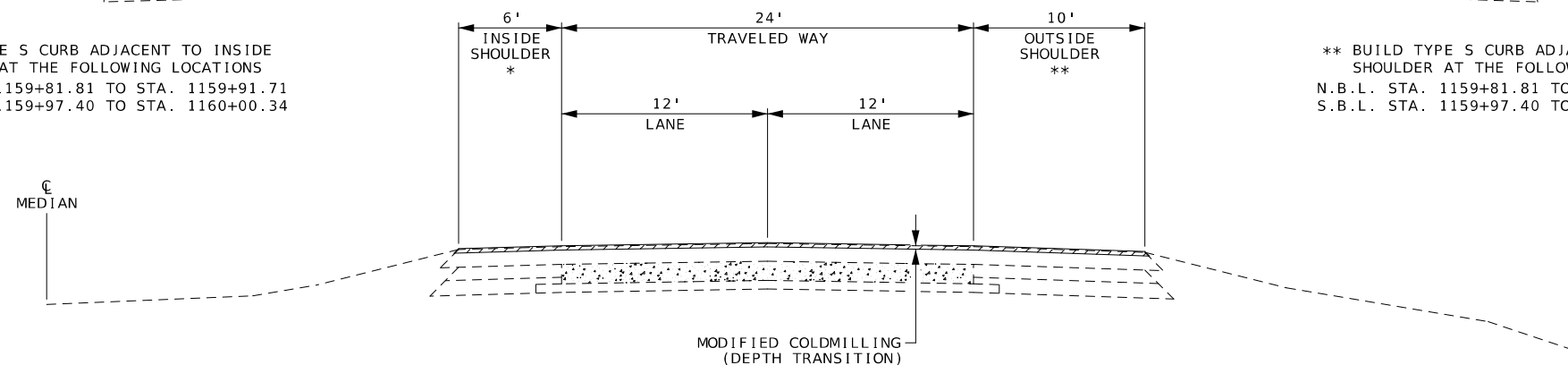

HALF-SECTION ON TANGENT
 EXISTING TYPICAL SECTION ROUTE I-29
 N.B.L. STA. 1156+45.72 TO STA. 1157+60.72
 STA. 1159+81.81 TO STA. 1160+96.81
 S.B.L. STA. 1156+61.31 TO STA. 1157+76.31
 STA. 1159+97.40 TO STA. 1161+12.40

NOT TO SCALE

TYPICAL SECTIONS
 SHEET 1 OF 3

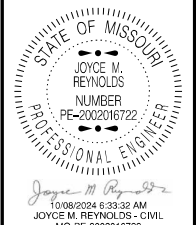

DATE PREPARED 10/7/2024	
ROUTE I-29	STATE MO
DISTRICT NW	SHEET NO. 2
COUNTY ATCHISON	
JOB NO. J113280	
CONTRACT ID.	
PROJECT NO.	
BRIDGE NO.	

DATE	DESCRIPTION

MISSOURI HIGHWAYS AND TRANSPORTATION COMMISSION

105 WEST CAPITOL
 JEFFERSON CITY, MO 65102
 1-888-ASK-MODOT (1-888-275-6636)

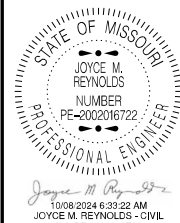

DATE PREPARED
10/7/2024

ROUTE 1-29 STATE MO

DISTRICT NW SHEET NO. 2

COUNTY ATCHISON

JOB NO. J113280

CONTRACT ID.

PROJECT NO.

BRIDGE NO.

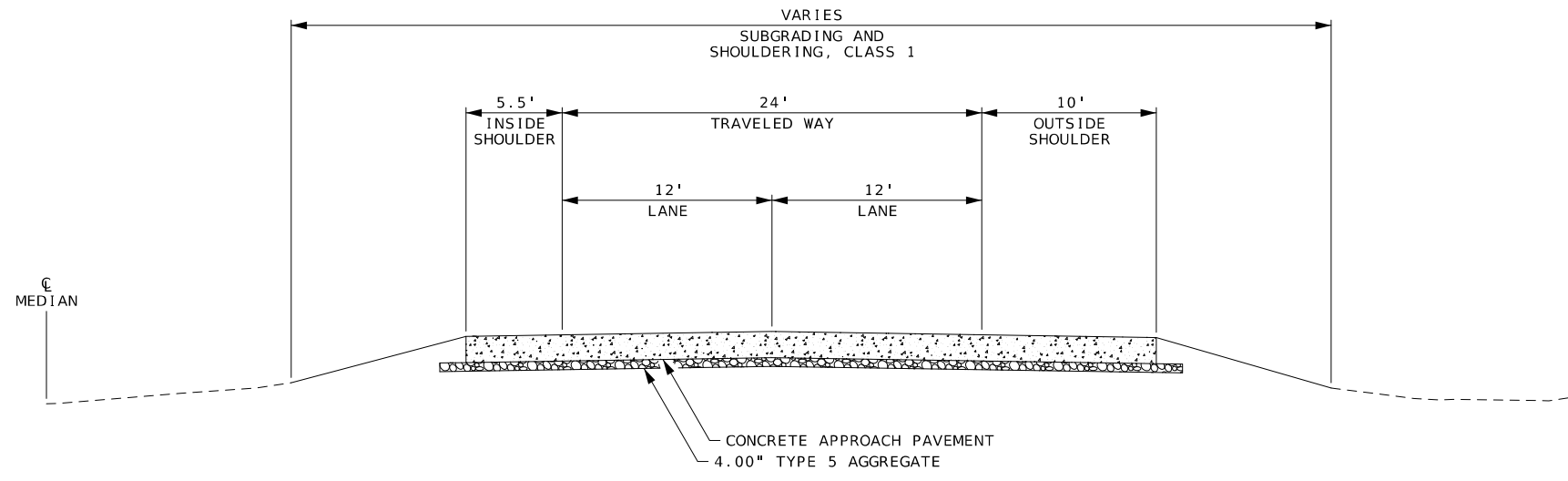

HALF-SECTION ON TANGENT
 PROPOSED TYPICAL SECTION ROUTE 1-29
 N.B.L. STA. 1157+60.72 TO STA. 1157+79.20
 S.B.L. STA. 1157+76.31 TO STA. 1157+94.80

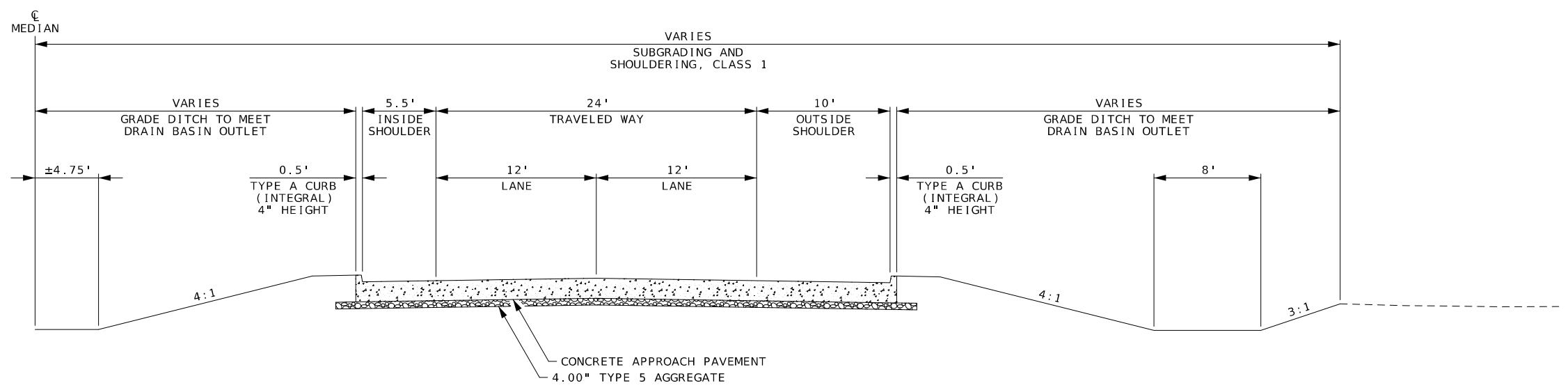

HALF-SECTION ON TANGENT
 PROPOSED TYPICAL SECTION ROUTE 1-29
 N.B.L. STA. 1159+63.33 TO STA. 1159+81.81
 S.B.L. STA. 1159+78.92 TO STA. 1159+97.40

NOTE: SEE BRIDGE PLANS FOR BRIDGE APPROACH SLAB AND BRIDGE REHABILITATION DETAILS.

NOT TO SCALE

DATE	DESCRIPTION

MISSOURI HIGHWAYS AND TRANSPORTATION COMMISSION

MoDOT

105 WEST CAPITOL JEFFERSON CITY, MO 65102 1-888-ASK-MODOT (1-888-275-6636)

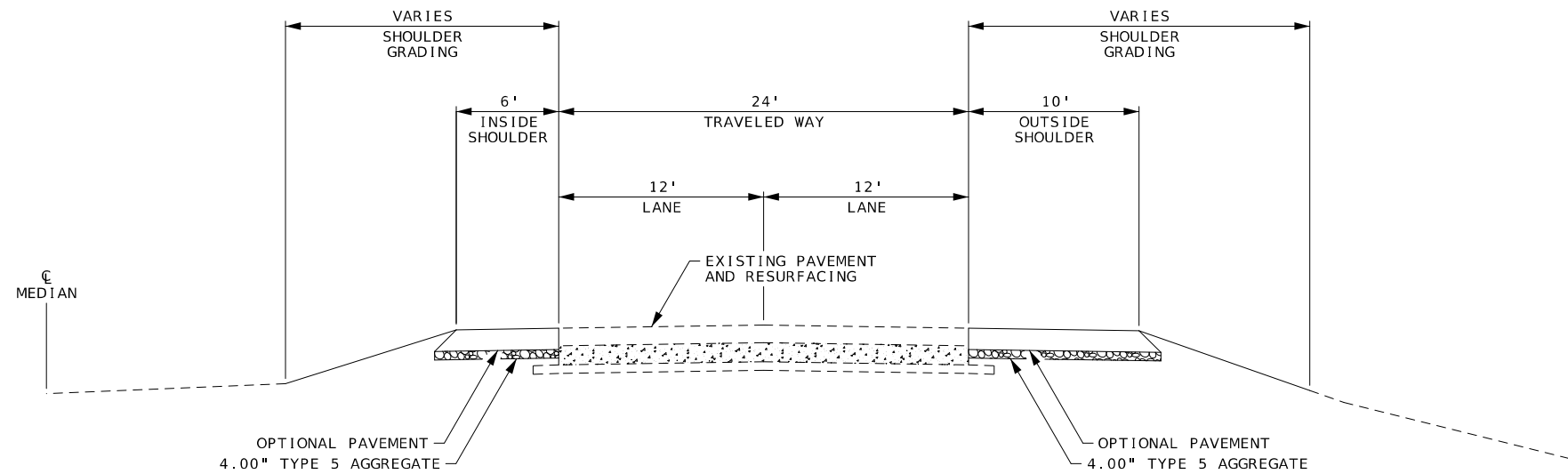

HALF-SECTION ON TANGENT
PROPOSED TYPICAL SECTION SHOULDER RECONSTRUCTION
 (CONSTRUCT PRIOR TO THE SHIFTING OF TRAFFIC ONTO THE SHOULDER)

S.B.L. OUTSIDE SHOULDER	STA. 1154+06.23 TO STA. 1157+91.23
	STA. 1159+82.41 TO STA. 1162+32.41
S.B.L. INSIDE SHOULDER	STA. 1154+06.23 TO STA. 1157+91.23
	STA. 1159+82.41 TO STA. 1162+32.41
N.B.L. OUTSIDE SHOULDER	STA. 1155+25.72 TO STA. 1157+75.72
	STA. 1159+66.90 TO STA. 1163+51.90
N.B.L. INSIDE SHOULDER	STA. 1155+25.72 TO STA. 1157+75.72
	STA. 1159+66.90 TO STA. 1163+51.90

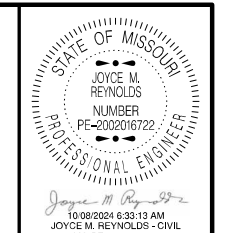
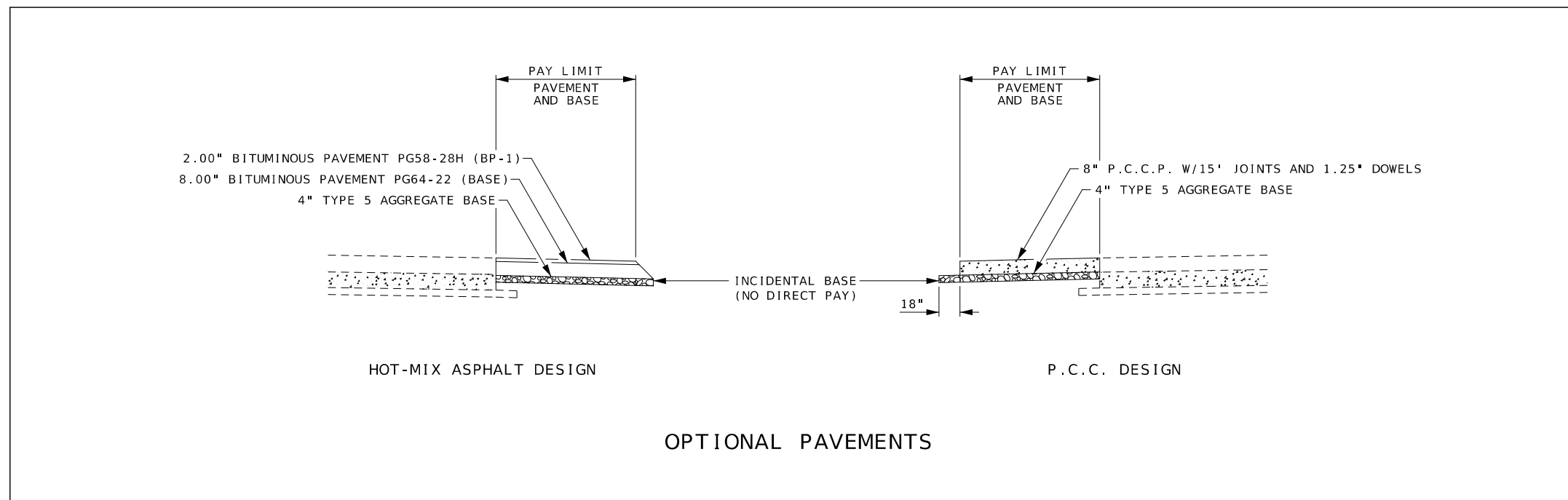

DATE PREPARED
10/7/2024

ROUTE I - 29	STATE MO
DISTRICT NW	SHEET NO. 2

COUNTY
ATCHISON

JOB NO.
J113280

CONTRACT ID.

PROJECT NO.

BRIDGE NO.

DATE	DESCRIPTION

MISSOURI HIGHWAYS AND TRANSPORTATION COMMISSION

105 WEST CAPITOL
 JEFFERSON CITY, MO 65102
 1-888-ASK-MODOT (1-888-275-6636)

NOT TO SCALE

TYPICAL SECTIONS
 SHEET 3 OF 3

REMOVAL OF IMPROVEMENTS			
STATION	STATION	LOCATION	DESCRIPTION
1154+06.23	1157+91.23	S.B.L. O/S SHLDR.	428 S.Y. SHOULDER
1154+06.23	1157+91.23	S.B.L. I/S SHLDR.	257 S.Y. SHOULDER
1155+25.72	1157+75.72	N.B.L. I/S SHLDR.	167 S.Y. SHOULDER
1155+25.72	1157+75.72	N.B.L. O/S SHLDR.	278 S.Y. SHOULDER
1155+48.17	1158+06.31	S.B.L. I/S SHLDR.	258 L.F. GUARDRAIL; INCLUDES TRANSITION AND BR. ANCHOR SECTIONS
1155+67.63	1158+13.28	S.B.L. O/S SHLDR.	246 L.F. GUARDRAIL; INCLUDES TRANSITION AND BR. ANCHOR SECTIONS
1157+60.72	1158+02.69	N.B.L.	170 S.Y. PAVEMENT AND SHOULDER; INCLUDES BRIDGE APPROACH SLAB
1157+76.31	1158+18.28	S.B.L.	170 S.Y. PAVEMENT AND SHOULDER; INCLUDES BRIDGE APPROACH SLAB
1159+39.85	1159+81.81	N.B.L.	170 S.Y. PAVEMENT AND SHOULDER; INCLUDES BRIDGE APPROACH SLAB
1159+44.85	1161+90.49	N.B.L. O/S SHLDR.	246 L.F. GUARDRAIL; INCLUDES TRANSITION AND BR. ANCHOR SECTIONS
1159+47.85	1159+67.85	N.B.L. O/S SHLDR.	DRAIN BASIN
1159+51.81	1162+09.96	N.B.L. I/S SHLDR.	258 L.F. GUARDRAIL; INCLUDES TRANSITION AND BR. ANCHOR SECTIONS
1159+54.81	1159+74.81	N.B.L. I/S SHLDR.	DRAIN BASIN
1159+55.44	1159+97.40	S.B.L.	170 S.Y. PAVEMENT AND SHOULDER; INCLUDES BRIDGE APPROACH SLAB
1159+63.44	1159+83.44	S.B.L. I/S SHLDR.	DRAIN BASIN
1159+66.90	1163+51.90	N.B.L. O/S SHLDR.	428 S.Y. SHOULDER
1159+66.90	1163+51.90	N.B.L. I/S SHLDR.	257 S.Y. SHOULDER
1159+68.44	1159+83.44	MEDIAN	63 S.Y. PAVED DITCH
1159+70.40	1159+90.40	S.B.L. O/S SHLDR.	DRAIN BASIN
1159+82.41	1162+32.41	S.B.L. I/S SHLDR.	167 S.Y. SHOULDER
1159+82.41	1162+32.41	S.B.L. O/S SHLDR.	278 S.Y. SHOULDER
			1 LUMP SUM

SUBGRADING AND SHOULDERING					
STATION	STATION	LOCATION	SUBGRADE COMPACTION (6 IN. DEPTH) (100 FT.)	SUBGRADING AND SHOULDERING CLASS 1 (100 FT.)	REMARKS
1157+60.72	1158+02.69	N.B.L.	0.4	0.4	
1157+76.31	1158+18.28	S.B.L.	0.4	0.4	
1159+39.85	1161+35.00	N.B.L.	2.0	2.0	INCL. GRADING DITCHES TO MEET DRAIN BASIN OUTLETS
1159+55.44	1161+35.00	S.B.L.	1.8	1.8	INCL. GRADING DITCHES TO MEET DRAIN BASIN OUTLETS
TOTALS			4.6	4.6	
PAY TOTALS			5	5	

CHANNEL CLEANOUT		ESTIMATED QUANTITY (CU. YD.)
LOCATION		
FROM 100' WEST OF BRIDGE A27144 TO 100' EAST OF BRIDGE A27143		6780
1 LUMP SUM		

SHOULDER GRADING				
STATION	STATION	LOCATION	LENGTH (FT.)	SHOULDER GRADING (100 FT.)
1154+06.23	1157+91.23	S.B.L. O/S SHLDR.	385.00	3.85
1154+06.23	1157+91.23	S.B.L. I/S SHLDR.	385.00	3.85
1155+25.72	1157+75.72	N.B.L. I/S SHLDR.	250.00	2.50
1155+25.72	1157+75.72	N.B.L. O/S SHLDR.	250.00	2.50
1159+66.90	1163+51.90	N.B.L. O/S SHLDR.	385.00	3.85
1159+66.90	1163+51.90	N.B.L. I/S SHLDR.	385.00	3.85
1159+82.41	1162+32.41	S.B.L. I/S SHLDR.	250.00	2.50
1159+82.41	1162+32.41	S.B.L. O/S SHLDR.	250.00	2.50
TOTALS			25.40	
PAY TOTALS			25	

PAVEMENT AND BASE								
STATION	STATION	LOCATION	LENGTH (FT.)	WIDTH (FT.)	TYPE 5 AGGR. FOR BASE (4 IN. THICK) (SQ. YD.)	OPTIONAL PAVEMENT (SQ. YD.)	CONCRETE APPROACH PAVEMENT (SQ. YD.)	REMARKS
1154+06.23	1157+91.23	S.B.L. O/S SHLDR.	385.00	10.00	427.8	427.78		SHOULDER REPLACEMENT
1154+06.23	1157+91.23	S.B.L. I/S SHLDR.	385.00	6.00	256.7	256.67		SHOULDER REPLACEMENT
1155+25.72	1157+75.72	N.B.L. I/S SHLDR.	250.00	6.00	166.7	166.67		SHOULDER REPLACEMENT
1155+25.72	1157+75.72	N.B.L. O/S SHLDR.	250.00	10.00	277.8	277.78		SHOULDER REPLACEMENT
1157+60.72	1157+79.20	N.B.L.	18.48	39.5	81.1		81.11	
1157+76.31	1157+94.80	S.B.L.	18.48	39.5	81.1		81.11	
1159+63.33	1159+81.81	N.B.L.	18.48	40.5	83.2		83.16	INCLUDES TYPE A CURB
1159+78.92	1159+97.40	S.B.L.	18.48	40.5	83.2		83.16	INCLUDES TYPE A CURB
1159+66.90	1163+51.90	N.B.L. O/S SHLDR.	385.00	10.00	427.8	427.78		SHOULDER REPLACEMENT
1159+66.90	1163+51.90	N.B.L. I/S SHLDR.	385.00	6.00	256.7	256.67		SHOULDER REPLACEMENT
1159+82.41	1162+32.41	S.B.L. I/S SHLDR.	250.00	6.00	166.7	166.67		SHOULDER REPLACEMENT
1159+82.41	1162+32.41	S.B.L. O/S SHLDR.	250.00	10.00	277.8	277.78		SHOULDER REPLACEMENT
TOTALS					2586.6	2257.80	328.54	
PAY TOTALS					2587	2257.8	328.5	

TYPE S CURB					
STATION	STATION	LOCATION	LENGTH (FT.)	CONCRETE CURB (6" HEIGHT AND UNDER) TYPE S (LIN. FT.)	REMARKS
1159+81.81	1159+84.74	N.B.L. O/S SHLDR.	2.93	2.9	4" CURB HEIGHT
1159+81.81	1159+91.71	N.B.L. I/S SHLDR.	9.90	9.9	4" CURB HEIGHT
1159+97.40	1160+00.34	S.B.L. I/S SHLDR.	2.93	2.9	4" CURB HEIGHT
1159+97.40	1160+07.30	S.B.L. O/S SHLDR.	9.90	9.9	4" CURB HEIGHT
TOTAL				25.6	
PAY TOTAL				26	

MODIFIED COLDMILLING						
STATION	STATION	LOCATION	LENGTH (FT.)	WIDTH (FT.)	MODIFIED COLDMILLING (DEPTH TRANSITION) (SQ. YD.)	REMARKS
1156+45.72	1157+60.72	N.B.L.	115.00	40.00	511.1	2.00" TO 0.85"
1156+61.31	1157+76.31	S.B.L.	115.00	40.00	511.1	2.00" TO 0.85"
1159+81.81	1160+96.81	N.B.L.	115.00	40.00	511.1	0.85" TO 2.00"
1159+97.40	1161+12.40	S.B.L.	115.00	40.00	511.1	0.85" TO 2.00"
TOTALS					2044.4	
PAY TOTALS					2044	

SP125C RESURFACING											
STATION	STATION	LOCATION	LENGTH (FT.)	ASPHALTIC CONCRETE MIXTURE PG76-22 (SP125C MIX)					TACK COAT		
				WIDTH (FT.)	THICKNESS (IN.)	VOLUME (CU. YD.)	FACTOR (T/CY)	(TONS)	AREA (SQ. YD.)	FACTOR (G/SY)	(GALS.)
1156+45.72	1157+60.72	N.B.L.	115.00	40.00	2.00	28.40	1.99	56.52	511.11	0.10	51.1
1156+61.31	1157+76.31	S.B.L.	115.00	40.00	2.00	28.40	1.99	56.52	511.11	0.10	51.1
1159+81.81	1160+96.81	N.B.L.	115.00	40.00	2.00	28.40	1.99	56.52	511.11	0.10	51.1
1159+97.40	1161+12.40	S.B.L.	115.00	40.00	2.00	28.40	1.99	56.52	511.11	0.10	51.1
TOTALS								226.08		204.4	
PAY TOTALS								226.1		204	

EMBANKMENT PROTECTION					
STATION	STATION	TYPE 2 ROCK BLANKET			PERMANENT EROSION CONTROL GEOTEXTILE (SQ. YD.)
		THICKNESS (FT.)	FURNISHING (CU. YD.)	PLACING (CU. YD.)	
1157+88.00	1158+60.00	2.00	558.1	558.1	947.7
1158+98.00	1159+70.00	2.00	525.5	525.5	897.9
TOTALS			1083.6	1083.6	1845.6
PAY TOTALS			1084	1084	1846

DRAINAGE STRUCTURES							
STATION	LOCATION	CLASS 3 EXCAVATION (CU. YD.)	DRAIN BASIN (EACH)	CONCRETE SLOPE PROTECTION (SQ. YD.)	CURVED VANE GRATE AND FRAME (4 FT. x 2 FT.) (EACH)	12 IN. PIPE GROUP C (LIN. FT.)	PRECAST CONCRETE DROP INLET (4 FT. x 2 FT.) (FT.)
1159+67.55	N.B.L. O/S SHLDR.	7.7	1	3.9	1	18.3	2.0
1159+74.52	N.B.L. I/S SHLDR.	7.4	1	3.9	1	18.3	2.0
1159+83.15	S.B.L. I/S SHLDR.	7.2	1	3.9	1	18.3	2.0
1159+90.11	S.B.L. O/S SHLDR.	8.9	1	3.9	1	18.3	2.0
TOTALS		31.2	4	15.6	4	73.2	8.0
PAY TOTALS		31	4	*	*	*	*

MOBILIZATION	
LOCATION	ESTIMATED QUANTITY (CU. YD.)
1 LUMP SUM	

SUMMARY OF QUANTITIES
SHEET 1 OF 3

* THESE ITEMS INCLUDED IN COST OF DRAIN BASIN

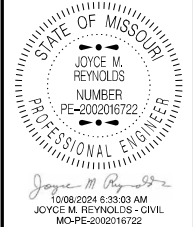

DATE PREPARED	10/7/2024
ROUTE	I-29
DISTRICT	NW
STATE	MO
SHEET NO.	3
COUNTY	
ATTACH ION	
JOB NO.	J113280
CONTRACT ID.	
PROJECT NO.	
BRIDGE NO.	

DESCRIPTION

DATE

MISSOURI HIGHWAYS AND TRANSPORTATION COMMISSION

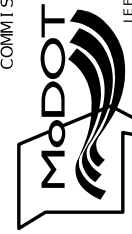

105 WEST CAPITOL
JEFFERSON CITY, MO 65102
1-888-ASK-MODOT (1-888-275-6636)

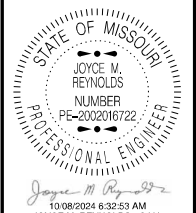

DATE PREPARED
10/7/2024
ROUTE
I-29
STATE
MO
DISTRICT
NW
SHEET NO.
3

COUNTY
ATCHISON
JOB NO.
J113280
CONTRACT ID.
PROJECT NO.
BRIDGE NO.

DESCRIPTION	DATE

MISSOURI HIGHWAYS AND TRANSPORTATION COMMISSION
105 WEST CAPITOL
JEFFERSON CITY, MO 65102
1-888-ASK-MODOT (1-888-275-6636)

GUARDRAIL							
STATION	STATION	LOCATION	SHAPING SLOPES CLASS III (100 FT.)	MGS GUARDRAIL (LIN. FT.)	MGS BRIDGE APPROACH TRANSITION SECTION (EXT. CURB) (EACH)	GUADRAIL RELOCATED AND MODIFIED (LIN. FT.)	REMARKS
1155+16.43	1158+05.81	S.B.L. I/S SHLDR.	3.17	200.0	1	50.0	MASH CET RELOCATED FROM 1154+98.17 TO 1155+48.17 S.B.L. I/S SHLDR.
1155+73.39	1158+12.78	S.B.L. O/S SHLDR.	2.67	150.0	1	50.0	MASH CET RELOCATED FROM 1155+17.63 TO 1155+67.63 S.B.L. O/S SHLDR.
1159+45.35	1161+84.73	N.B.L. O/S SHLDR.	2.67	150.0	1	50.0	MASH CET RELOCATED FROM 1161+90.49 TO 1162+40.49 N.B.L. O/S SHLDR.
1159+52.31	1162+41.70	N.B.L. I/S SHLDR.	3.17	200.0	1	50.0	MASH CET RELOCATED FROM 1162+09.96 TO 1162+59.96 N.B.L. I/S SHLDR.
TOTALS			11.68	700.0	4	200.0	
PAY TOTALS			12	700	4	200	

PAVEMENT MARKING REMOVAL					
STAGE	STATION	STATION	LOCATION	PAVEMENT MARKING REMOVAL (LIN. FT.)	REMARKS
PRIOR TO INSIDE LANE CLOSURE	1139+05.40	1161+53.32	S.B.L. CL	561.98	EXISTING INTERMITTENT LANE LINE
	1154+14.78	1162+23.94	S.B.L. O/S	809.16	EXISTING OUTSIDE EDGE LINE
	1155+34.18	1163+43.35	N.B.L. O/S	809.17	EXISTING OUTSIDE EDGE LINE
	1156+04.81	1178+52.72	N.B.L. CL	561.98	EXISTING INTERMITTENT LANE LINE
PRIOR TO OUTSIDE LANE CLOSURE	1139+05.40	1178+52.72	VARIES	6117.56	TEMPORARY PAVEMENT MARKING FROM INSIDE LANE CLOSURE
	1154+14.78	1157+76.31	S.B.L. I/S	361.53	EXISTING INSIDE EDGE LINE
	1155+34.18	1157+60.72	N.B.L. I/S	226.54	EXISTING INSIDE EDGE LINE
	1159+81.81	1163+43.35	N.B.L. I/S	361.54	EXISTING INSIDE EDGE LINE
PRIOR TO PERMANENT PAVEMENT MARKING	1159+97.40	1162+23.94	S.B.L. I/S	226.54	EXISTING INSIDE EDGE LINE
	1139+05.40	1178+52.72	VARIES	6258.82	TEMPORARY PAVEMENT MARKING FROM OUTSIDE LANE CLOSURE
TOTAL				16294.82	
PAY TOTAL				16295	

CLASS B CONCRETE			
STATION	LOCATION	DESCRIPTION	CLASS B CONC. (MISC.) (CU. YD.)
1158+14.40	S.B.L.	EROSION/UNDERMINING AT END BENT	8.00
TOTAL			8.00
PAY TOTAL			8.0

RUMBLE STRIPS				
STATION	STATION	LOCATION	LENGTH (FT.)	SHOULDER RUMBLE STRIPS (STA.)
1154+06.23	1157+76.31	S.B.L. O/S	370.08	3.70
1154+06.23	1157+76.31	S.B.L. I/S	370.08	3.70
1155+25.72	1157+60.72	N.B.L. I/S	235.00	2.35
1155+25.72	1157+60.72	N.B.L. O/S	235.00	2.35
1159+84.74	1163+51.90	N.B.L. O/S	367.16	3.67
1159+91.71	1163+51.90	N.B.L. I/S	360.19	3.60
1160+00.34	1162+32.41	S.B.L. I/S	232.07	2.32
1160+07.30	1162+32.41	S.B.L. O/S	225.11	2.25
TOTAL			23.94	
PAY TOTAL			23.9	

TEMPORARY PAVEMENT MARKING						
STAGE	STATION	STATION	LOCATION	TEMPORARY REMOVABLE MARKING TAPE		REMARKS
				4 IN. WHITE (LIN. FT.)	4 IN. YELLOW (LIN. FT.)	
INSIDE LANE CLOSURE	1139+05.40	1161+53.32	S.B.L. I/S		2249.48	INSIDE EDGE LINE
	1154+14.78	1162+23.94	S.B.L. O/S	809.30		OUTSIDE EDGE LINE
	1155+34.18	1163+43.35	N.B.L. O/S	809.30		OUTSIDE EDGE LINE
	1156+04.81	1178+52.72	N.B.L. I/S		2249.48	INSIDE EDGE LINE
OUTSIDE LANE CLOSURE	1139+05.40	1162+23.94	S.B.L. O/S	2320.11		OUTSIDE EDGE LINE
	1154+14.78	1162+23.94	S.B.L. I/S		809.30	INSIDE EDGE LINE
	1155+34.18	1178+52.72	N.B.L. O/S	2320.11		OUTSIDE EDGE LINE
	1155+34.18	1163+43.35	N.B.L. I/S		809.30	INSIDE EDGE LINE
TOTALS			6258.82	6117.56		
PAY TOTALS			6259	6118		

PERMANENT PAVEMENT MARKING						
STATION	STATION	LOCATION	HIGH BUILD WATERBORNE PAVEMENT MARKING PAINT, TYPE L BEADS			
			6 IN. WHITE			6 IN. YELLOW (LIN. FT.)
			SOLID (LIN. FT.)	INTERMITTENT (LIN. FT.)	TOTAL (LIN. FT.)	
1139+05.40	1162+23.94	S.B.L.	2318.54	579.64	2898.18	2318.54
1155+34.18	1178+52.72	N.B.L.	2318.54	579.64	2898.18	2318.54
TOTALS			5796.36		4637.08	
PAY TOTALS			5796		4637	

TEMPORARY EROSION CONTROL						
STATION	STATION	LOCATION	ROCK DITCH CHECK (LIN. FT.)	SEDIMENT REMOVAL (CU. YD.)	SILT FENCE (LIN. FT.)	REMARKS
1153+96.00	1158+10.00	S.B.L. O/S		4.2	424.0	
1157+75.00	--	N.B.L. O/S	20.0	1.0		
1157+80.00	--	MEDIAN	50.0	1.0		INLET CHECK
1158+05.00	1158+66.00	MEDIAN		2.7	267.0	
1158+25.00	--	N.B.L. O/S	20.0	1.0		
1158+92.00	1159+75.00	MEDIAN		3.0	304.0	
1162+42.00	--	S.B.L. O/S	20.0	1.0		
1162+92.00	--	S.B.L. O/S	20.0	1.0		
1163+62.00	--	MEDIAN	20.0	1.0		
1163+62.00	--	N.B.L. O/S	20.0	1.0		
1164+12.00	--	MEDIAN	20.0	1.0		
1164+12.00	--	N.B.L. O/S	20.0	1.0		
TOTALS			210.0	18.9	995.0	
PAY TOTALS			210	19	995	

SEEDING AND MULCH						
STATION	STATION	LOCATION	LENGTH (FT.)	ESTIMATED WIDTH (FT.)	MULCHING (ACRE)	SEEDING COOL SEASON GRASSES (ACRE)
1153+96.00	1158+10.00	S.B.L. O/S	414.00	10.00	0.10	0.10
1153+96.00	1158+03.00	S.B.L. MEDIAN	407.00	10.00	0.09	0.09
1155+16.00	1157+96.00	N.B.L. MEDIAN	280.00	10.00	0.06	0.06
1155+16.00	1157+88.00	N.B.L. O/S	272.00	10.00	0.06	0.06
1159+48.00	1161+35.00	N.B.L. O/S	187.00	VARIES	0.15	0.15
1159+55.00	1161+35.00	N.B.L. MEDIAN	180.00	24.00	0.10	0.10
1159+59.00	1161+35.00	S.B.L. MEDIAN	176.00	24.00	0.10	0.10
1159+70.00	1161+35.00	S.B.L. O/S	165.00	VARIES	0.11	0.11
1161+35.00	1163+62.00	N.B.L. O/S	227.00	10.00	0.05	0.05
1161+35.00	1163+62.00	N.B.L. MEDIAN	227.00	10.00	0.05	0.05
1161+35.00	1162+42.00	S.B.L. MEDIAN	107.00	10.00	0.02	0.02
1161+35.00	1162+42.00	S.B.L. O/S	107.00	10.00	0.02	0.02
TOTALS					0.91	0.91
PAY TOTALS					1.0	1.0

SUMMARY OF QUANTITIES
SHEET 2 OF 3

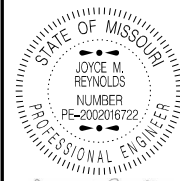

DATE PREPARED
10/09/2024 8:32:42 AM
JOYCE M. REYNOLDS - CIVIL
MO-PE-2002016722

10/7/2024

ROUTE STATE
I - 29 MO
DISTRICT SHEET NO.
NW 3

COUNTY
ATCHISON

J113280

CONTRACT ID.

PROJECT NO.

BRIDGE NO.

Table with 2 columns: DATE, DESCRIPTION

DATE

DESCRIPTION

MISSOURI HIGHWAYS AND TRANSPORTATION COMMISSION

105 WEST CAPITOL JEFFERSON CITY, MO 65102



1-888-ASK-MODOT (1-888-275-6636)

Table with columns: SIGN, SIZE, AREA, QTY, TOTAL AREA, QTY RELOC, TOTAL RELOC, SIGN NUM., DESCRIPTION

Table with columns: SIGN, SIZE, AREA, QTY, TOTAL, RELOC, SIGN NUM., DESCRIPTION

Table with columns: ITEM NUMBER, TOTAL QTY, DESCRIPTION

* NOT INCLUDED IN MISC. LUMP SUM TEMPORARY TRAFFIC CONTROL

616-99.01 - MISC. LUMP SUM TEMPORARY TRAFFIC CONTROL
1 LUMP SUM

NOTES: ALL TEMPORARY TRAFFIC CONTROL ITEMS ARE INCLUDED IN PAY ITEM 616-99.01, MISC. LUMP SUM TEMPORARY TRAFFIC CONTROL, UNLESS OTHERWISE NOTED. THE QUANTITIES SHOWN ARE AN ESTIMATE ONLY AND ARE SUBJECT TO CHANGE BASED ON FIELD CONDITIONS.

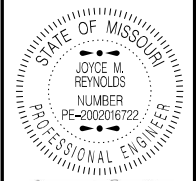

DATE PREPARED
10/7/2024

ROUTE I-29 STATE MO
DISTRICT NW SHEET NO. 7

COUNTY ATCHISON
JOB NO. J113280
CONTRACT ID.

PROJECT NO.
BRIDGE NO.

DATE	DESCRIPTION

MISSOURI HIGHWAYS AND TRANSPORTATION COMMISSION

 105 WEST CAPITOL
 JEFFERSON CITY, MO 65102
 1-888-ASK-MODOT (1-888-275-6636)

1159

1160

1161

1162

1163

1164

MATCHLINE STA. 1158+80.00

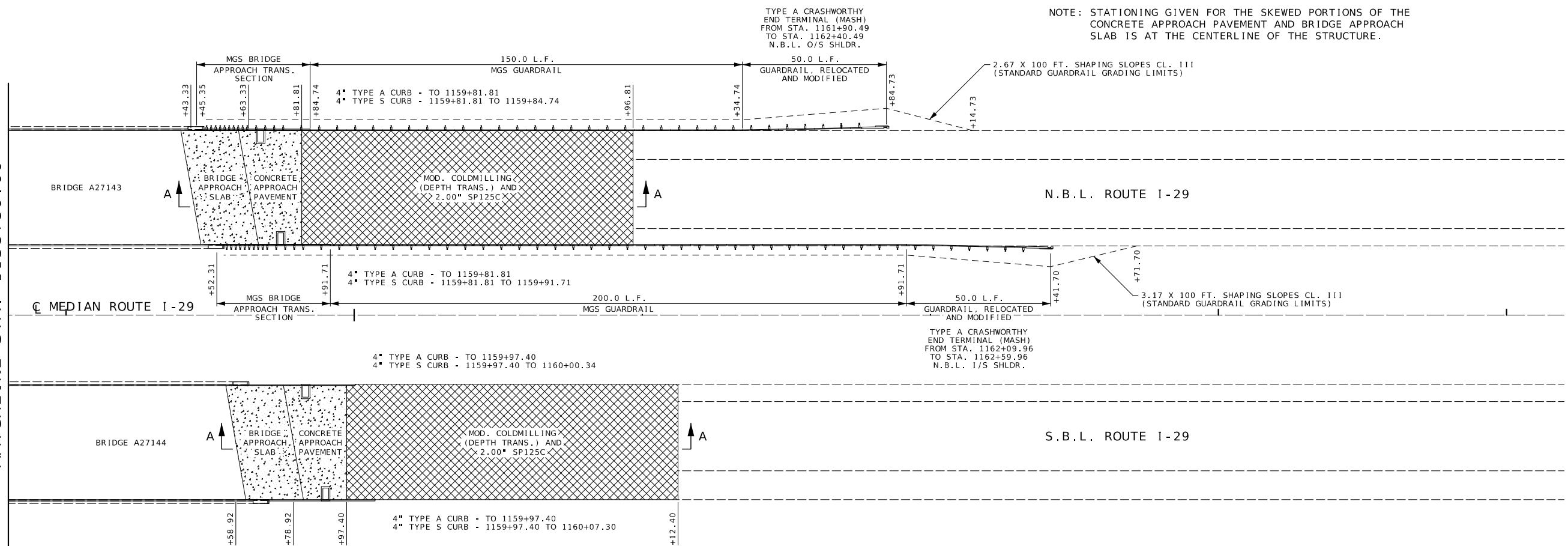

TYPE A CRASHWORTHY END TERMINAL (MASH) FROM STA. 1161+90.49 TO STA. 1162+40.49 N.B.L. O/S SHLDR.

NOTE: STATIONING GIVEN FOR THE SKEWED PORTIONS OF THE CONCRETE APPROACH PAVEMENT AND BRIDGE APPROACH SLAB IS AT THE CENTERLINE OF THE STRUCTURE.

TYPE A CRASHWORTHY END TERMINAL (MASH) FROM STA. 1162+09.96 TO STA. 1162+59.96 N.B.L. I/S SHLDR.

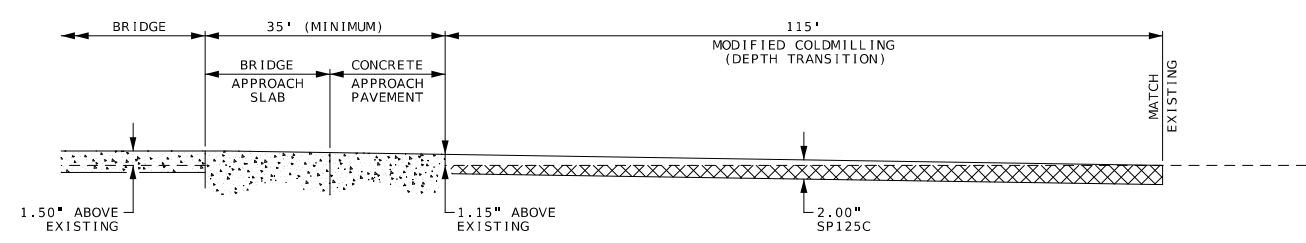

STA. 1159+45.35 TO STA. 1161+84.73
 N.B.L. ROUTE I-29, OUTSIDE SHOULDER
 BUILD 1-MGS BRIDGE APPROACH TRANSITION SECTION (EXTENDED CURB)
 150.0 L.F. MGS GUARDRAIL
 50.0 L.F. GUARDRAIL, RELOCATED AND MODIFIED (TYPE A CRASHWORTHY END TERMINAL (MASH))

STA. 1159+52.31 TO STA. 1162+41.70
 N.B.L. ROUTE I-29, INSIDE SHOULDER
 BUILD 1-MGS BRIDGE APPROACH TRANSITION SECTION (EXTENDED CURB)
 200.0 L.F. MGS GUARDRAIL
 50.0 L.F. GUARDRAIL, RELOCATED AND MODIFIED (TYPE A CRASHWORTHY END TERMINAL (MASH))

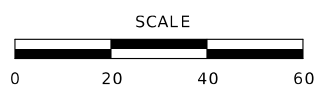

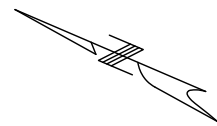

1154

1155

1156

1157

1158

N.B.L. ROUTE I-29

CL MEDIAN ROUTE I-29

S.B.L. ROUTE I-29

250.00'
 BUILD 2.50 X 100 FT. SHOULDER GRADING
 277.8 S.Y. TYPE 5 AGGREGATE FOR BASE
 277.78 S.Y. OPTIONAL PAVEMENT

OBLIT. - 278 S.Y.
 EXIST. SHOULDER

OBLIT. - 167 S.Y.
 EXIST. SHOULDER

EXISTING BRIDGE APPROACH SLAB

BRIDGE A27143

250.00'
 BUILD 2.50 X 100 FT. SHOULDER GRADING
 166.7 S.Y. TYPE 5 AGGREGATE FOR BASE
 166.67 S.Y. OPTIONAL PAVEMENT

6"
 INSIDE SHOULDER

10"
 OUTSIDE SHOULDER

385.00'
 BUILD 3.85 X 100 FT. SHOULDER GRADING
 256.7 S.Y. TYPE 5 AGGREGATE FOR BASE
 256.67 S.Y. OPTIONAL PAVEMENT

OBLIT. - 257 S.Y.
 EXIST. SHOULDER

OBLIT. - 428 S.Y.
 EXIST. SHOULDER

EXISTING BRIDGE APPROACH SLAB

BRIDGE A27144

385.00'
 BUILD 3.85 X 100 FT. SHOULDER GRADING
 427.8 S.Y. TYPE 5 AGGREGATE FOR BASE
 427.78 S.Y. OPTIONAL PAVEMENT

MATCHLINE STA. 1158+80.00

NOTE: SHOULDERS THAT WILL RECEIVE TRAFFIC (AS SHOWN ON THE TRAFFIC CONTROL PLAN) SHALL BE RECONSTRUCTED PRIOR TO THE SHIFTING OF TRAFFIC ONTO THE SHOULDER.

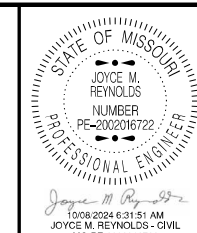
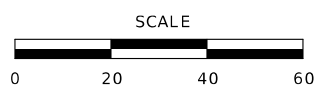

DATE PREPARED	10/7/2024
ROUTE	I-29
STATE	MO
DISTRICT	NW
SHEET NO.	8
COUNTY	ATCHISON
JOB NO.	J113280
CONTRACT ID.	
PROJECT NO.	
BRIDGE NO.	

DATE	DESCRIPTION

MISSOURI HIGHWAYS AND TRANSPORTATION COMMISSION

105 WEST CAPITOL
 JEFFERSON CITY, MO 65102
 1-888-ASK-MODOT (1-888-275-6636)

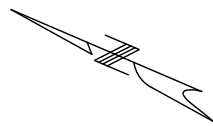

1159

1160

1161

1162

1163

1164

MATCHLINE STA. 1158+80.00

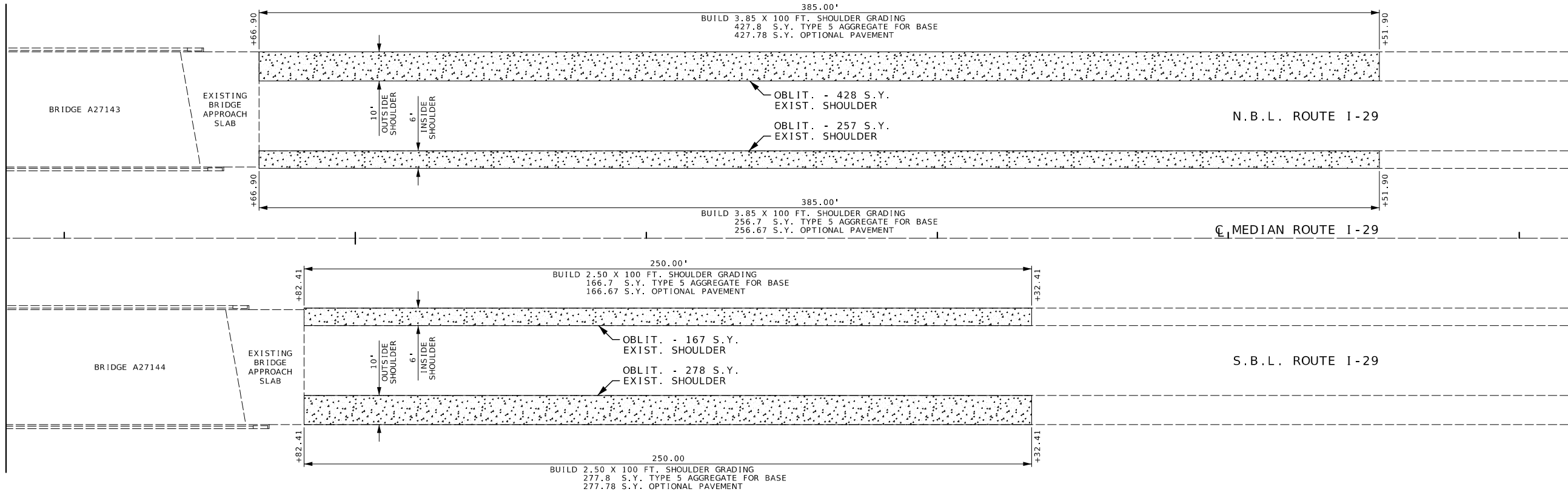

NOTE: SHOULDERS THAT WILL RECEIVE TRAFFIC (AS SHOWN ON THE TRAFFIC CONTROL PLAN) SHALL BE RECONSTRUCTED PRIOR TO THE SHIFTING OF TRAFFIC ONTO THE SHOULDER.

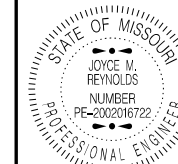
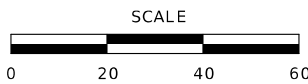

DATE PREPARED
10/7/2024

ROUTE STATE
I - 29 MO
DISTRICT SHEET NO.
NW 9

COUNTY
ATCHISON
JOB NO.
J113280
CONTRACT ID.

PROJECT NO.

BRIDGE NO.

DATE	DESCRIPTION

MISSOURI HIGHWAYS AND TRANSPORTATION
COMMISSION

105 WEST CAPITOL
JEFFERSON CITY, MO 65102
1-888-ASK-MODOT (1-888-275-6636)

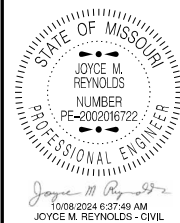

DATE PREPARED
10/7/2024

ROUTE I-29 STATE MO

DISTRICT NW SHEET NO. 10

COUNTY ATCHISON

JOB NO. J113280

CONTRACT ID.

PROJECT NO.

BRIDGE NO.

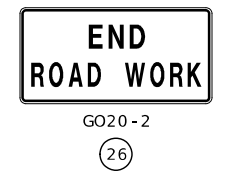
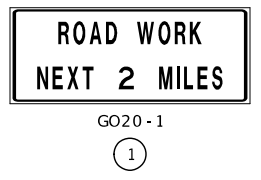

SIGN 57 SHALL BE PLACED IN A VISIBLE AREA WITHIN THE PROJECT LIMITS PROVIDED ITS LOCATION DOES NOT DISRUPT A SEQUENCE OF SIGNS. IF A VISIBLE LOCATION WITHIN THE PROJECT LIMITS IS NOT AVAILABLE, THE SIGN MAY BE PLACED 500 FEET BEFORE SIGN 1.

CHANGEABLE MESSAGE SIGN TO BE PLACED AT A LOCATION APPROVED BY THE ENGINEER

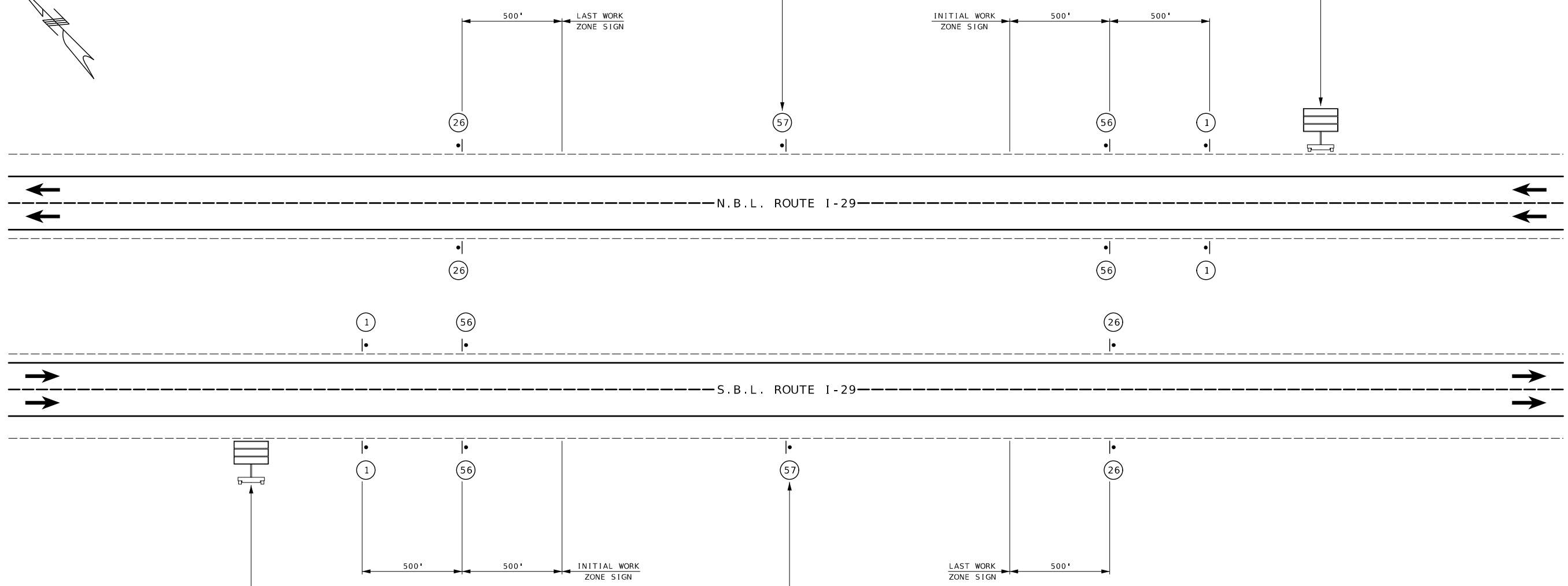
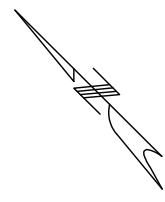

CHANGEABLE MESSAGE SIGN TO BE PLACED AT A LOCATION APPROVED BY THE ENGINEER

SIGN 57 SHALL BE PLACED IN A VISIBLE AREA WITHIN THE PROJECT LIMITS PROVIDED ITS LOCATION DOES NOT DISRUPT A SEQUENCE OF SIGNS. IF A VISIBLE LOCATION WITHIN THE PROJECT LIMITS IS NOT AVAILABLE, THE SIGN MAY BE PLACED 500 FEET BEFORE SIGN 1.

NOT TO SCALE

BEGINNING AND END OF PROJECT

DESCRIPTION	DATE

MISSOURI HIGHWAYS AND TRANSPORTATION COMMISSION

105 WEST CAPITOL JEFFERSON CITY, MO 65102
1-888-ASK-MODOT (1-888-275-6636)

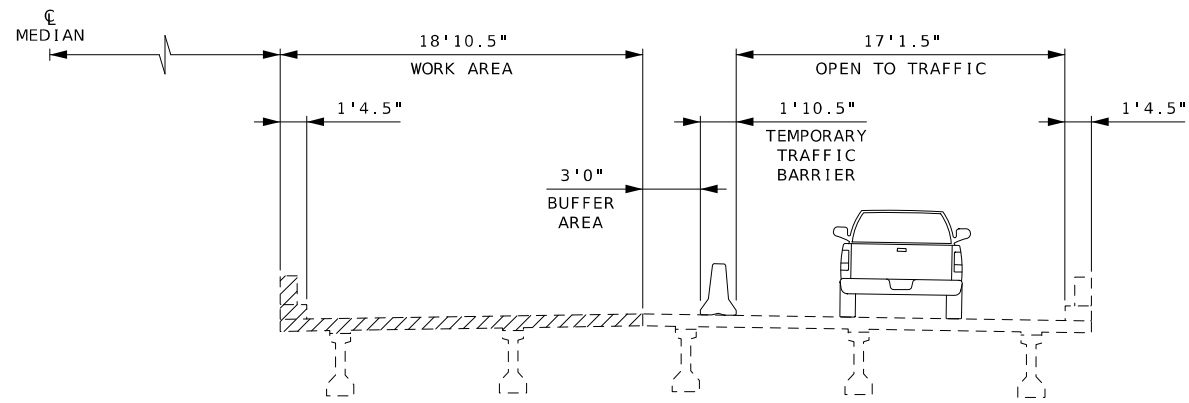

SECTION ON TANGENT
INSIDE (LEFT) LANE CLOSURE WITH
TEMPORARY TRAFFIC BARRIER
SEE SHEETS 13-15

NOTE: SOUTHBOUND BRIDGE SHOWN; NORTHBOUND IS SIMILAR.

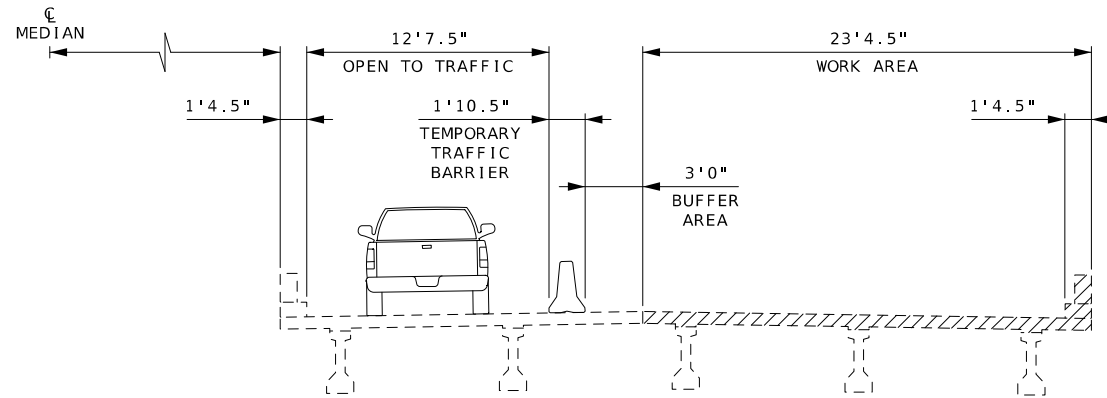

SECTION ON TANGENT
OUTSIDE (RIGHT) LANE CLOSURE WITH
TEMPORARY TRAFFIC BARRIER
SEE SHEETS 16-20

NOT TO SCALE

TYPICAL SECTIONS - LANE CLOSURES WITH TEMPORARY TRAFFIC BARRIER

TRAFFIC CONTROL
SHEET 3 OF 12

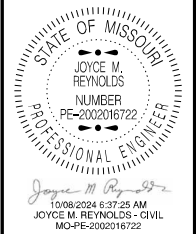

DATE PREPARED
10/7/2024

ROUTE **I - 29** STATE **MO**

DISTRICT **NW** SHEET NO. **12**

COUNTY
ATCHISON

JOB NO.
J113280

CONTRACT ID.

PROJECT NO.

BRIDGE NO.

DESCRIPTION	DATE

MISSOURI HIGHWAYS AND TRANSPORTATION
COMMISSION

105 WEST CAPITOL
JEFFERSON CITY, MO 65102
1-888-ASK-MODOT (1-888-273-6636)



WO20-1
②



R2-1
④



WO20-5
⑤

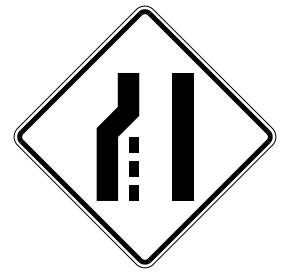

WO4-2L
⑥L



R2-1
②5



GO20-5aP
⑤4



SIGN

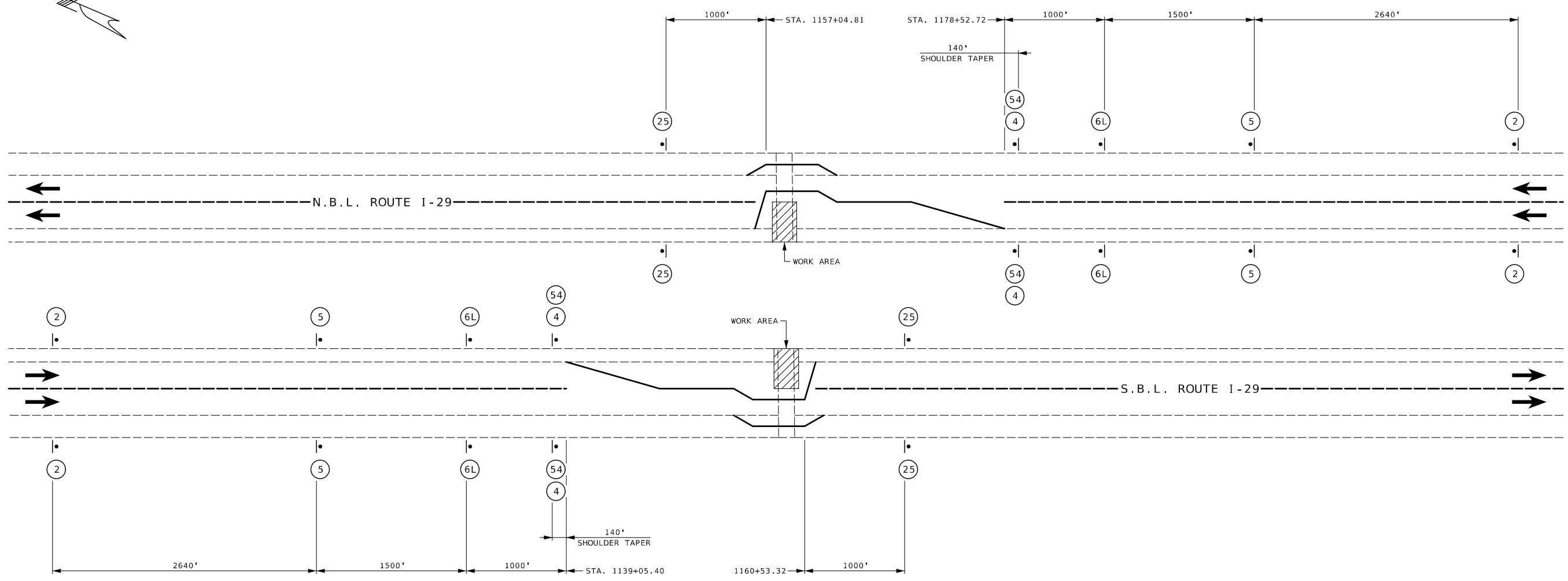
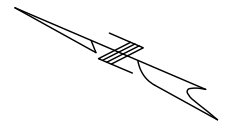

NOT TO SCALE

WORK ON INSIDE (LEFT) LANES - ADVANCE WARNING AND TERMINATION AREA SIGNING

TRAFFIC CONTROL
SHEET 4 OF 12

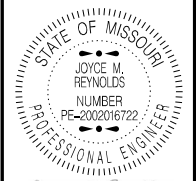

DATE PREPARED
10/7/2024

ROUTE	STATE
I-29	MO
DISTRICT	SHEET NO.
NW	13

COUNTY
ATCHISON
JOB NO.
J113280
CONTRACT ID.

PROJECT NO.
BRIDGE NO.

DESCRIPTION	DATE

MISSOURI HIGHWAYS AND TRANSPORTATION COMMISSION

105 WEST CAPITOL
JEFFERSON CITY, MO 65102
1-888-ASK-MODOT (1-888-275-6636)

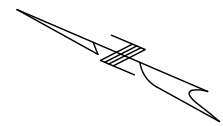

1135

1140

1145

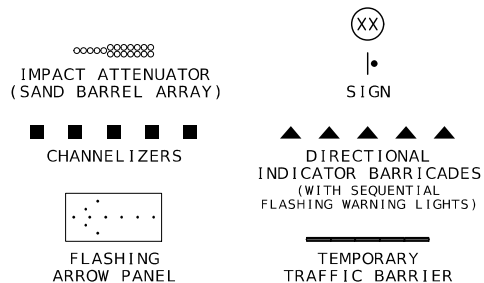
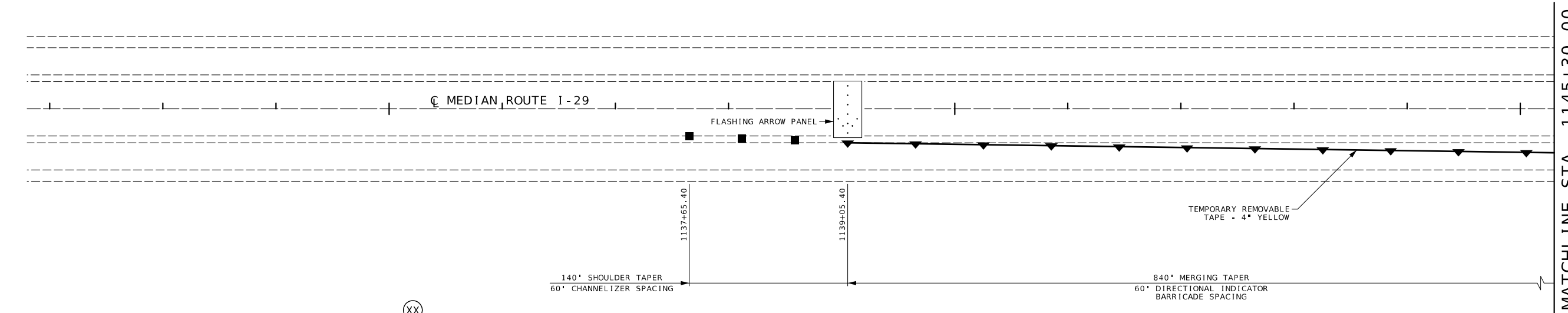

1150

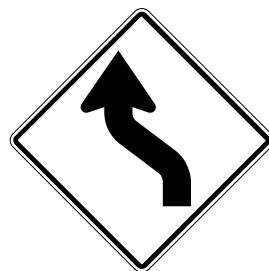
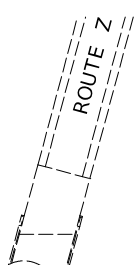

WO1-4L
(15L)

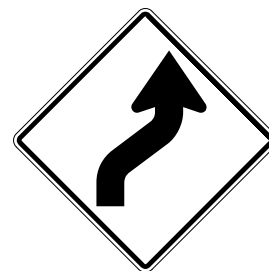

WO1-4R
(15R)

1155

MATCHLINE STA. 1145+30.00

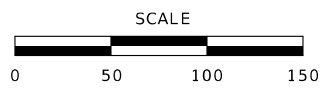

WORK ON INSIDE (LEFT) LANES - TRANSITION AND ACTIVITY AREA DETAILS

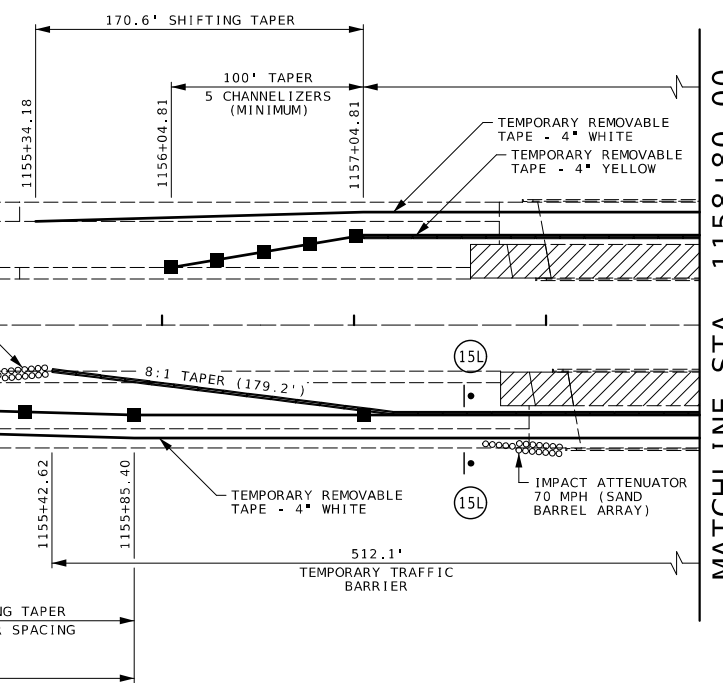

MATCHLINE STA. 1158+80.00

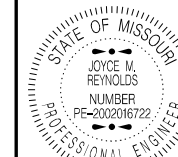

DATE PREPARED
10/7/2024

ROUTE STATE
I-29 MO

DISTRICT SHEET NO.
NW 14

COUNTY
ATCHISON

JOB NO.
J113280

CONTRACT ID.

PROJECT NO.

BRIDGE NO.

DESCRIPTION

DATE

MISSOURI HIGHWAYS AND TRANSPORTATION COMMISSION



105 WEST CAPITOL
JEFFERSON CITY, MO 65102
1-888-ASK-MODOT (1-888-275-6636)

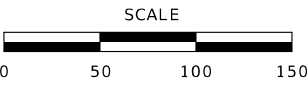
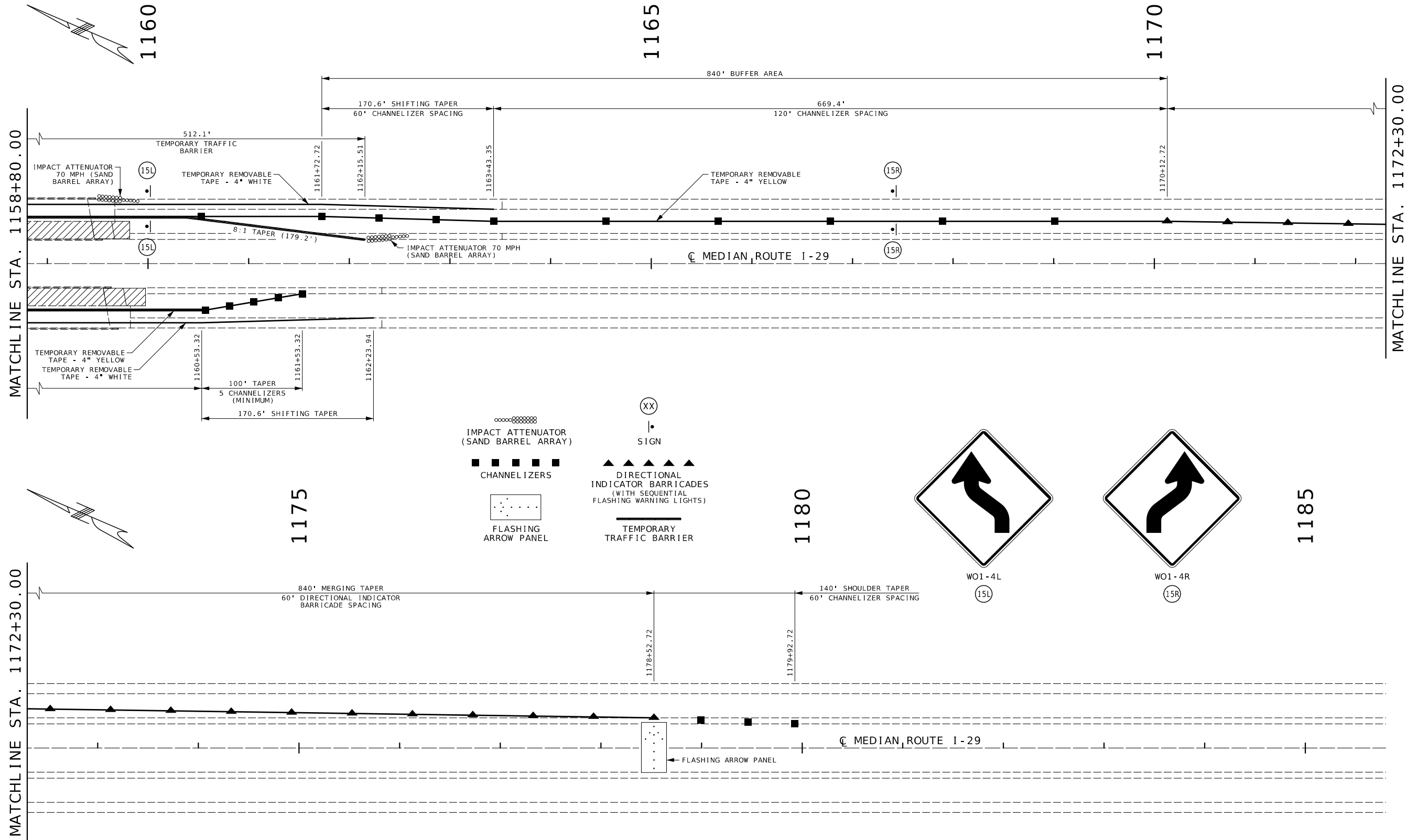

WORK ON INSIDE (LEFT) LANES - TRANSITION AND ACTIVITY AREA DETAILS

TRAFFIC CONTROL
SHEET 6 OF 12

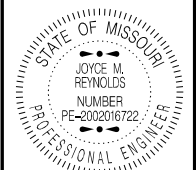

DATE PREPARED
10/7/2024 6:36:55 AM
JOYCE M. REYNOLDS - CIVIL
MC-PE-2002016722

ROUTE I-29 STATE MO
DISTRICT NW SHEET NO. 15

COUNTY ATCHISON
JOB NO. J113280
CONTRACT ID.

PROJECT NO.
BRIDGE NO.

DATE	DESCRIPTION

MISSOURI HIGHWAYS AND TRANSPORTATION COMMISSION
MoDOT
105 WEST CAPITOL
JEFFERSON CITY, MO 65102
1-888-ASK-MODOT (1-888-275-6636)



WO20-1
2



R2-1
4



WO20-5
5

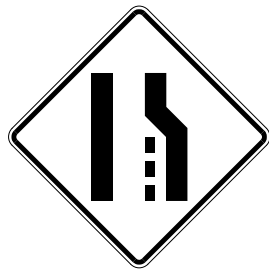

WO4-2R
6R



R2-1
25



WO5-1
43



GO20-5aP
54



SIGN

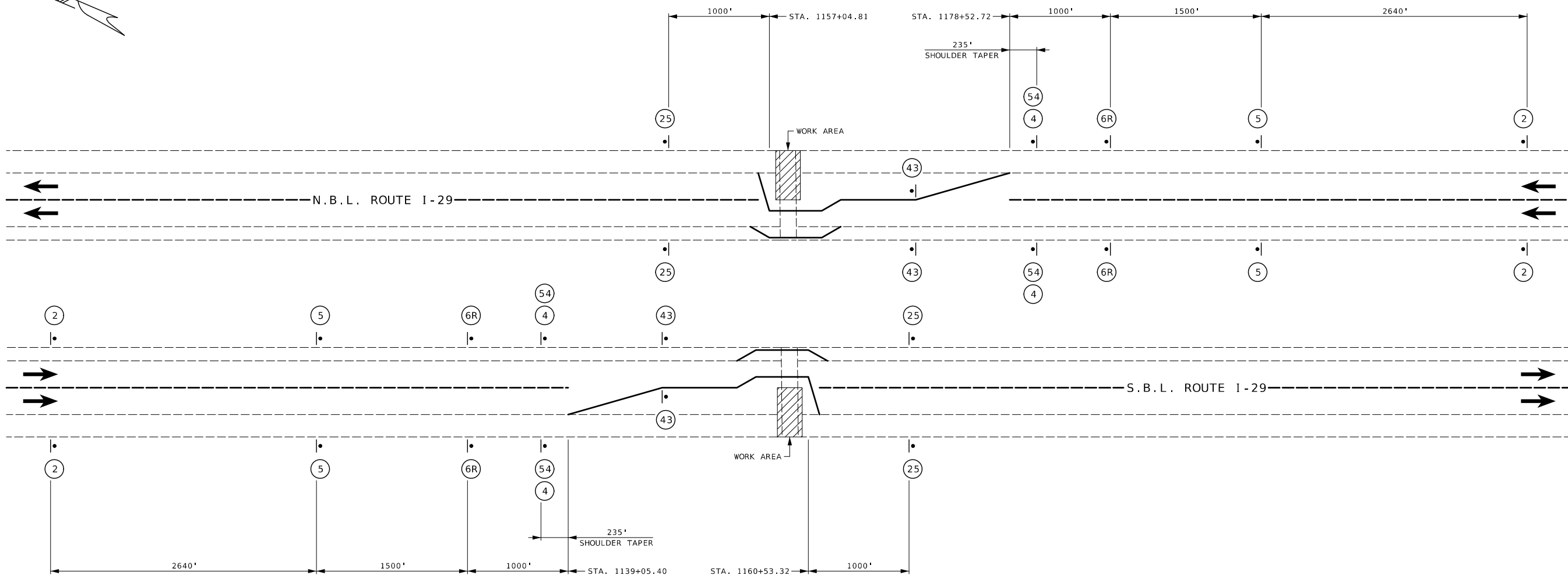
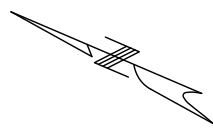

NOT TO SCALE

WORK ON OUTSIDE (RIGHT) LANES - ADVANCE WARNING AND TERMINATION AREA SIGNING

TRAFFIC CONTROL SHEET 7 OF 12

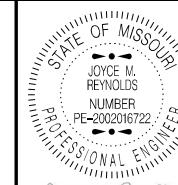

DATE PREPARED
10/7/2024

ROUTE I-29 STATE MO

DISTRICT NW SHEET NO. 16

COUNTY ATCHISON

JOB NO. J113280

CONTRACT ID.

PROJECT NO.

BRIDGE NO.

DATE	DESCRIPTION

MISSOURI HIGHWAYS AND TRANSPORTATION COMMISSION

105 WEST CAPITOL
JEFFERSON CITY, MO 65102
1-888-ASK-MODOT (1-888-275-6636)

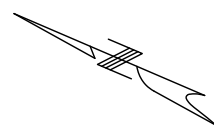

1135

1140

1145

☉ MEDIAN ROUTE 1-29

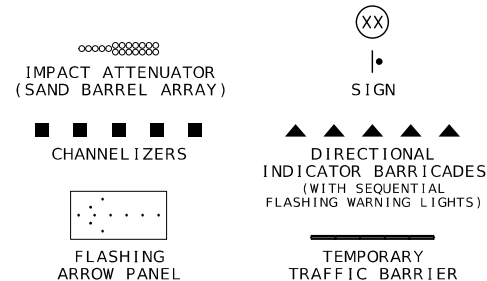
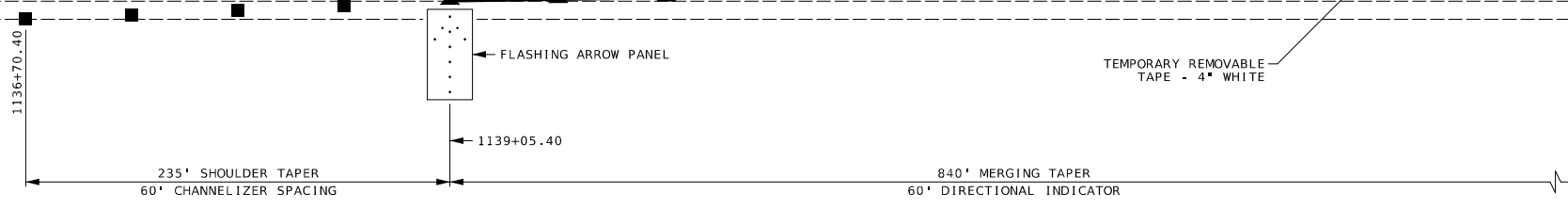

1150

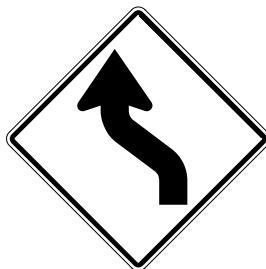
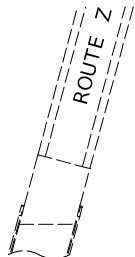

W01-4L (15L)

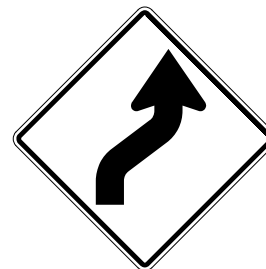

W01-4R (15R)

1155

MATCHLINE STA. 1145+30.00

MATCHLINE STA. 1158+80.00

☉ MEDIAN ROUTE 1-29

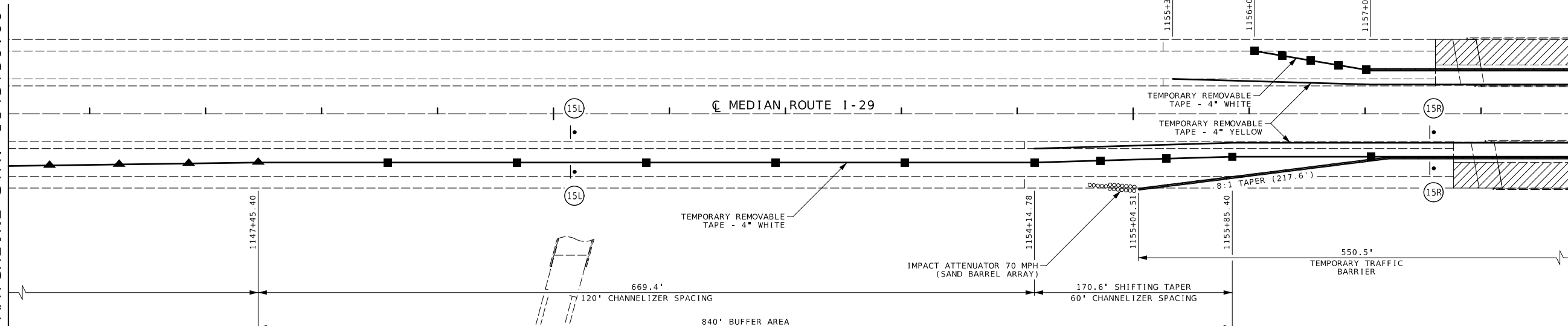

WORK ON OUTSIDE (RIGHT) LANES - TRANSITION AND ACTIVITY AREA DETAILS

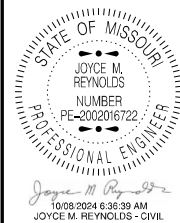

DATE PREPARED
10/7/2024

ROUTE	STATE
I-29	MO
DISTRICT	SHEET NO.
NW	17

COUNTY
ATCHISON

JOB NO.
J113280

CONTRACT ID.

PROJECT NO.

BRIDGE NO.

DATE	DESCRIPTION

MISSOURI HIGHWAYS AND TRANSPORTATION COMMISSION



105 WEST CAPITOL
JEFFERSON CITY, MO 65102
1-888-ASK-MODOT (1-888-275-6636)

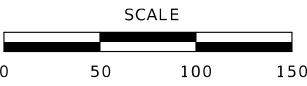
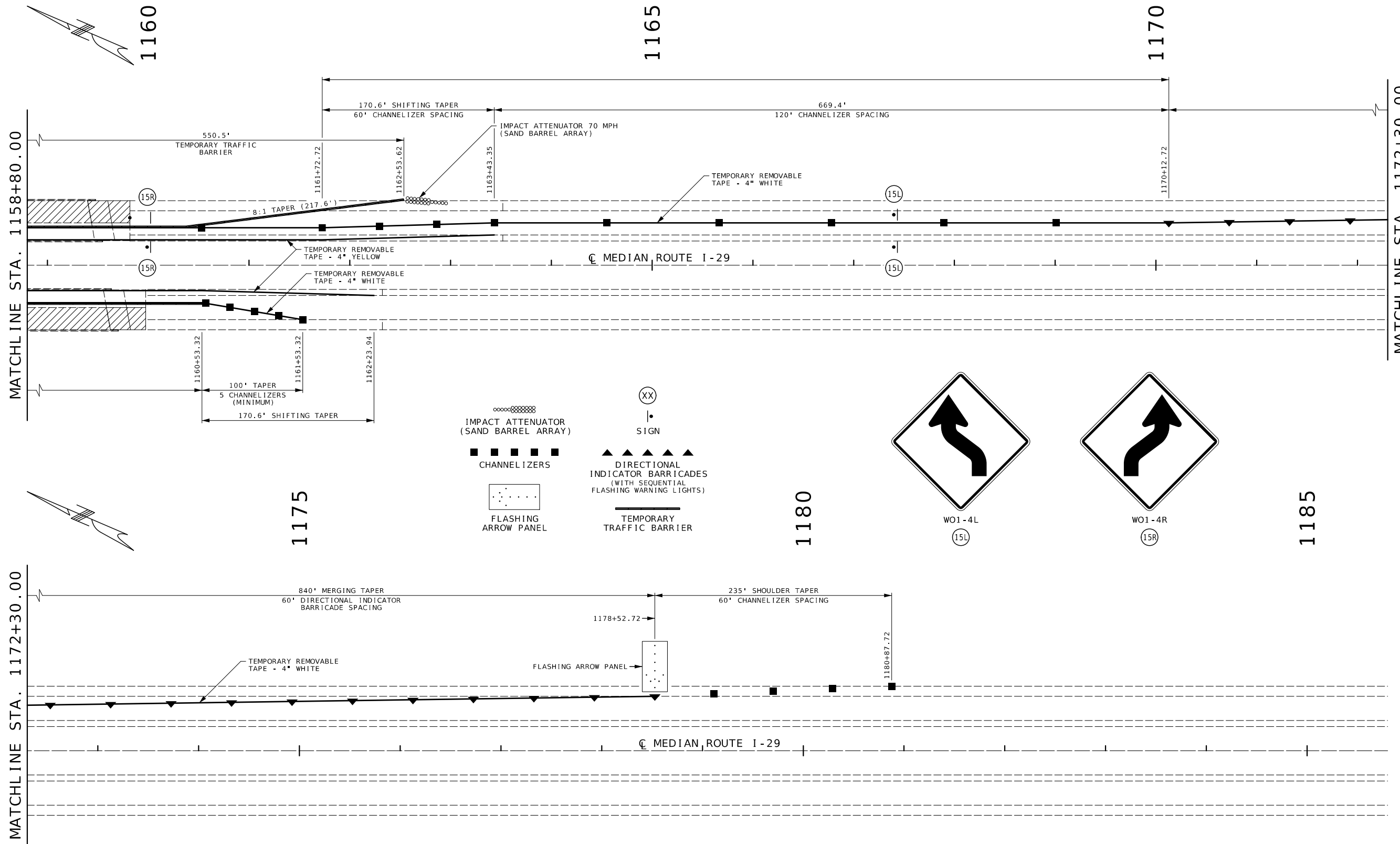

WORK ON OUTSIDE (RIGHT) LANES - TRANSITION AND ACTIVITY AREA DETAILS

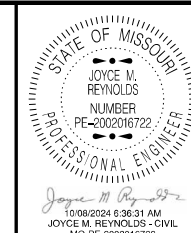

DATE PREPARED
10/7/2024

ROUTE	STATE
I-29	MO
DISTRICT	SHEET NO.
NW	18

COUNTY
ATCHISON

JOB NO.
J113280

CONTRACT ID.

PROJECT NO.

BRIDGE NO.

DATE	DESCRIPTION

MISSOURI HIGHWAYS AND TRANSPORTATION COMMISSION

105 WEST CAPITOL
JEFFERSON CITY, MO 65102
1-888-ASK-MODOT (1-888-275-6636)

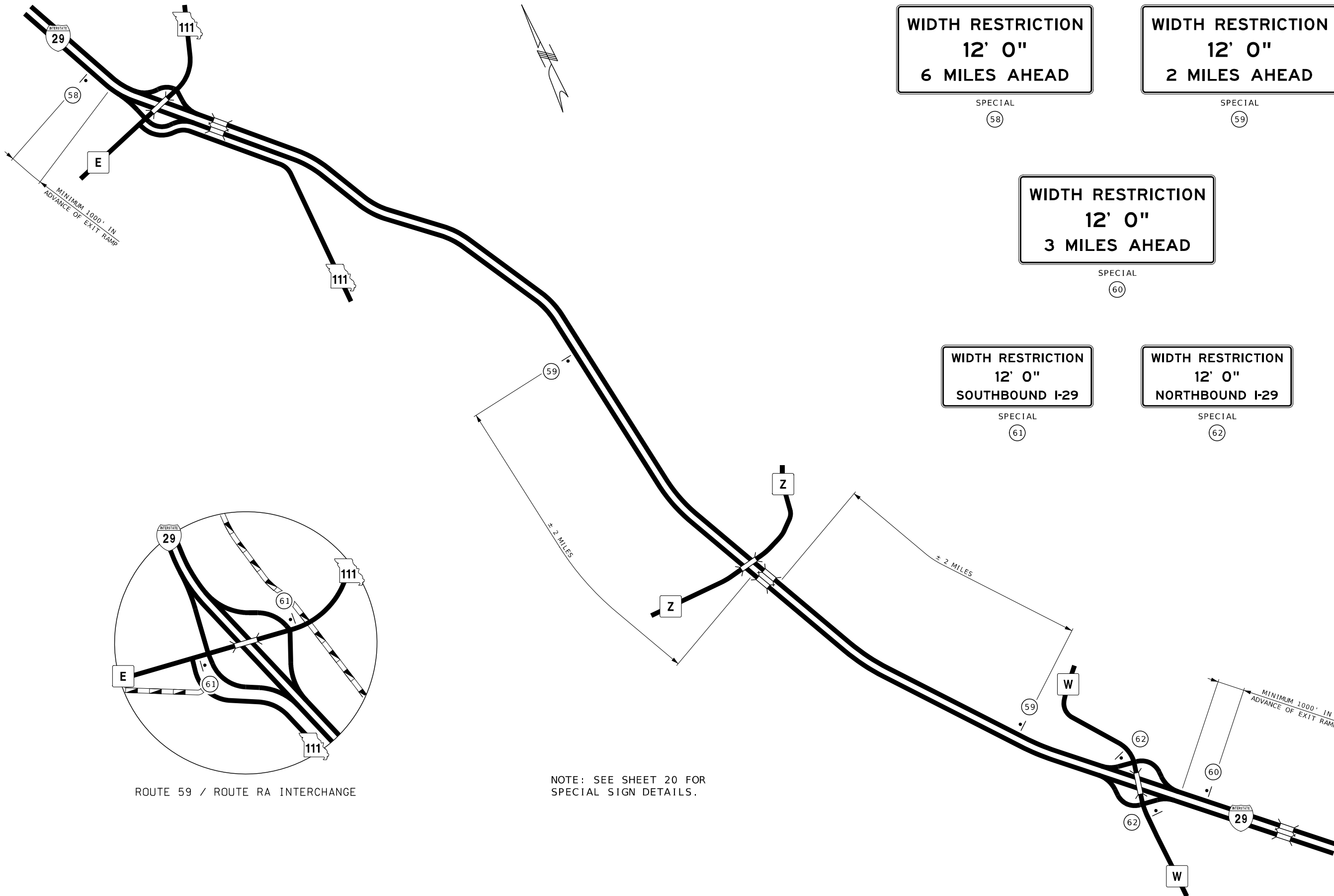

WIDTH RESTRICTION
12' 0"
6 MILES AHEAD

SPECIAL
58

WIDTH RESTRICTION
12' 0"
2 MILES AHEAD

SPECIAL
59

WIDTH RESTRICTION
12' 0"
3 MILES AHEAD

SPECIAL
60

WIDTH RESTRICTION
12' 0"
SOUTHBOUND I-29

SPECIAL
61

WIDTH RESTRICTION
12' 0"
NORTHBOUND I-29

SPECIAL
62

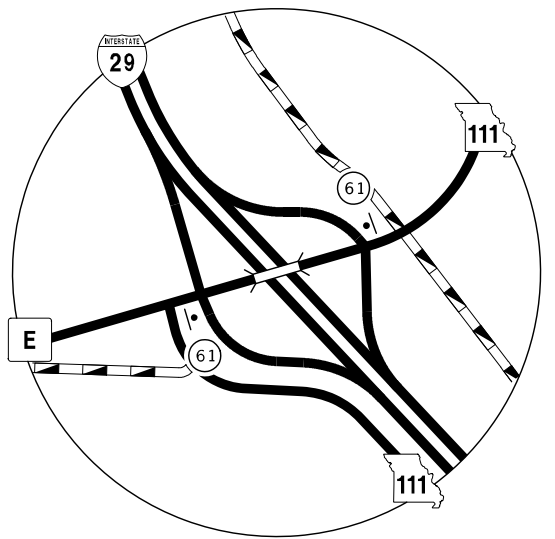

ROUTE 59 / ROUTE RA INTERCHANGE

NOTE: SEE SHEET 20 FOR SPECIAL SIGN DETAILS.

NOT TO SCALE

WORK ON OUTSIDE (RIGHT) LANES - WIDTH RESTRICTION SIGNING

TRAFFIC CONTROL SHEET 10 OF 12

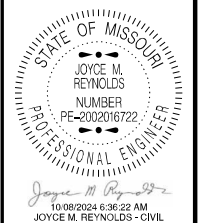

DATE PREPARED
10/7/2024

ROUTE I - 29	STATE MO
DISTRICT NW	SHEET NO. 19
COUNTY ATCHISON	
JOB NO. J113280	
CONTRACT ID.	
PROJECT NO.	
BRIDGE NO.	

DATE	DESCRIPTION

MISSOURI HIGHWAYS AND TRANSPORTATION COMMISSION

105 WEST CAPITOL
JEFFERSON CITY, MO 65102
1-888-ASK-MODOT (1-888-275-6636)

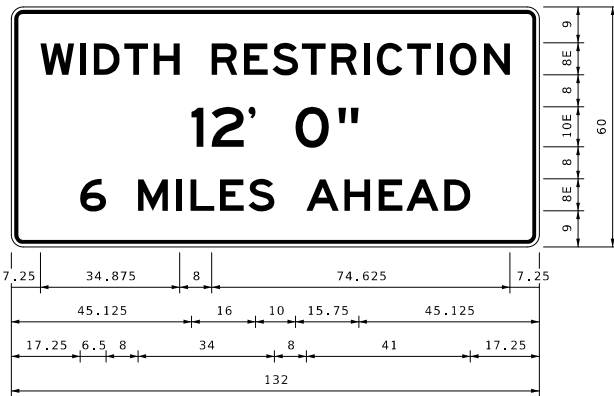

58 SPECIAL

3.000* RADIUS, 1.000* BORDER, 0.750* INDENT, BLACK ON ORANGE;
 [WIDTH] 8E; [RESTRICTION] 8E; [12'] 10E; [0'] 10E;
 [6] 8E; [MILES] 8E; [AHEAD] 8E;

TABLE OF LETTER AND OBJECT LEFTS:

W	I	D	T	H							
7.250	17.125	20.625	28.250	35.625							
R	E	S	T	R	I	C	T	I	O	N	
50.125	58.250	65.375	72.625	80.000	88.125	91.375	99.000	106.375	109.625	118.250	
1	2	'		O	"						
45.125	50.125	59.250		71.125	81.750						
6		M	I	L	E	S					
17.250		31.750	41.250	44.875	52.250	59.250					
A	H	E	A	D							
73.750	83.375	91.875	98.750	108.250							

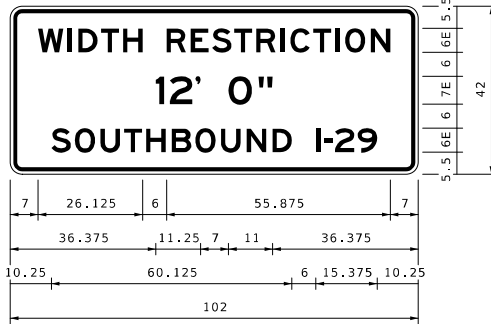

61 SPECIAL

3.000* RADIUS, 1.000* BORDER, 0.750* INDENT, BLACK ON ORANGE;
 [WIDTH] 6E; [RESTRICTION] 6E; [12'] 7E; [0'] 7E;
 [SOUTHBOUND] 6E; [I-29] 6E;

TABLE OF LETTER AND OBJECT LEFTS:

W	I	D	T	H							
7.000	14.375	17.000	22.750	28.250							
R	E	S	T	R	I	C	T	I	O	N	
39.125	45.125	50.500	56.000	61.500	67.625	70.000	75.750	81.250	83.750	90.125	
1	2	'		O	"						
36.375	39.875	46.375		54.625	62.125						
S	O	U	T	H	B	O	U	N	D		
10.250	16.125	22.625	28.500	34.000	40.375	46.250	52.750	59.125	65.500		
I	-	2	9								
76.375	78.500	81.125	86.875								

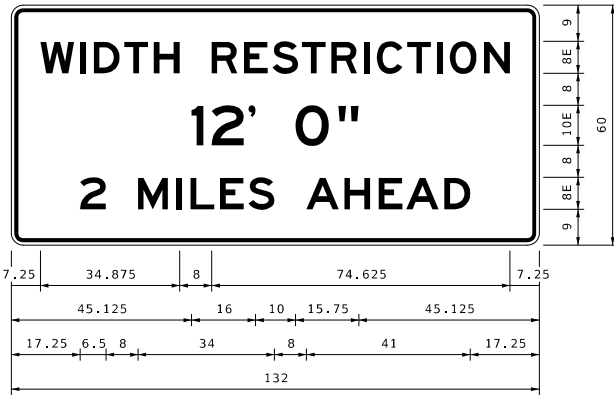

59 SPECIAL

3.000* RADIUS, 1.000* BORDER, 0.750* INDENT, BLACK ON ORANGE;
 [WIDTH] 8E; [RESTRICTION] 8E; [12'] 10E; [0'] 10E;
 [2] 8E; [MILES] 8E; [AHEAD] 8E;

TABLE OF LETTER AND OBJECT LEFTS:

W	I	D	T	H							
7.250	17.125	20.625	28.250	35.625							
R	E	S	T	R	I	C	T	I	O	N	
50.125	58.250	65.375	72.625	80.000	88.125	91.375	99.000	106.375	109.625	118.250	
1	2	'		O	"						
45.125	50.125	59.250		71.125	81.750						
2		M	I	L	E	S					
17.250		31.750	41.250	44.875	52.250	59.250					
A	H	E	A	D							
73.750	83.375	91.875	98.750	108.250							

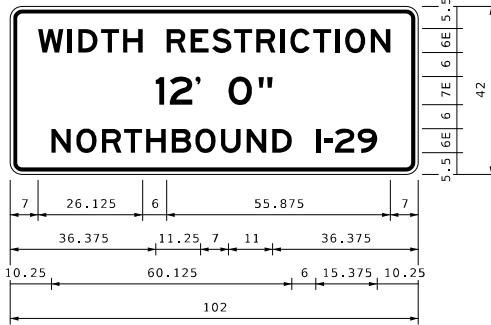

62 SPECIAL

3.000* RADIUS, 1.000* BORDER, 0.750* INDENT, BLACK ON ORANGE;
 [WIDTH] 6E; [RESTRICTION] 6E; [12'] 7E; [0'] 7E;
 [NORTHBOUND] 6E; [I-29] 6E;

TABLE OF LETTER AND OBJECT LEFTS:

W	I	D	T	H							
7.000	14.375	17.000	22.750	28.250							
R	E	S	T	R	I	C	T	I	O	N	
39.125	45.125	50.500	56.000	61.500	67.625	70.000	75.750	81.250	83.750	90.125	
1	2	'		O	"						
36.375	39.875	46.375		54.625	62.125						
N	O	R	T	H	B	O	U	N	D		
10.250	16.500	23.000	28.500	34.000	40.375	46.250	52.750	59.125	65.500		
I	-	2	9								
76.375	78.500	81.125	86.875								

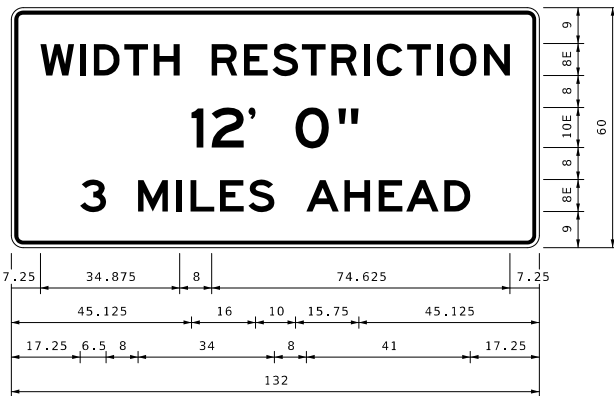

60 SPECIAL

3.000* RADIUS, 1.000* BORDER, 0.750* INDENT, BLACK ON ORANGE;
 [WIDTH] 8E; [RESTRICTION] 8E; [12'] 10E; [0'] 10E;
 [3] 8E; [MILES] 8E; [AHEAD] 8E;

TABLE OF LETTER AND OBJECT LEFTS:

W	I	D	T	H							
7.250	17.125	20.625	28.250	35.625							
R	E	S	T	R	I	C	T	I	O	N	
50.125	58.250	65.375	72.625	80.000	88.125	91.375	99.000	106.375	109.625	118.250	
1	2	'		O	"						
45.125	50.125	59.250		71.125	81.750						
3		M	I	L	E	S					
17.250		31.750	41.250	44.875	52.250	59.250					
A	H	E	A	D							
73.750	83.375	91.875	98.750	108.250							

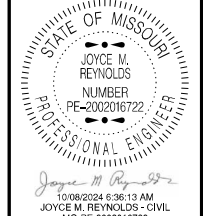

DATE PREPARED
10/7/2024
 ROUTE STATE
I-29 MO
 DISTRICT SHEET NO.
NW 20
 COUNTY
ATCHISON
 JOB NO.
J113280
 CONTRACT ID.

PROJECT NO.
BRIDGE NO.

DATE	DESCRIPTION

MISSOURI HIGHWAYS AND TRANSPORTATION COMMISSION

105 WEST CAPITOL
JEFFERSON CITY, MO 65102
1-888-ASK-MODOT (1-888-275-6636)

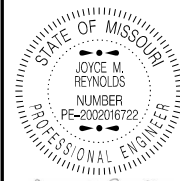

JOYCE M. REYNOLDS
10/08/2024 6:36:04 AM
JOYCE M. REYNOLDS - CIVIL
MO-PE-2002016722

DATE PREPARED
10/7/2024

ROUTE STATE
I - 29 MO

DISTRICT SHEET NO.
NW 21

COUNTY
ATCHISON

JOB NO.
J113280

CONTRACT ID.

PROJECT NO.

BRIDGE NO.

BRIDGE NO.

BRIDGE NO.

BRIDGE NO.

BRIDGE NO.

BRIDGE NO.

BRIDGE NO.

BRIDGE NO.

BRIDGE NO.

BRIDGE NO.

BRIDGE NO.

BRIDGE NO.

BRIDGE NO.

BRIDGE NO.

BRIDGE NO.

BRIDGE NO.

BRIDGE NO.

BRIDGE NO.

BRIDGE NO.

BRIDGE NO.

BRIDGE NO.

BRIDGE NO.

BRIDGE NO.

BRIDGE NO.

BRIDGE NO.

BRIDGE NO.

BRIDGE NO.

BRIDGE NO.

BRIDGE NO.

BRIDGE NO.

BRIDGE NO.

BRIDGE NO.

BRIDGE NO.

BRIDGE NO.

BRIDGE NO.

BRIDGE NO.

BRIDGE NO.

BRIDGE NO.

BRIDGE NO.

BRIDGE NO.

BRIDGE NO.

BRIDGE NO.

BRIDGE NO.

BRIDGE NO.

BRIDGE NO.

BRIDGE NO.

BRIDGE NO.

BRIDGE NO.

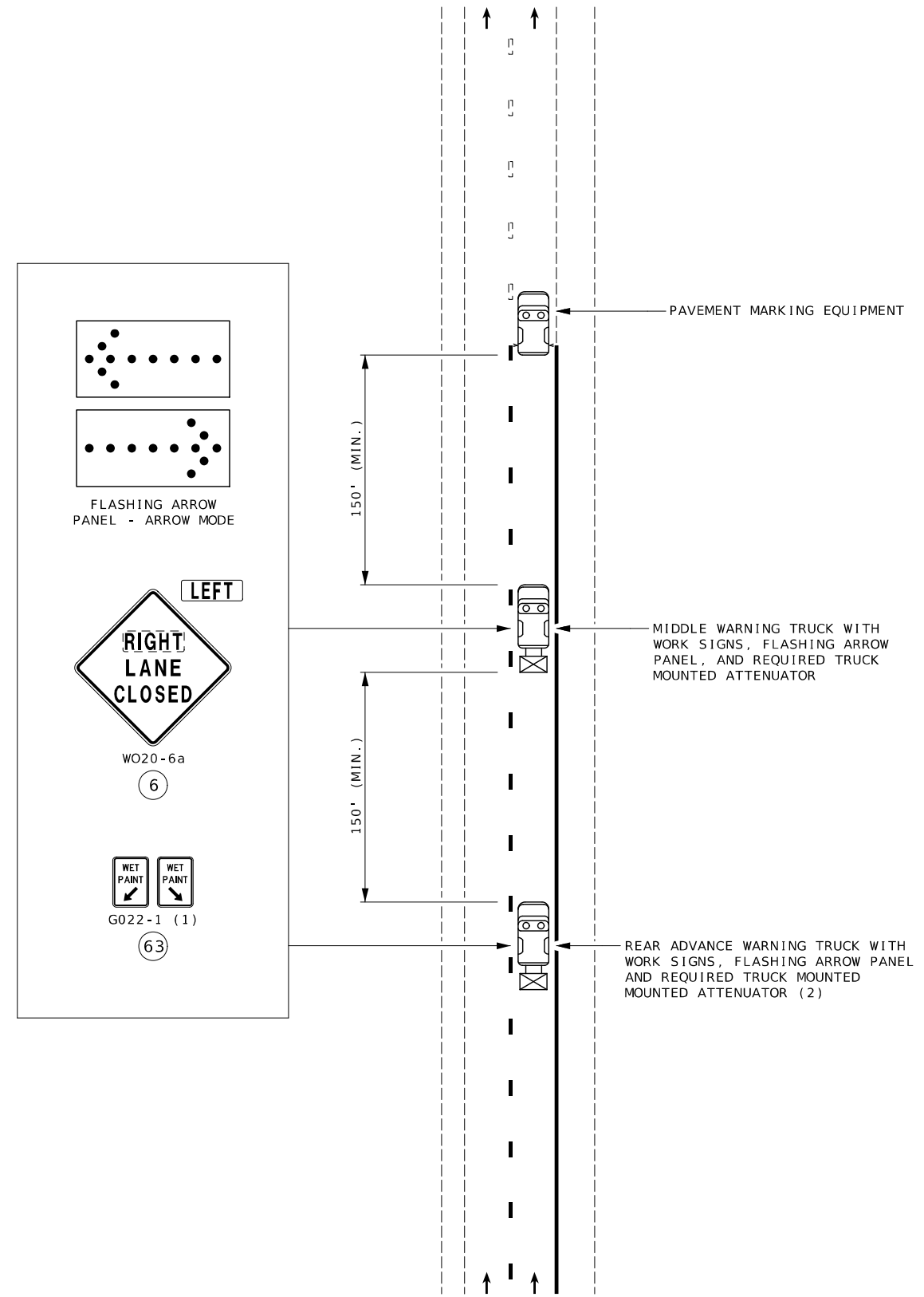

NOTES:

UPON APPROVAL OF THE ENGINEER, THE CONTRACTOR MAY PROVIDE ADDITIONAL PROTECTIVE TRUCKS EQUIPPED WITH PROPER WARNING DEVICES.

PROTECTIVE TRUCK AND WORK VEHICLES SHALL DISPLAY HIGH-INTENSITY ROTATING, FLASHING, OSCILLATING OR STROBE LIGHTS.

VEHICLE HAZARD WARNING SIGNALS SHALL NOT BE USED INSTEAD OF THE VEHICLE'S HIGH-INTENSITY ROTATING, ROTATING, FLASHING, OSCILLATING OR STROBE LIGHTS.

FLASHING ARROW PANELS SHALL BE INCIDENTAL TO TRUCK MOUNTED ATTENUATORS, WHEREVER USED, NO ADDITIONAL PAYMENT WILL BE MADE.

(1) WET PAINT SIGNS ARE INSTALLED TO INDICATE THE SIDE TO WHICH THE PAVEMENT MARKING MATERIAL IS BEING APPLIED. AT THE CONTRACTOR'S OPTION, A FRONT FACING WET PAINT SIGN MAY BE INSTALLED ON THE LEFT SIDE OF THE PAVEMENT MARKING EQUIPMENT.

(2) REAR ADVANCE WARNING TRUCK IS POSITIONED AT THE NO TRACK POINT OF THE PAVEMENT MARKING MATERIAL, OR VERTICAL OR HORIZONTAL CURVES THAT RESTRICT SIGHT DISTANCE, OR SPACING SHOWN.

NOT TO SCALE

MOVING OPERATION - PAVEMENT MARKING

MISSOURI HIGHWAYS AND TRANSPORTATION COMMISSION



105 WEST CAPITOL JEFFERSON CITY, MO 65102 1-888-ASK-MODOT (1-888-275-6636)

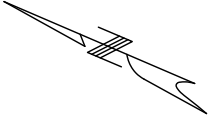

KEY TO SYMBOLS

- ROCK DITCH CHECK
- INLET CHECK
- SILT FENCE
- SEEDING AND MULCH

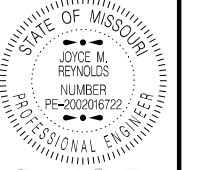

DATE PREPARED
10/7/2024

ROUTE	STATE
I - 29	MO
DISTRICT	SHEET NO.
NW	22

COUNTY
ATCHISON

JOB NO.
J113280

CONTRACT ID.

PROJECT NO.

BRIDGE NO.

1155

1160

1165

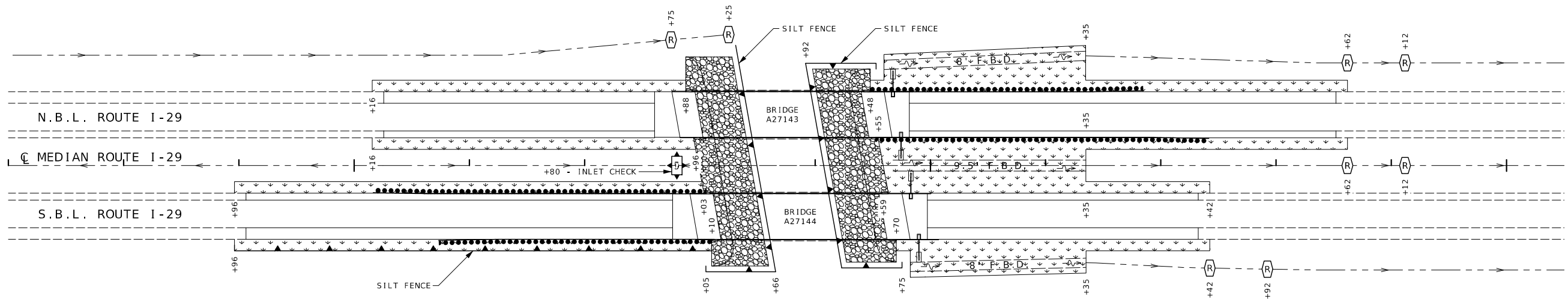

DATE	DESCRIPTION

MISSOURI HIGHWAYS AND TRANSPORTATION COMMISSION

MoDOT

105 WEST CAPITOL
JEFFERSON CITY, MO 65102
1-888-ASK-MODOT (1-888-275-6636)

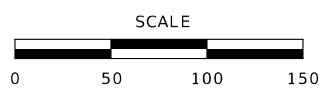

NOTES: ELEVATIONS ON THIS SHEET ARE APPROXIMATE AND MAY DIFFER FROM FIELD ELEVATIONS.
 HATCHING INDICATES AREA OF CLASS 3 EXCAVATION.

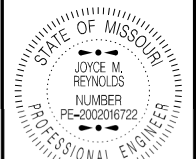

DATE PREPARED
 10/7/2024

ROUTE	STATE
I-29	MO
DISTRICT	SHEET NO.
NW	23

COUNTY
ATCHISON
JOB NO.
J113280
CONTRACT ID.

PROJECT NO.
BRIDGE NO.

DATE	DESCRIPTION

MISSOURI HIGHWAYS AND TRANSPORTATION COMMISSION

105 WEST CAPITOL
 JEFFERSON CITY, MO 65102
 1-888-ASK-MODOT (1-888-275-6636)

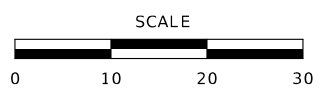
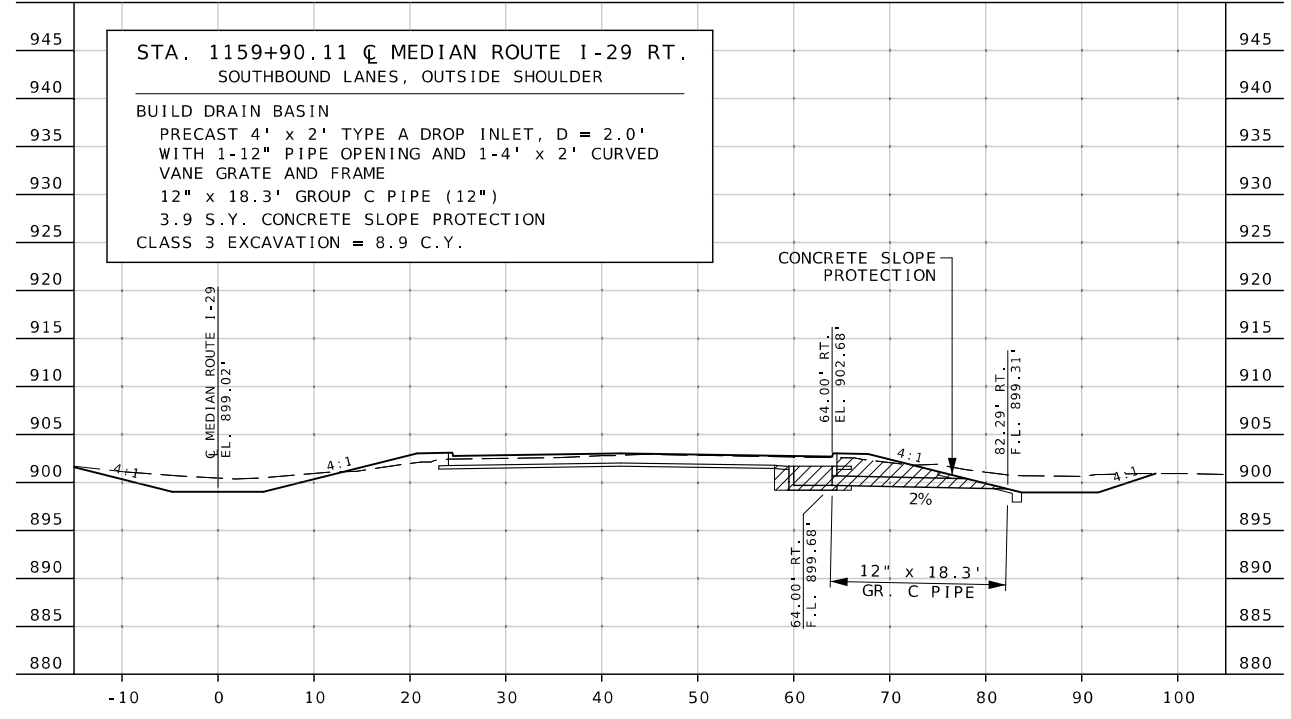
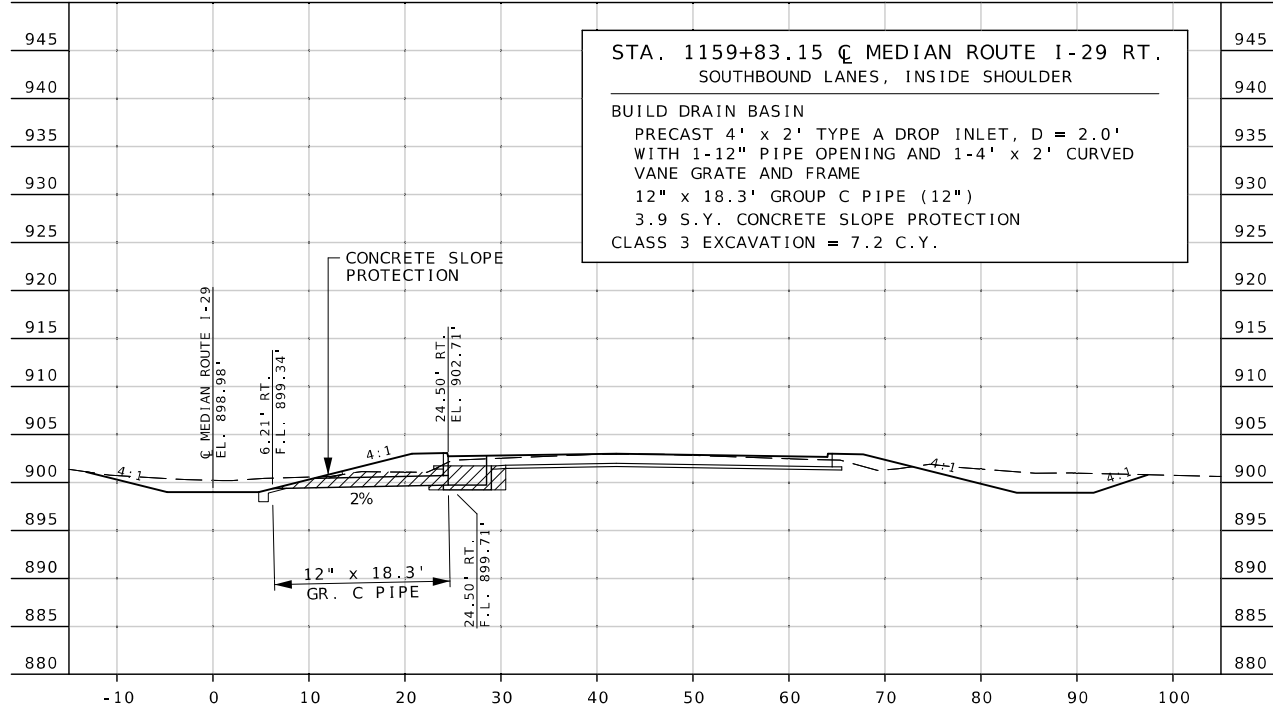
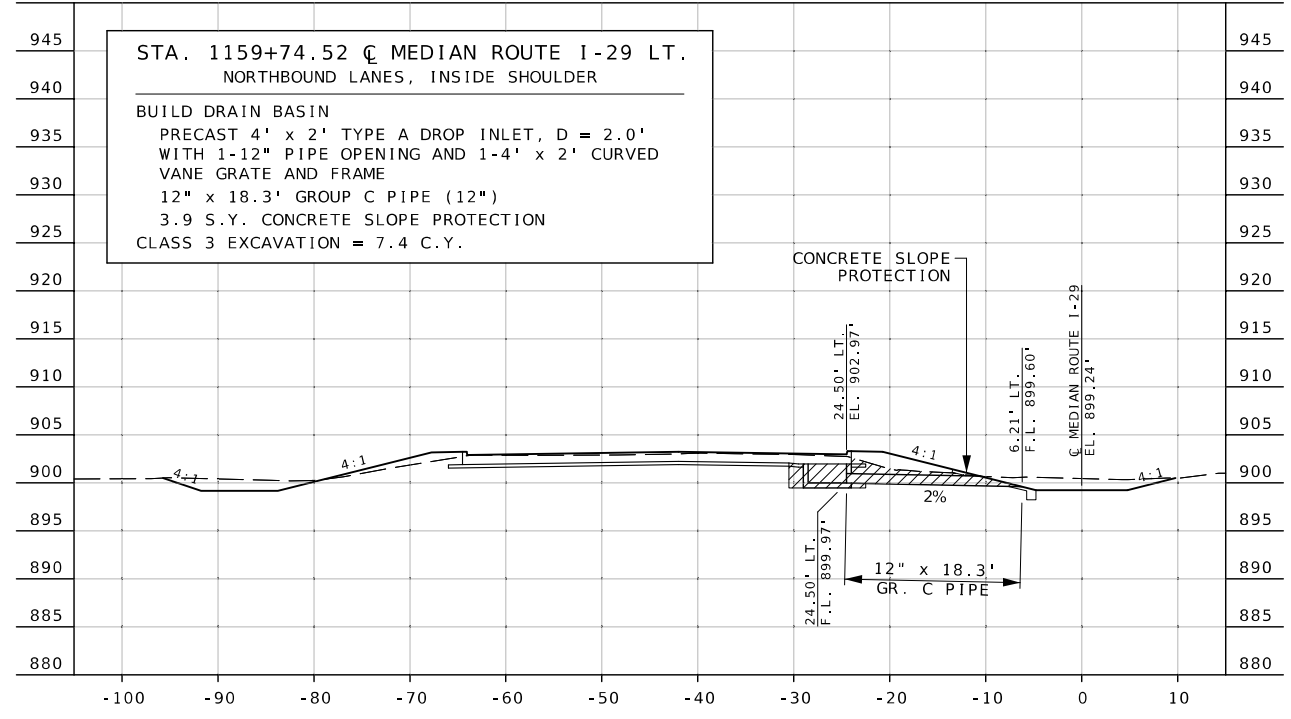
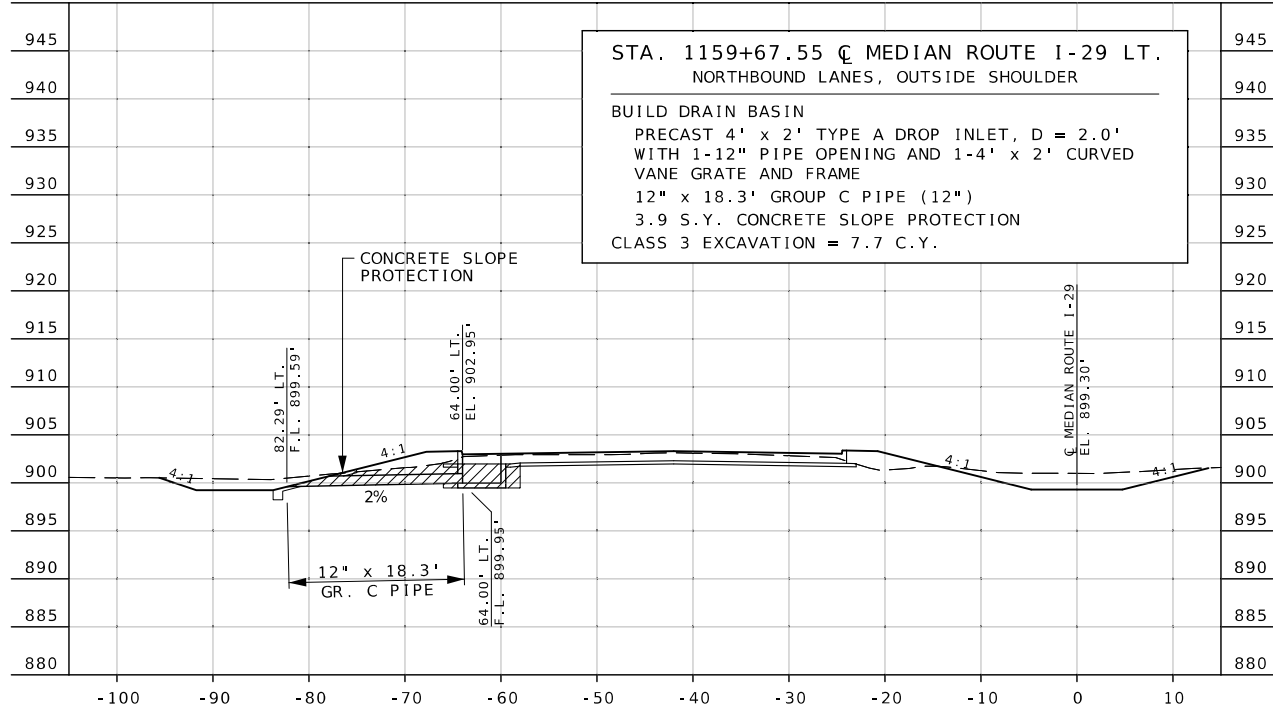

U.I.P. AND REHABILITATE EXISTING (43'-57'-43') PRESTRESSED CONCRETE I-GIRDER SPANS
(SKEW: 10°00'00" R.A.)

SEC/SUR 2 TWP 63N RGE 41W

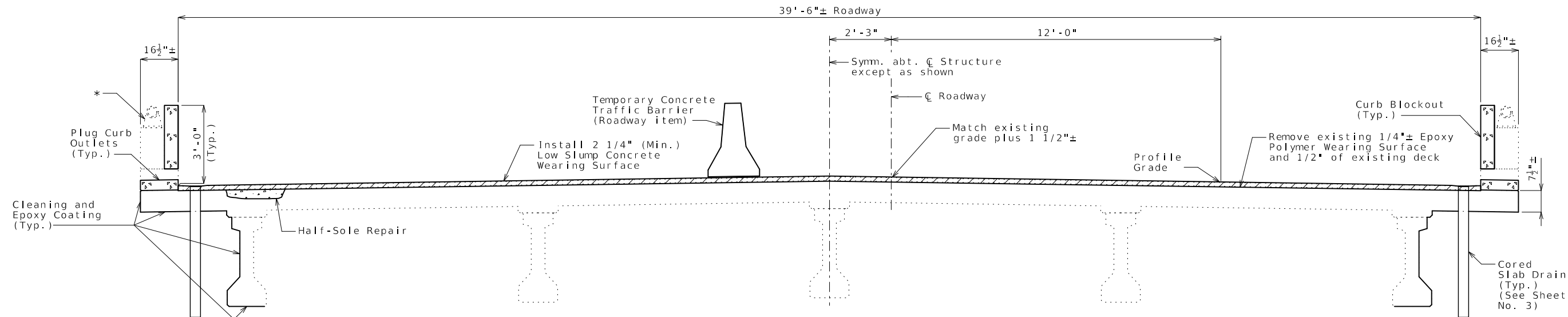

TYPICAL SECTION THRU EXISTING DECK

General Notes:

Design Specifications:

2002 AASHTO LFD (17th Ed.) Standard Specifications
Bridge Deck Rating = 5

Design Loading:

HS20-44 (Existing & New Construction)

Design Unit Stresses:

Class B-2 Concrete (Half-Sole Repair) $f'c = 4,000$ psi

Class B-1 Concrete (Curb Blockouts) $f'c = 4,000$ psi

Reinforcing Steel (Grade 60) $f_y = 60,000$ psi

Reinforcing Steel:

Minimum clearance to reinforcing steel shall be 1 1/2", unless otherwise shown.

Miscellaneous:

Roadway surfacing adjacent to bridge ends shall match new bridge approach slabs (roadway item).

All concrete repairs shall be in accordance with Sec 704, unless otherwise noted.

Outline of existing work is indicated by light dashed lines. Heavy lines indicate new work.

Contractor shall verify all dimensions in field before ordering new material.

In order to maintain grade and a minimum thickness of wearing surface as shown on plans it may be necessary to use additional quantities of wearing surface at various locations throughout the structure. The cost of furnishing and installing the wearing surface will be considered completely covered in the contract unit price, including all additional labor, materials or equipment for variations in thickness of wearing surface.

All exposed surfaces of the existing structural steel piles shall be recoated with one 6-mil thickness of aluminum epoxy-mastic primer applied over an SSPC-SP3 surface preparation in accordance with Sec 1081. The bituminous coating shall be applied one foot above and below the existing ground line and in accordance with Sec 702. These protective coatings will not be required below the normal low water line. The cost of surface preparation will be considered completely covered by the contract lump sum price for Surface Preparation for Applying Epoxy-Mastic Primer. The cost of the aluminum epoxy-mastic primer and bituminous coating will be considered completely covered by the contract lump sum price for Aluminum Epoxy-Mastic Primer.

Bars bonded in existing concrete not removed shall be cleanly stripped and embedded into new concrete where possible. If length is available, existing bars shall extend into new concrete at least 40 diameters for plain bars and 30 diameters for deformed bars, unless otherwise noted.

Traffic Handling:

Traffic to be maintained on structure during construction. See roadway plans for traffic control.

* Asbestos (Friability Category 11 NF) has been detected in the Insulaton compound between the top of the concrete parapet and the base of the handrail posts. Removal of the handrail and posts, or leave in place is the Contractor's option. Should the Contractor elect to remove the handrail and posts, the Contractor will be required to use an Abatement Contractor during the removal. No direct payment will be made for removal of the handrail and posts and for asbestos abatement should the Contractor choose to perform this work. Cost for the described work will be considered completely covered by the contract unit price for other items in the contract.

Estimated Quantities		
Item		Total
Class 1 Excavation	cu. yard	70
Temporary Shoring	lump sum	1
Removal of Seal Coat or Polymer Wearing Surface	sq. foot	5693
Removal of Existing Bridge Approach Slab	sq. foot	1856
Bridge Approach Slab (Major)	sq. yard	178
Low Slump Concrete Wearing Surface	sq. yard	633
Curb Blockout	linear foot	320
Half-Sole Repair	sq. foot	100
Cleaning and Epoxy Coating	sq. foot	2200
Plugging Existing Curb Outlets	each	38
Surface Preparation for Applying Epoxy-Mastic Primer	lump sum	1
Aluminum Epoxy-Mastic Primer	lump sum	1
Cored Slab Drains	each	22
Vertical Drain At End Bents	each	2

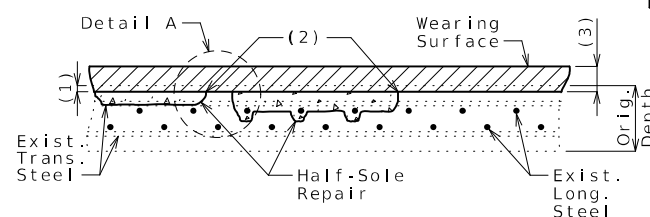

HALF-SOLE REPAIR

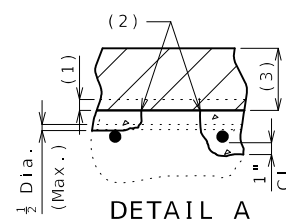

- (1) Removal of existing 1/4"± Epoxy Polymer Wearing Surface plus 1/2" of existing deck.
- (2) 1" vertical side shall be established outside the deteriorated area.
- (3) 2 1/4" minimum low slump concrete wearing surface.

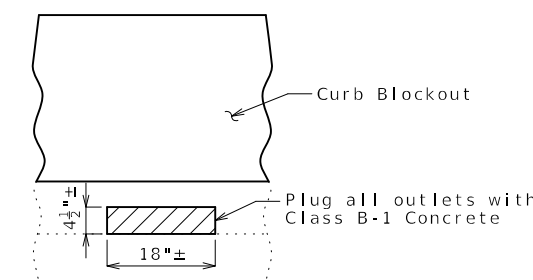

PART ELEVATION SHOWING PLUGGING OF CURB OUTLETS

Notes:

New 2 1/4" Low Slump Concrete Wearing Surface not shown for clarity.

Cost of labor and materials required to plug existing curb outlets will be considered completely covered by the contract unit price for Plugging Existing Curb Outlets.

Estimated material required to fill all curb outlets is 1.1 cubic yards (for information only).

REPAIRS TO BRIDGE: ROUTE 1-29 NB OVER MILL CREEK

ROUTE 1-29 FROM ROUTE W TO ROUTE 111 ABOUT 3.0 MILES NORTH OF ROUTE W BEGINNING STATION 1157+99.60 ± (MATCH EXISTING)

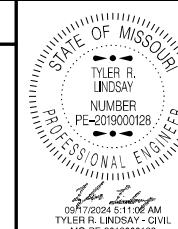

DATE PREPARED

9/16/2024

ROUTE STATE

I-29 MO

DISTRICT SHEET NO.

BR 1

COUNTY

ATCHISON

JOB NO.

J113280

CONTRACT ID.

PROJECT NO.

BRIDGE NO.

A27143

DESCRIPTION

DATE

MISSOURI HIGHWAYS AND TRANSPORTATION COMMISSION

105 WEST CAPITOL JEFFERSON CITY, MO 65102 1-888-ASK-MODOT (1-888-275-6636)



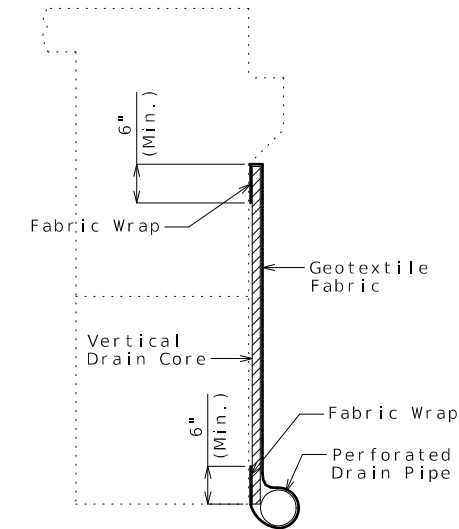
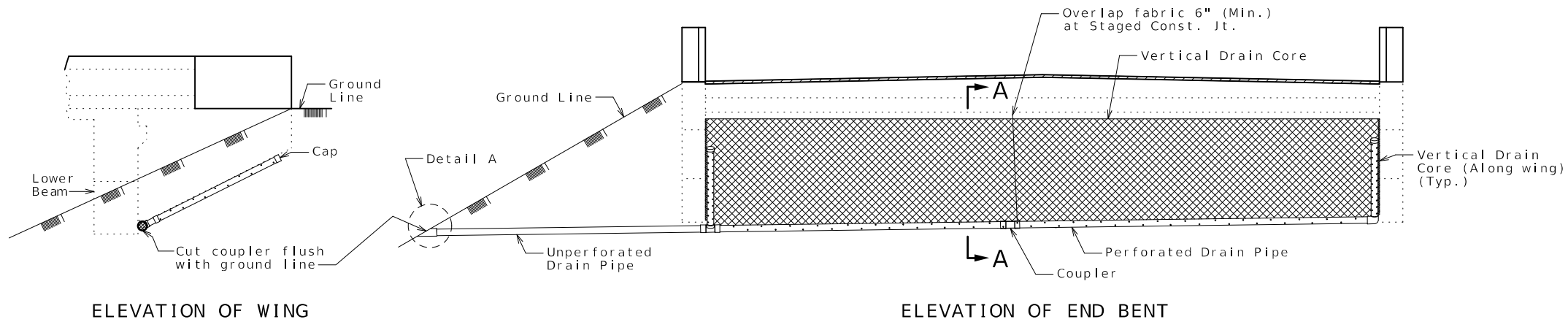

ELEVATION OF WING

ELEVATION OF END BENT

PART SECTION A-A
(Section thru wing similar)

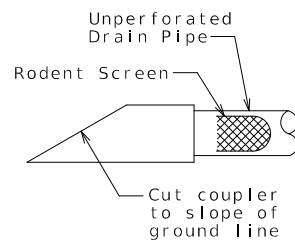

DETAIL A

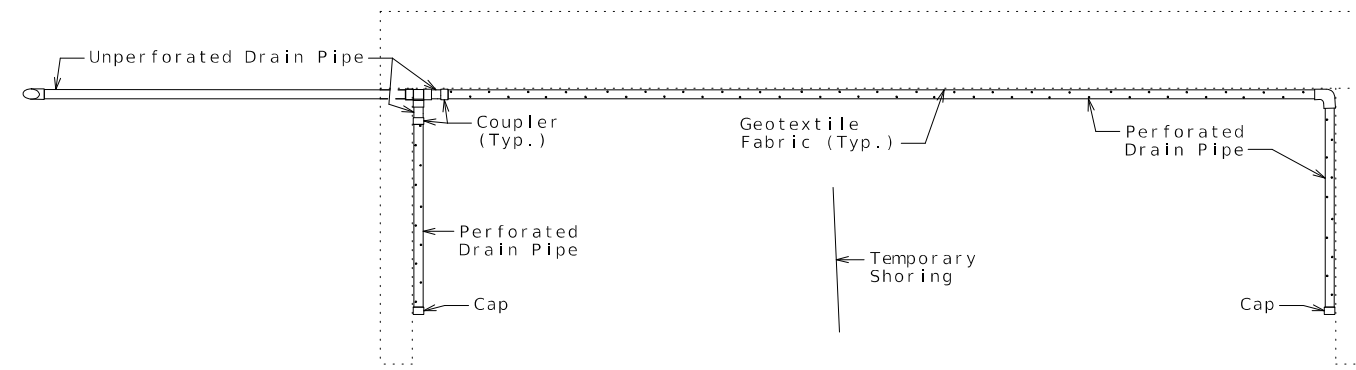

PLAN OF END BENT

VERTICAL DRAIN AT END BENTS
(Squared end bent shown, skewed end bent similar)

General Notes:

- All drain pipe shall be sloped 1 to 2 percent.
- Drain pipe may be either 6-inch diameter corrugated metallic-coated steel pipe underdrain, 4-inch diameter corrugated polyvinyl chloride (PVC) drain pipe, or 4-inch diameter corrugated polyethylene (PE) drain pipe.
- Drain pipe shall be placed at fill face of end bent and inside face of wings. The pipe shall slope to lowest grade of ground line, also missing the lower beam of end bent by a minimum of 1 1/2 inches.
- Perforated pipe shall be placed at fill face side and inside face of wings at the bottom of end bent and plain pipe shall be used where the vertical drain ends to the exit at ground line.

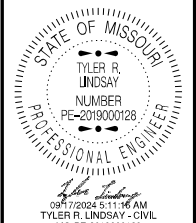

DATE PREPARED 9/16/2024	
ROUTE I-29	STATE MO
DISTRICT BR	SHEET NO. 2
COUNTY ATCHISON	
JOB NO. J113280	
CONTRACT ID.	
PROJECT NO.	
BRIDGE NO. A27143	

DATE	DESCRIPTION

MISSOURI HIGHWAYS AND TRANSPORTATION COMMISSION

105 WEST CAPITOL
JEFFERSON CITY, MO 65102
1-888-ASK-MODOT (1-888-275-6636)

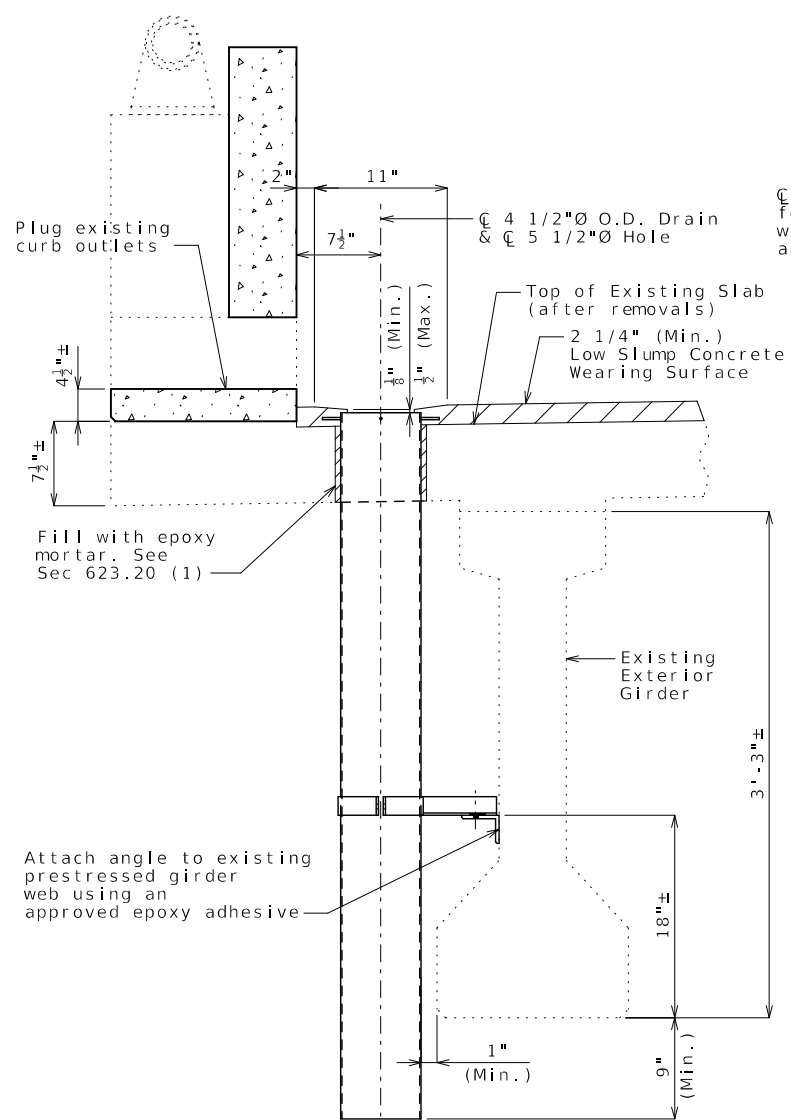

(1) Use backer rod around drain @ bottom of slab and epoxy inject from the top.

PART SECTION NEAR DRAIN

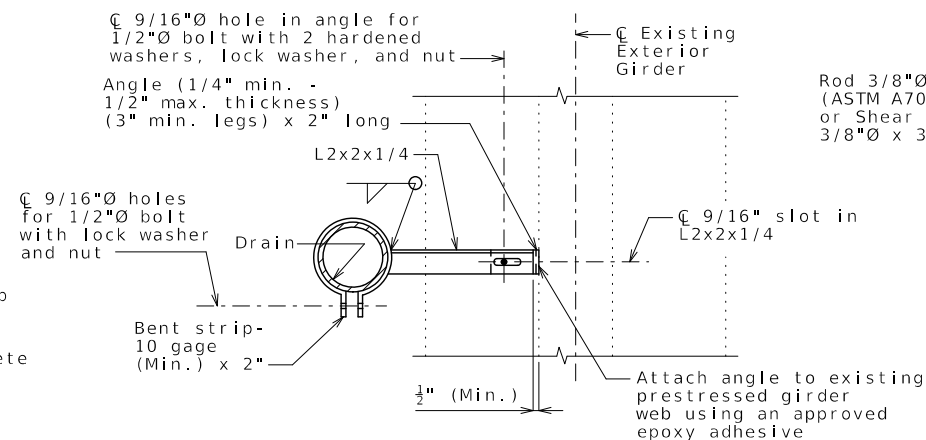

PART SECTION SHOWING BRACKET ASSEMBLY

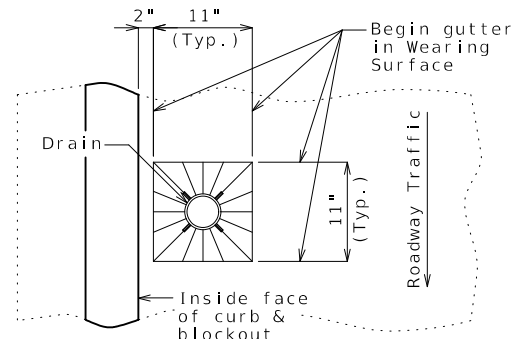

PART PLAN OF SLAB AT DRAIN

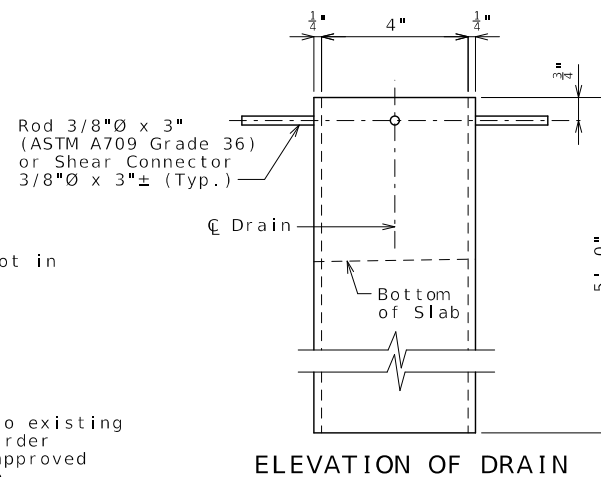

ELEVATION OF DRAIN

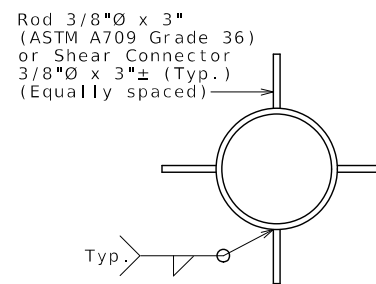

PLAN OF DRAIN

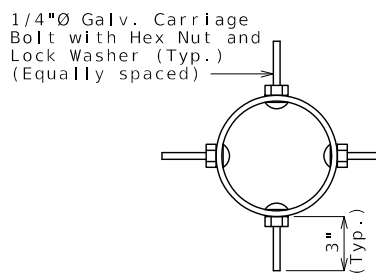

PLAN OF OPTIONAL FRP DRAIN

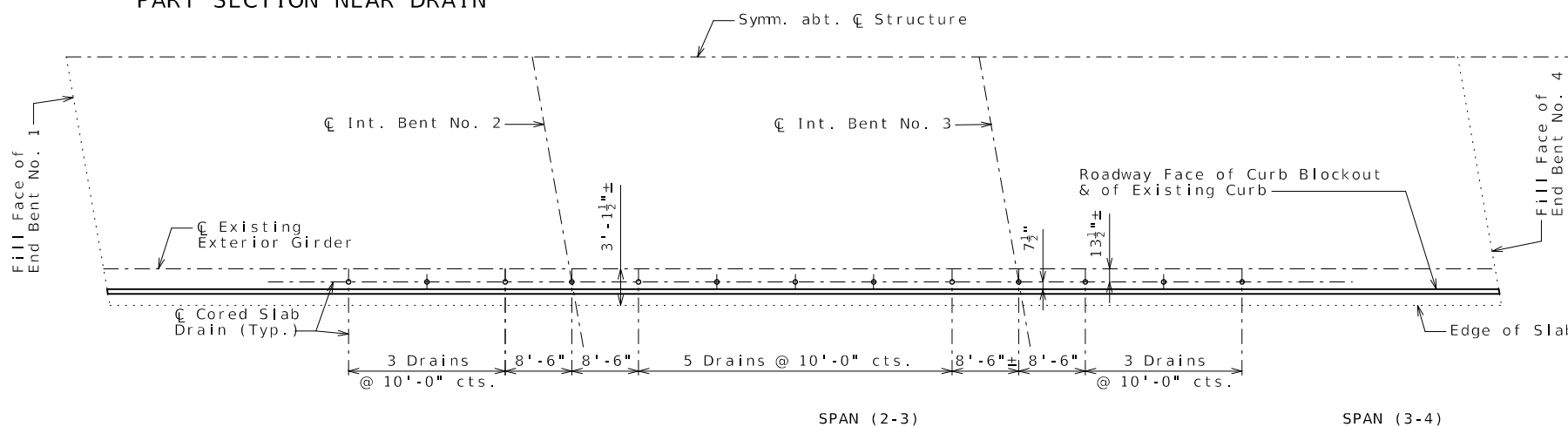

PART PLAN SHOWING CORED SLAB DRAIN LOCATIONS

CORED SLAB DRAINS

General Notes:

Contractor shall have the option to construct either steel or FRP slab drains. All drains shall be of same type.

Slab drain bracket assembly shall be ASTM A709 Grade 36 steel.

The bracket assembly shall be galvanized in accordance with ASTM A123.

All bolts, hardened washers, lock washers and nuts shall be galvanized in accordance with AASHTO M232 (ASTM A153), Class C.

All 1/2-inch diameter bolts shall be ASTM A307, except as noted.

Shop drawings will not be required for the slab drains and the bracket assembly.

Cost of cored slab drains, complete in place, will be considered completely covered by the contract unit price for Cored Slab Drain per each.

Holes for slab drains shall be cored. Percussion drilling will not be permitted.

Slab drain locations may be shifted the minimum extent necessary to avoid slab reinforcement.

Cored slab drains shall be placed vertically.

For details of plugging existing curb outlets, see Sheet No. 1.

Notes for Steel Drain:

Slab drains shall be fabricated from 1/4-inch structural steel tubing ASTM A500 or A501.

The drains shall be galvanized in accordance with ASTM A123.

Drains shall be inserted through slab such that damage to galvanized coating is minimized.

Notes for FRP Drain:

Drains shall be machine filament-wound thermosetting resin tubing meeting the requirements of ASTM D2996 with the following exceptions:

Minimum reinforced wall thickness shall be 1/4 inch.

The resin used shall be ultraviolet (UV) resistant and/or have UV inhibitors mixed throughout. Drains may have an exterior coating for additional UV resistance. Care shall be taken to avoid damage to exterior coating during installation.

The color of the slab drain shall be gray (Federal Standard 26373). The color shall be uniform throughout the resin and any coating used.

The combination of materials used in the manufacture of the drains shall be tested for UV resistance in accordance with ASTM D4329 Cycle A. The representative material shall withstand at least 500 hours of testing with only minor discoloration and without any physical deterioration. The contractor shall furnish the results of the required ultraviolet testing prior to acceptance of the slab drains.

At the contractor's option, drains may be field cut. The method of cutting FRP slab drains shall be as recommended by the manufacturer to ensure a smooth, chip-free cut.

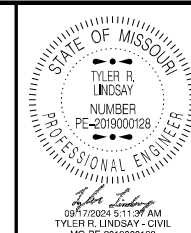

DATE PREPARED
9/16/2024

ROUTE
I-29

STATE
MO

DISTRICT
BR

SHEET NO.
3

COUNTY
ATCHISON

JOB NO.
J113280

CONTRACT ID.

PROJECT NO.

BRIDGE NO.
A27143

DESCRIPTION

DATE

MISSOURI HIGHWAYS AND TRANSPORTATION COMMISSION

105 WEST CAPITOL JEFFERSON CITY, MO 65102

1-888-ASK-MODOT (1-888-275-6636)



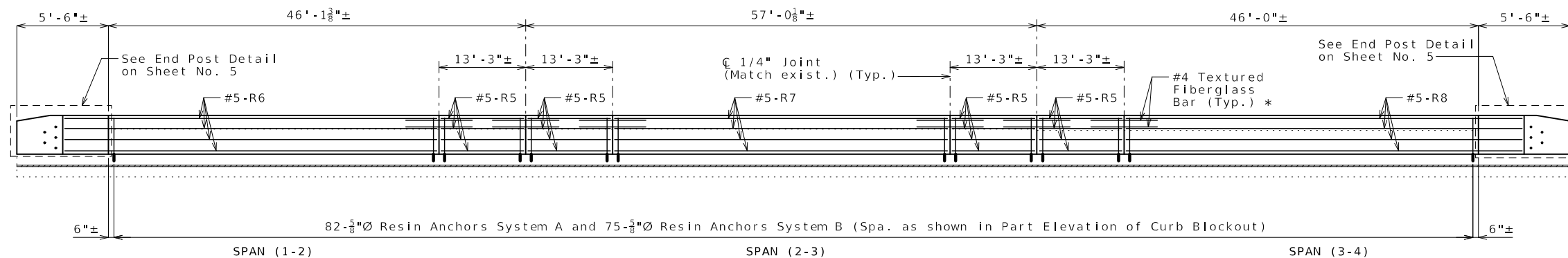

ELEVATION OF LEFT CURB BLOCKOUT
(Right curb blockout similar)

Longitudinal dimensions are along grade and are taken at top outside edge of parapet.

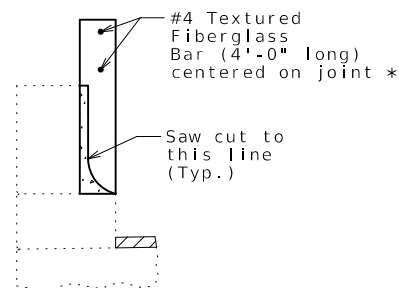

SECTION THRU SAW CUT JOINT

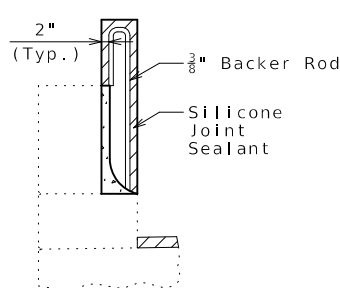

DETAILS OF RESIN ANCHORS

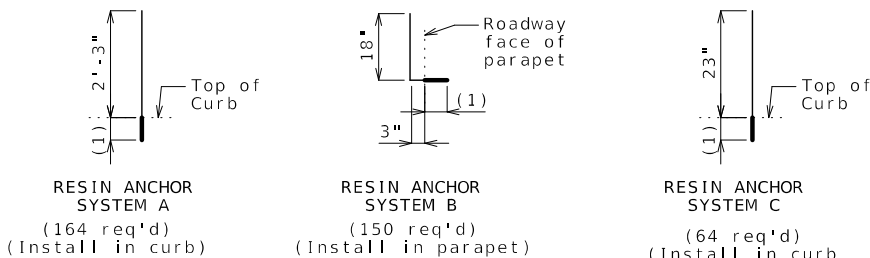

(1) Use manufacturer's embedment length (5" minimum embedment).

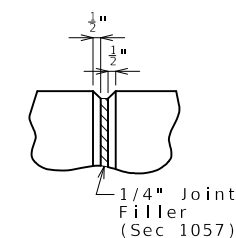

PART ELEVATION AT FORMED JOINT

Notes:

* Slip-formed option only.

Conventional forming or slip forming may be used. Saw cut joints may be used with conventional forming.

Bridge rail not shown for clarity.

Concrete in curb blockout shall be Class B-1.

Measurement of curb blockout is to the nearest linear foot, measured at the top outside edge of parapet. (Match existing curb and parapet)

All exposed edges of curb blockout shall have either a 1/2-inch radius or 3/8-inch bevel, unless otherwise noted.

Payment for concrete, reinforcement, resin anchor systems and any other work incidental to the curb blockout, complete in place, will be considered completely covered by the contract unit price for Curb Blockout per linear foot.

Cost of any concrete curb or parapet repair will be considered completely covered by the contract unit price for Curb Blockout.

All curb blockout reinforcement shall be epoxy coated.

(2) Shift resin anchors where necessary to clear existing anchor bolts for bridge rail, miss curb outlets (if present) and clear existing reinforcement.

Use a minimum lap of 3'-1" for #5 horizontal curb blockout bars.

Concrete traffic barrier delineators shall be placed on top of the curb blockout similarly as shown on Missouri Standard Plans 617.10 and in accordance with Sec 617. Delineators on bridges with two-lane, two-way traffic shall have retroreflective sheeting on both sides. Concrete traffic barrier delineators will be considered completely covered by the contract unit price for Curb Blockout.

The contractor shall use one of the qualified resin anchor systems in accordance with Sec 1039.

The minimum embedment depth in concrete with f'c = 4,000 psi for the resin anchor system shall be that required to meet the minimum ultimate pullout strength in accordance with Sec 1039 but shall not be less than 5 inches.

An epoxy coated #5 Grade 60 reinforcing bar shall be substituted for the 5/8"Ø threaded rod.

For slip-formed option, both sides of the curb blockout shall have a vertically broomed finish and the top shall have a transversely broomed finish.

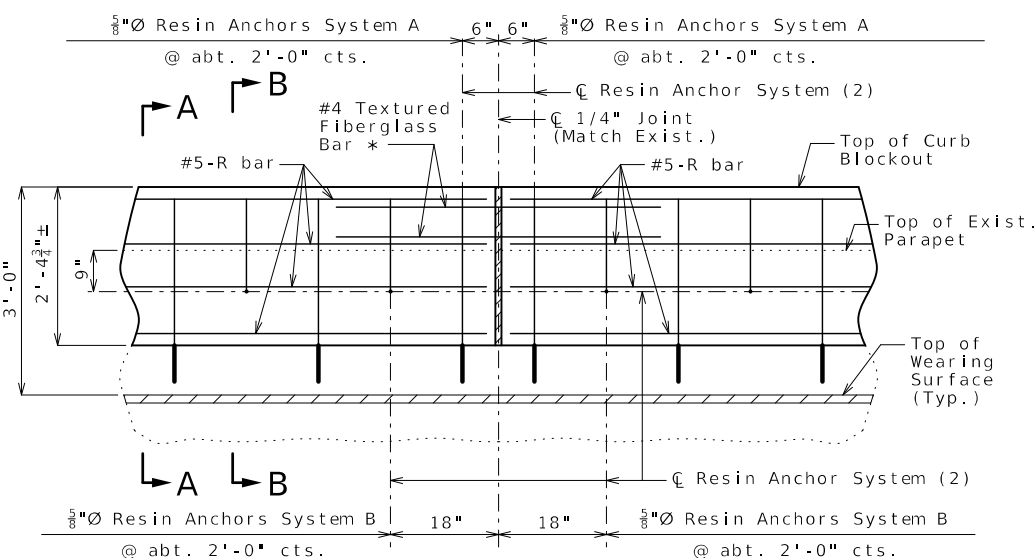

PART ELEVATION OF CURB BLOCKOUT

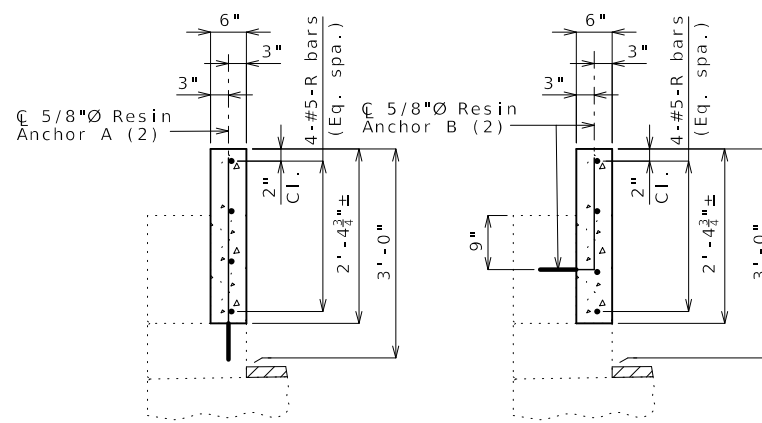

SECTION A-A

SECTION B-B

CURB BLOCKOUT

Sheet No. 4 of 8

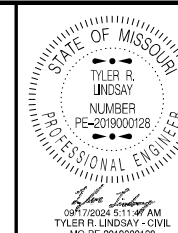

DATE PREPARED
9/16/2024

ROUTE
I-29

STATE
MO

DISTRICT
BR

SHEET NO.
4

COUNTY
ATCHISON

JOB NO.
J113280

CONTRACT ID.

PROJECT NO.

BRIDGE NO.
A27143

DESCRIPTION	DATE

MISSOURI HIGHWAYS AND TRANSPORTATION COMMISSION

105 WEST CAPITOL
JEFFERSON CITY, MO 65102
1-888-ASK-MODOT (1-888-275-6636)

U.I.P. AND REHABILITATE EXISTING (43'-57'-43') PRESTRESSED CONCRETE I-GIRDER SPANS
(SKEW: 10°00'00" R.A.)

SEC/SUR 2 TWP 63N RGE 41W

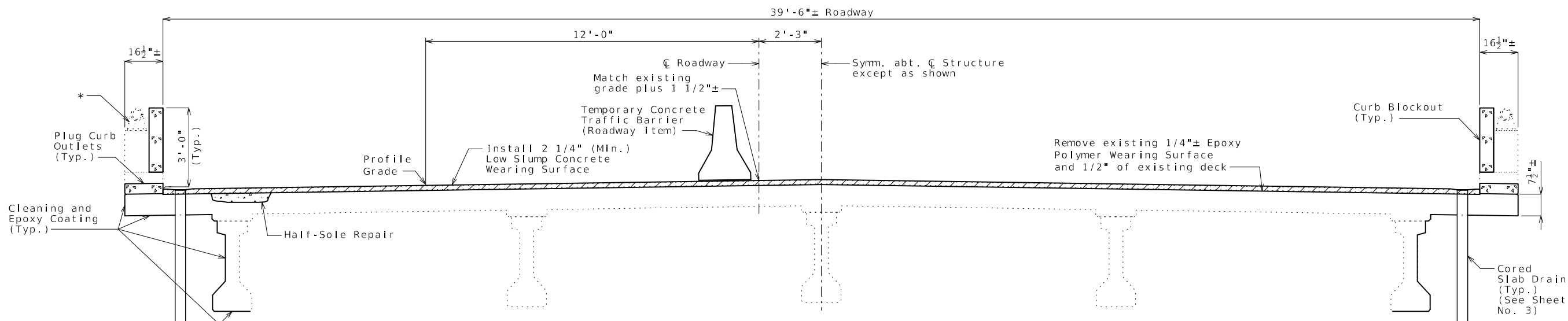

TYPICAL SECTION THRU EXISTING DECK

General Notes:

Design Specifications:

2002 AASHTO LFD (17th Ed.) Standard Specifications
Bridge Deck Rating = 5

Design Loading:

HS20-44 (Existing & New Construction)

Design Unit Stresses:

Class B-2 Concrete (Half-Sole Repair) f'c = 4,000 psi

Class B-1 Concrete (Curb Blockouts) f'c = 4,000 psi

Reinforcing Steel (Grade 60) fy = 60,000 psi

Reinforcing Steel:

Minimum clearance to reinforcing steel shall be 1 1/2", unless otherwise shown.

Miscellaneous:

Roadway surfacing adjacent to bridge ends shall match new bridge approach slabs (roadway item).

All concrete repairs shall be in accordance with Sec 704, unless otherwise noted.

Outline of existing work is indicated by light dashed lines. Heavy lines indicate new work.

Contractor shall verify all dimensions in field before ordering new material.

In order to maintain grade and a minimum thickness of wearing surface as shown on plans it may be necessary to use additional quantities of wearing surface at various locations throughout the structure. The cost of furnishing and installing the wearing surface will be considered completely covered in the contract unit price, including all additional labor, materials or equipment for variations in thickness of wearing surface.

All exposed surfaces of the existing structural steel piles shall be recoated with one 6-mil thickness of aluminum epoxy-mastic primer applied over an SSPC-SP3 surface preparation in accordance with Sec 1081. The bituminous coating shall be applied one foot above and below the existing ground line and in accordance with Sec 702. These protective coatings will not be required below the normal low water line. The cost of surface preparation will be considered completely covered by the contract lump sum price for Surface Preparation for Applying Epoxy-Mastic Primer. The cost of the aluminum epoxy-mastic primer and bituminous coating will be considered completely covered by the contract lump sum price for Aluminum Epoxy-Mastic Primer.

Bars bonded in existing concrete not removed shall be cleanly stripped and embedded into new concrete where possible. If length is available, existing bars shall extend into new concrete at least 40 diameters for plain bars and 30 diameters for deformed bars, unless otherwise noted.

Traffic Handling:

Traffic to be maintained on structure during construction. See roadway plans for traffic control.

* Asbestos (Friability Category 11 NF) has been detected in the Insulaton compound between the top of the concrete parapet and the base of the handrail posts. Removal of the handrail and posts, or leave in place is the Contractor's option. Should the Contractor elect to remove the handrail and posts, the Contractor will be required to use an Abatement Contractor during the removal. No direct payment will be made for removal of the handrail and posts and for asbestos abatement should the Contractor choose to perform this work. Cost for the described work will be considered completely covered by the contract unit price for other items in the contract.

Estimated Quantities

Item	Unit	Total
Class 1 Excavation	cu. yard	70
Temporary Shoring	lump sum	1
Removal of Seal Coat or Polymer Wearing Surface	sq. foot	5693
Removal of Existing Bridge Approach Slab	sq. foot	1856
Bridge Approach Slab (Major)	sq. yard	178
Low Slump Concrete Wearing Surface	sq. yard	633
Curb Blockout	linear foot	320
Half-Sole Repair	sq. foot	100
Cleaning and Epoxy Coating	sq. foot	2200
Plugging Existing Curb Outlets	each	38
Surface Preparation for Applying Epoxy-Mastic Primer	lump sum	1
Aluminum Epoxy-Mastic Primer	lump sum	1
Cored Slab Drains	each	22
Vertical Drain At End Bents	each	2

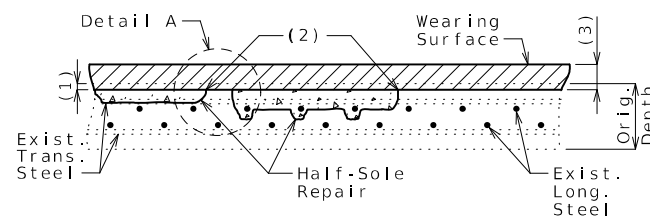

HALF-SOLE REPAIR

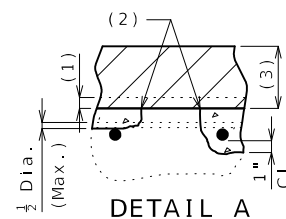

PART ELEVATION SHOWING PLUGGING OF CURB OUTLETS

Notes:

New 2 1/4" Low Slump Concrete Wearing Surface not shown for clarity.

Cost of labor and materials required to plug existing curb outlets will be considered completely covered by the contract unit price for Plugging Existing Curb Outlets.

Estimated material required to fill all curb outlets is 1.1 cubic yards (for information only).

REPAIRS TO BRIDGE: ROUTE I-29 SB OVER MILL CREEK

ROUTE I-29 FROM ROUTE W TO ROUTE E
ABOUT 3.0 MILES NORTH OF ROUTE 111
BEGINNING STATION 1158+14.40 ± (MATCH EXISTING)

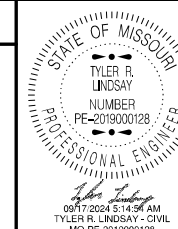

DATE PREPARED

9/16/2024

ROUTE I-29 STATE MO

DISTRICT BR SHEET NO. 1

COUNTY ATCHISON

JOB NO. J113280

CONTRACT ID.

PROJECT NO.

BRIDGE NO. A27144

DESCRIPTION

DATE

MISSOURI HIGHWAYS AND TRANSPORTATION COMMISSION

105 WEST CAPITOL
JEFFERSON CITY, MO 65102
1-888-ASK-MODOT (1-888-275-6636)



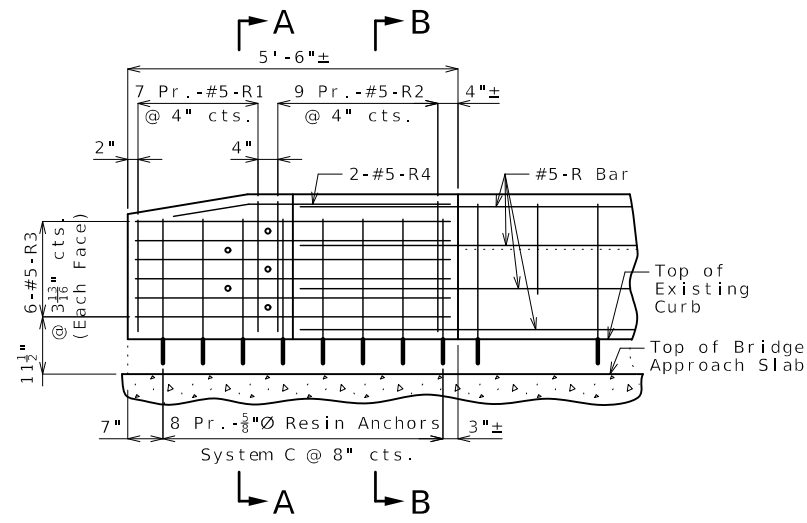

ELEVATION SHOWING REINFORCEMENT
(Right End Post at End Bent No. 4 similar)

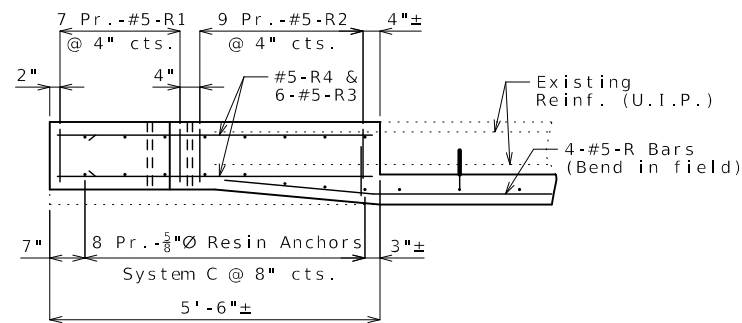

PLAN SHOWING REINFORCEMENT
LEFT END POST AT END BENT NO. 1

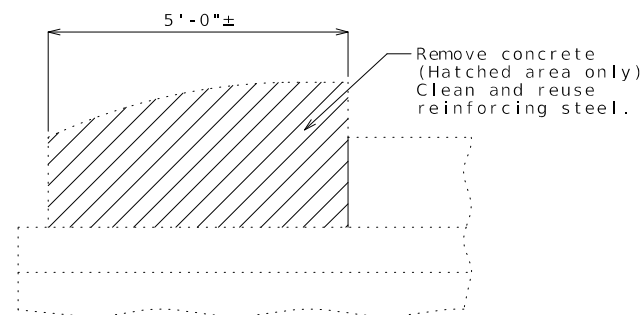

PART ELEVATION SHOWING END POST
CONCRETE REMOVAL

Cost of removing existing end posts will be considered completely covered by the contract unit price for Curb Blockout.

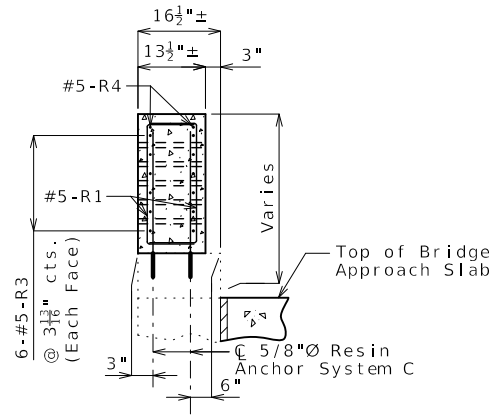

SECTION A-A

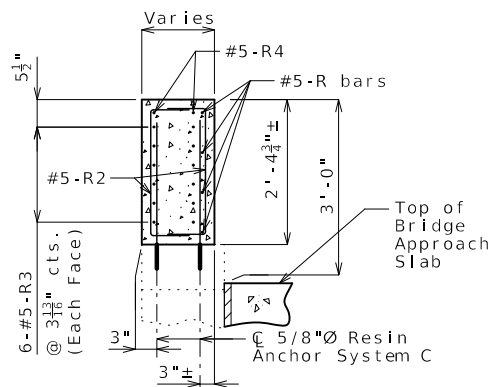

SECTION B-B

Notes:

- Work this sheet with Sheet No. 4.
- For details of resin anchors, see Sheet No. 4.
- Resin anchors shall be shifted or bent in field to clear one-inch diameter holes by at least 1/2 inch.
- For details of Bridge Approach slab, see sheet No. 6.

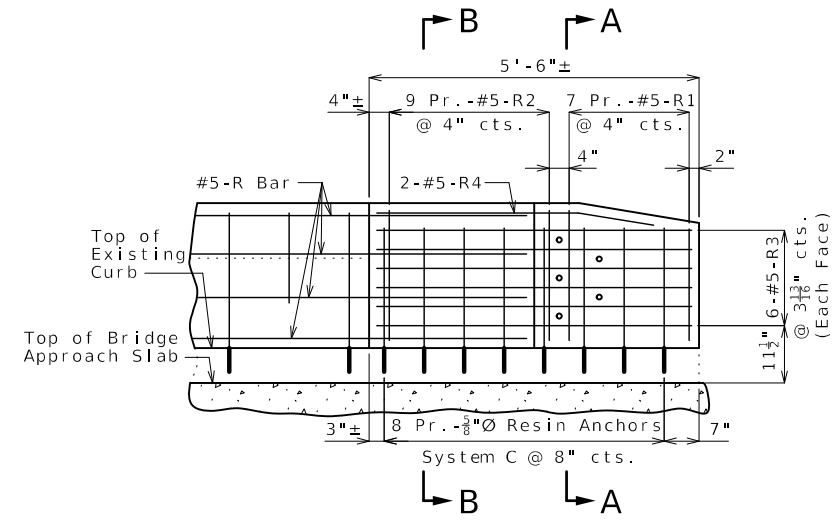

ELEVATION SHOWING REINFORCEMENT
(Right End Post at End Bent No. 1 similar)

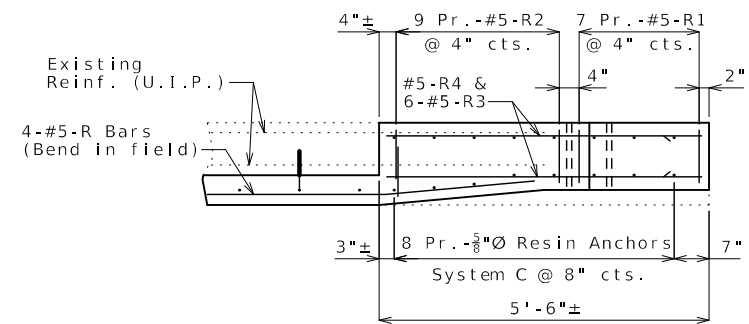

PLAN SHOWING REINFORCEMENT
LEFT END POST AT END BENT NO. 4

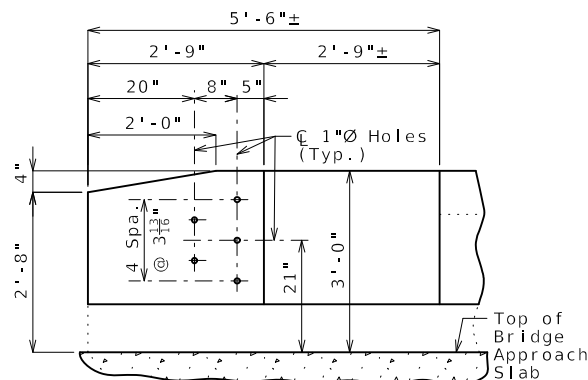
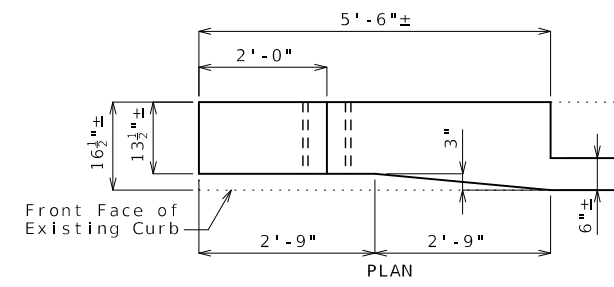

ELEVATION
DETAILS OF END POST AND
GUARD RAIL ATTACHMENT

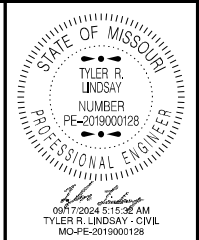

DATE PREPARED 9/16/2024	
ROUTE I-29	STATE MO
DISTRICT BR	SHEET NO. 5
COUNTY ATCHISON	
JOB NO. J113280	
CONTRACT ID.	
PROJECT NO.	
BRIDGE NO. A27144	

DATE	DESCRIPTION

MISSOURI HIGHWAYS AND TRANSPORTATION COMMISSION

105 WEST CAPITOL
JEFFERSON CITY, MO 65102
1-888-ASK-MODOT (1-888-275-6636)

CURB BLOCKOUT AT END BENTS

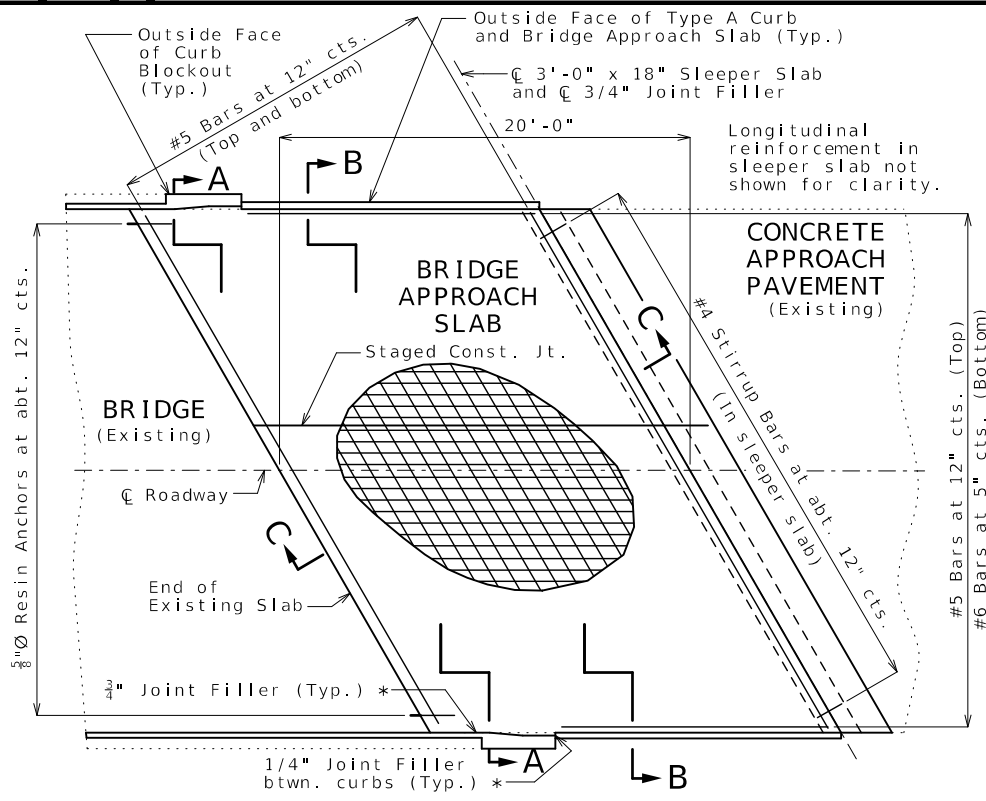

PART PLAN SHOWING REINFORCEMENT

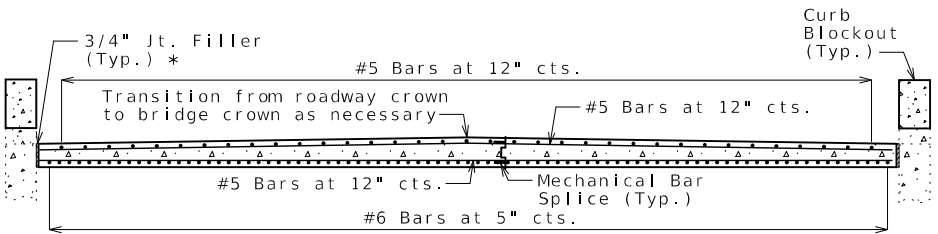

SECTION A-A

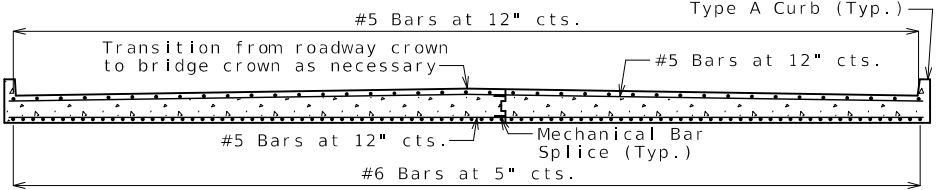

SECTION B-B

With the approval of the engineer, the contractor may crown the bottom of the approach slab to match the crown of the roadway surface.

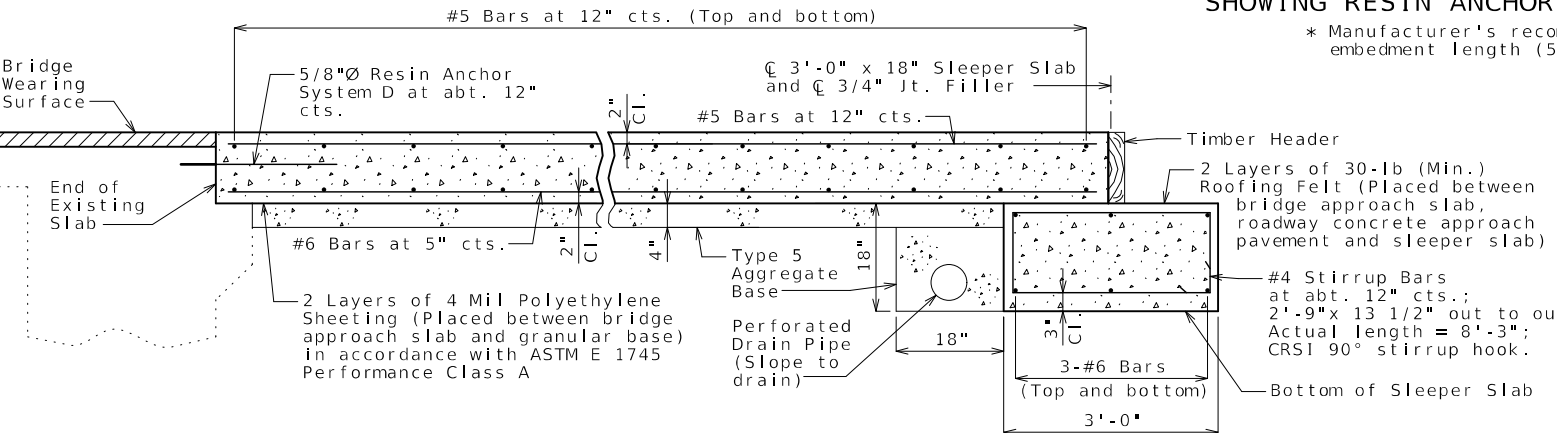

SECTION C-C

BRIDGE APPROACH SLAB (MAJOR)

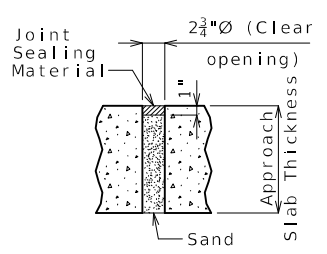

UNDERSEAL ACCESS HOLE DETAIL

(If required)

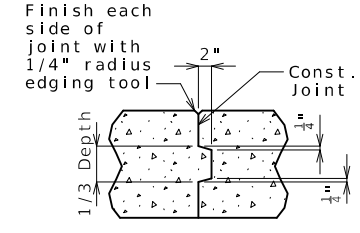

CONSTRUCTION JOINT DETAIL

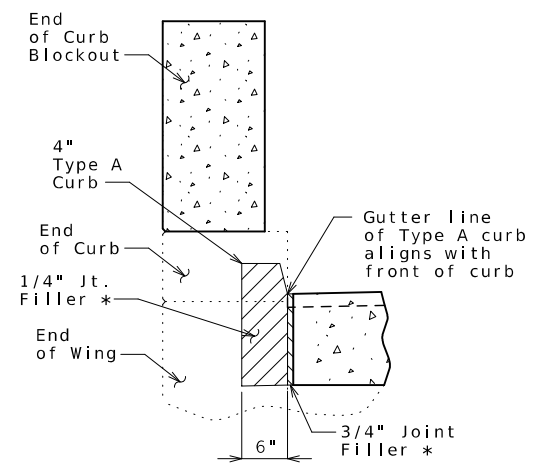

SECTION BETWEEN CURBS

5/8" Resin Anchor System E (80 Req'd) with 5/8" threaded rod with flat washer & two heavy hex nuts at 12" cts. (burr threads to prevent loosening). All hardware for Resin Anchor System E shall be galvanized in accordance with ASTM A153.

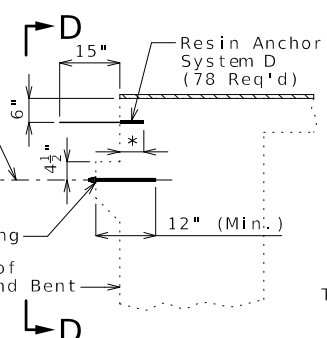

SECTION THRU END BENTS SHOWING RESIN ANCHOR SYSTEMS

* Manufacturer's recommended embedment length (5" min.)

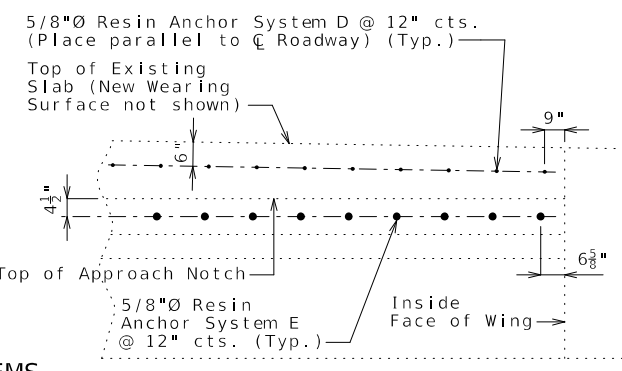

PART ELEVATION D-D

Resin Anchor System Notes:

The Contractor shall use one of the qualified resin anchor systems in accordance with Sec 1039.

Cost of furnishing and installing the resin anchor systems shown here, complete in place, will be considered completely covered by the contract unit price for Bridge Approach Slab (Major).

The minimum embedment depth in concrete with f'c = 4,000 psi for the resin anchor systems shall be that required to meet the minimum ultimate pullout strength in accordance with Sec 1039 but shall not be less than 5" for System D and as shown for System E.

An epoxy coated #5 Grade 60 reinforcing bar shall be substituted for the 5/8" threaded rod for Resin Anchor System D.

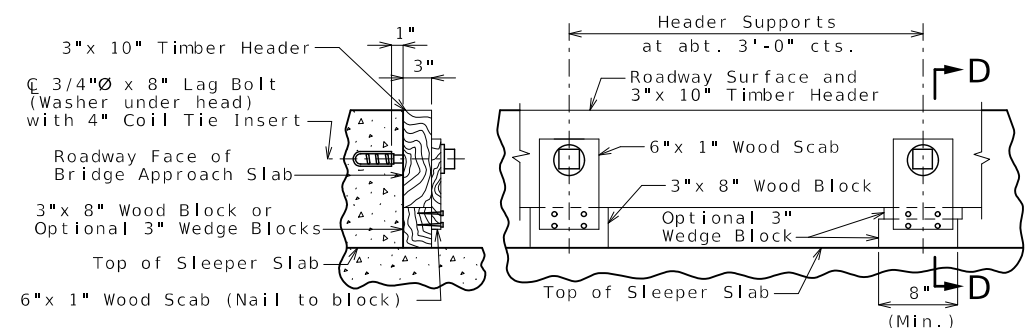

SECTION D-D

PART ELEVATION

DETAILS OF TIMBER HEADER

Remove timber header when concrete pavement is placed.

General Notes:

All concrete for the bridge approach slab and sleeper slab shall be in accordance with Sec 503 (f'c = 4,000 psi).

The reinforcing steel in the bridge approach slab and the sleeper slab shall be epoxy coated Grade 60 with fy = 60,000 psi.

Drain pipe may be either 6" diameter corrugated metallic-coated pipe underdrain, 4" diameter corrugated polyvinyl chloride (PVC) drain pipe, or 4" diameter corrugated polyethylene (PE) drain pipe.

Minimum clearance to reinforcing steel shall be 1 1/2", unless otherwise shown.

The reinforcing steel in the bridge approach slab and the sleeper slab shall be continuous. The transverse reinforcing steel may be made continuous by providing a minimum lap splice of 29 inches for #5 bars and 44 inches for #6 bars, or by mechanical bar splice.

Mechanical bar splices shall be in accordance with Sec 710. (Estimated 80 splices per slab)

All joint filler shall be in accordance with Sec 1057 for preformed fiber expansion joint filler except as noted.

The contractor shall pour and satisfactorily finish the bridge wearing surface before placing the bridge approach slab.

Longitudinal construction joints in approach slab and sleeper slab shall be aligned with longitudinal construction joints in bridge slab.

For concrete approach pavement details, see roadway plans.

See Missouri Standard Plan 609.00 for details of Type A curb.

Payment for furnishing all materials, labor and excavation necessary to construct the approach slab, including the timber header, sleeper slab, underdrain, Type 5 aggregate base, joint filler and all other appurtenances and incidental work as shown on this sheet, complete in place, will be considered completely covered by the contract unit price for Bridge Approach Slab (Major) per square yard.

* Seal joint between vertical face of approach slab and wing with sealant in accordance with Sec 717 for silicone joint sealant for saw cut and formed joints.

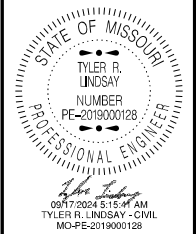

DATE PREPARED
9/16/2024

ROUTE 1-29 STATE MO
DISTRICT BR SHEET NO. 6

COUNTY ATCHISON
JOB NO. J113280
CONTRACT ID.

PROJECT NO.
BRIDGE NO. A27144

DATE	DESCRIPTION

MISSOURI HIGHWAYS AND TRANSPORTATION COMMISSION
105 WEST CAPITOL JEFFERSON CITY, MO 65102
1-888-ASK-MODOT (1-888-275-6636)

