

DESIGN DESIGNATION

I-70 WEST OF ROUTE B
 (CONSTR) A.A.D.T. - 2025 = 42,062
 (DESIGN) A.A.D.T. - 2045 = 56,510
 D.H.V. = 7.42%
 T = 42.35%
 V = 70 M.P.H.
 D (E/W) = 49.3%/50.7%

I-70 EAST OF ROUTE B
 (CONSTR) A.A.D.T. - 2025 = 51,794
 (DESIGN) A.A.D.T. - 2045 = 64,506
 D.H.V. = 7.91%
 T = 37.03%
 V = 70 M.P.H.
 D (E/W) = 51.1%/48.9%

FUNCTIONAL CLASSIFICATION-INTERSTATE

**MISSOURI HIGHWAYS AND TRANSPORTATION COMMISSION
 PLANS FOR PROPOSED
 STATE HIGHWAY
 MONTGOMERY / WARREN COUNTIES
 INTERSTATE 70**

NORTHEAST DISTRICT

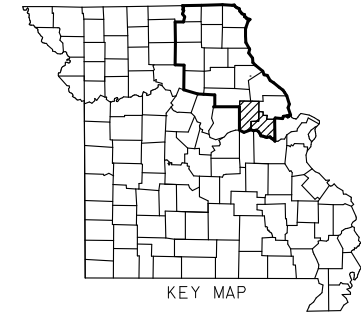
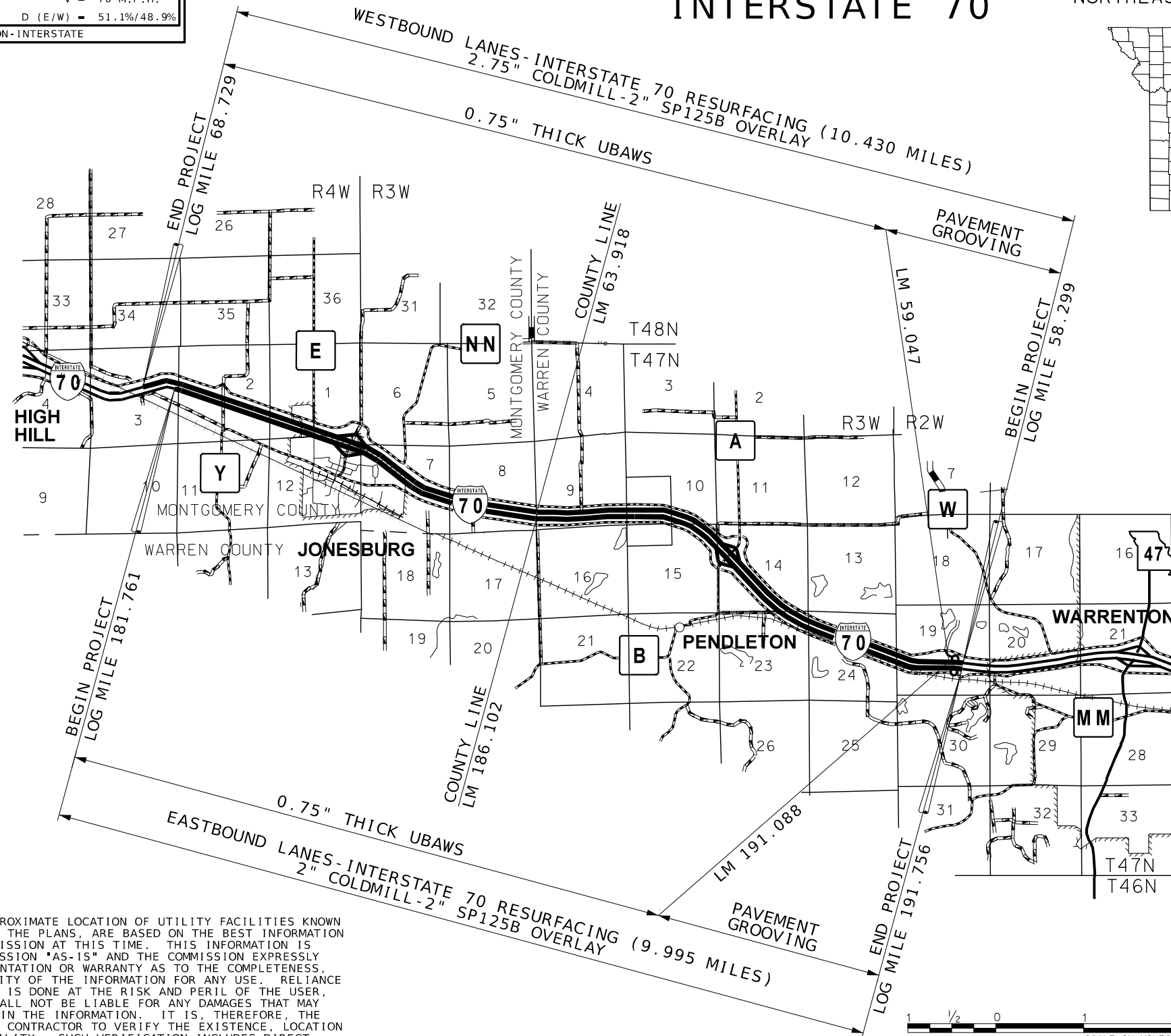

INDEX OF SHEETS

DESCRIPTION	SHEET NUMBER
TITLE SHEET	1
TYPICAL SECTIONS (TS) (3 SHEETS)	2
QUANTITIES (QU) (3 SHEETS)	3
SPECIAL SHEETS (SS)	4-8
TRAFFIC CONTROL SHEETS (TC)	9-15

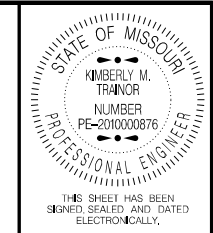

DATE PREPARED	11/12/2024
ROUTE	I-70
STATE	MO
DISTRICT	NE
SHEET NO.	1
COUNTY	MONTGOMERY / WARREN
JOB NO.	J213309
CONTRACT ID.	
PROJECT NO.	
BRIDGE NO.	

DESCRIPTION	DATE

LENGTH OF PROJECT

EASTBOUND I-70			
BEGINNING OF PROJECT	LOG MILE	181.761	
END OF PROJECT	LOG MILE	191.756	
EASTBOUND APPARENT LENGTH		9.995 MILES	
WESTBOUND I-70			
BEGINNING OF PROJECT	LOG MILE	58.299	
END OF PROJECT	LOG MILE	68.729	
WESTBOUND APPARENT LENGTH		10.430 MILES	
TOTAL APPARENT LENGTH		20.425 MILES	
EQUATIONS AND EXCEPTIONS:		0.000 MILES	
TOTAL CORRECTIONS		0.000 MILES	
STATE LENGTH		20.425 MILES	
FOR INFORMATION ONLY ESTIMATED DISTURBED ACRES		0.0 ACRES	

THE EXISTENCE AND APPROXIMATE LOCATION OF UTILITY FACILITIES KNOWN TO EXIST, AS SHOWN ON THE PLANS, ARE BASED ON THE BEST INFORMATION AVAILABLE TO THE COMMISSION AT THIS TIME. THIS INFORMATION IS PROVIDED BY THE COMMISSION "AS-IS" AND THE COMMISSION EXPRESSLY DISCLAIMS ANY REPRESENTATION OR WARRANTY AS TO THE COMPLETENESS, ACCURACY, OR SUITABILITY OF THE INFORMATION FOR ANY USE. RELIANCE UPON THIS INFORMATION IS DONE AT THE RISK AND PERIL OF THE USER, AND THE COMMISSION SHALL NOT BE LIABLE FOR ANY DAMAGES THAT MAY ARISE FROM ANY ERROR IN THE INFORMATION. IT IS, THEREFORE, THE RESPONSIBILITY OF THE CONTRACTOR TO VERIFY THE EXISTENCE, LOCATION AND STATUS OF ANY FACILITY. SUCH VERIFICATION INCLUDES DIRECT CONTACT WITH THE LISTED UTILITIES.



TITLE SHEET

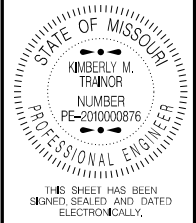

NOTES:
CROSS SLOPE:
MATCH EXISTING CROSS SLOPE

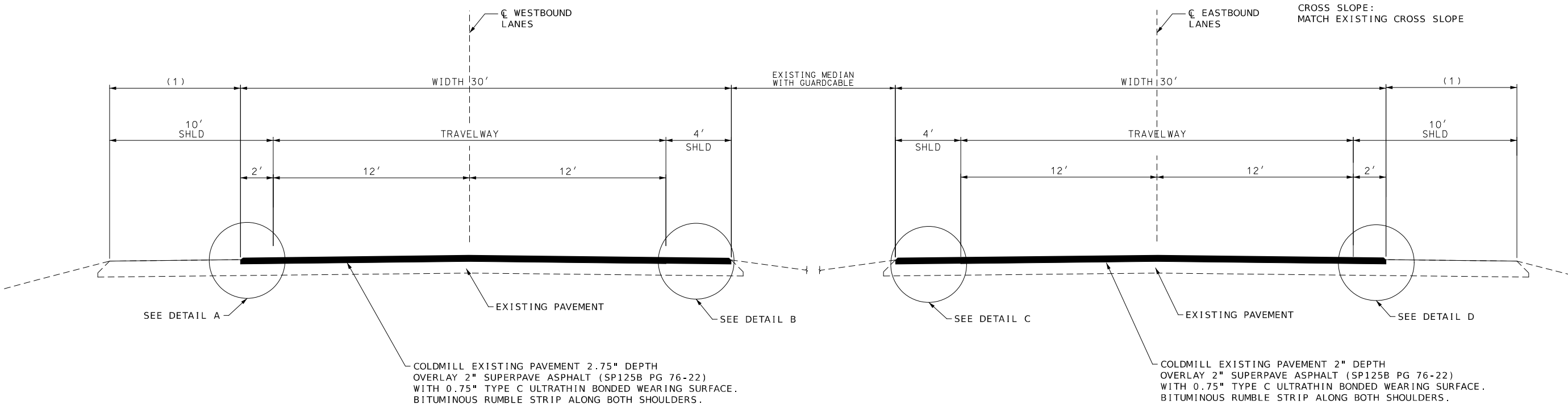

**I-70 WESTBOUND LANES
TYPICAL SECTION**

4' INSIDE SHOULDER, 24' TRAVELWAY, AND 2' OF OUTSIDE SHOULDER
LOG MILE 59.047 TO LOG MILE 68.729(WBL-END PROJECT)

**I-70 EASTBOUND LANES
TYPICAL SECTION**

4' INSIDE SHOULDER, 24' TRAVELWAY, AND 2' OF OUTSIDE SHOULDER
LOG MILE 181.761(EBL-BEGIN PROJECT) TO LOG MILE 191.088

(1)
BITUMINOUS FOG SEAL ON REMAINING ASPHALT OUTSIDE SHOULDER WIDTH. SEE INTERCHANGE RAMP TYPICAL SECTIONS FOR DECEL AND ACCEL. LANES AND RAMP.

NOTE:
ANY ADDITIONAL COLDMILLING TO REMOVE THE REMAINING PAVEMENT BEYOND 30' IS CONSIDERED INCIDENTAL TO THE COLDMILLING OPERATION.

SHOULDERS SHALL BE COLDMILLED IN CONJUNCTION WITH THE ADJACENT TRAVELWAY AND THE SP125B LIFT SHALL BE CONSTRUCTED WITHIN THE SAME DAYS OPERATION.

SEE STANDARD PLAN 401.00C FOR SAFETY EDGE DETAILS .

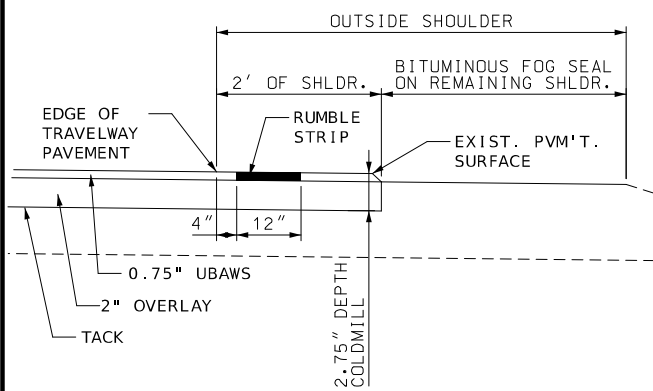

**WB-OUTSIDE SHOULDER
DETAIL A**

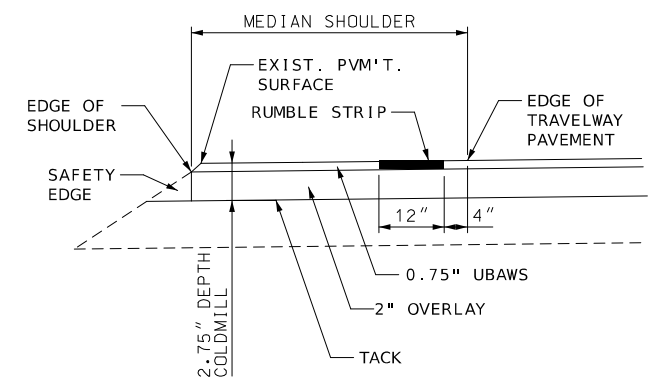

**WB-MEDIAN SHOULDER
DETAIL B**

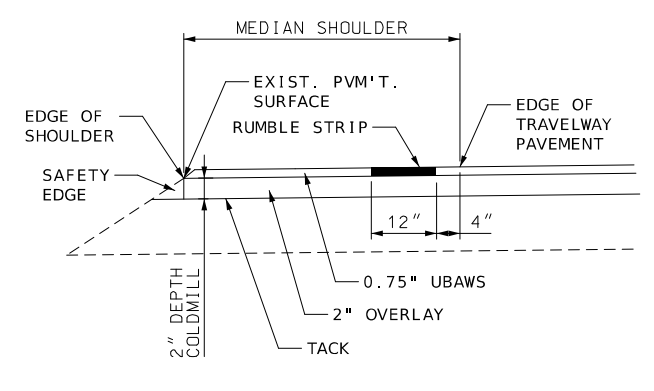

**EB-MEDIAN SHOULDER
DETAIL C**

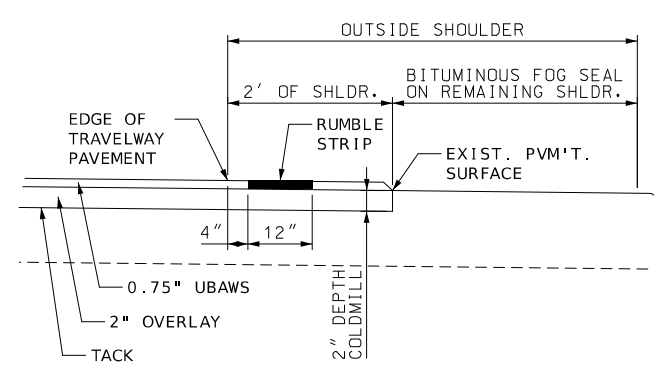

**EB-OUTSIDE SHOULDER
DETAIL D**

DATE PREPARED
11/12/2024

ROUTE **I-70** STATE **MO**
DISTRICT **NE** SHEET NO. **2**

COUNTY
WARREN/MONTGOMERY
JOB NO.
J213309
CONTRACT ID.

PROJECT NO.
BRIDGE NO.

DESCRIPTION	DATE

MISSOURI HIGHWAYS AND TRANSPORTATION COMMISSION
105 WEST CAPITOL
JEFFERSON CITY, MO 65102
1-888-ASK-MODOT (1-888-275-6636)

TYPICAL SECTION
SHEET 1 OF 3

NOTES:
CROSS SLOPE:
MATCH EXISTING CROSS SLOPE

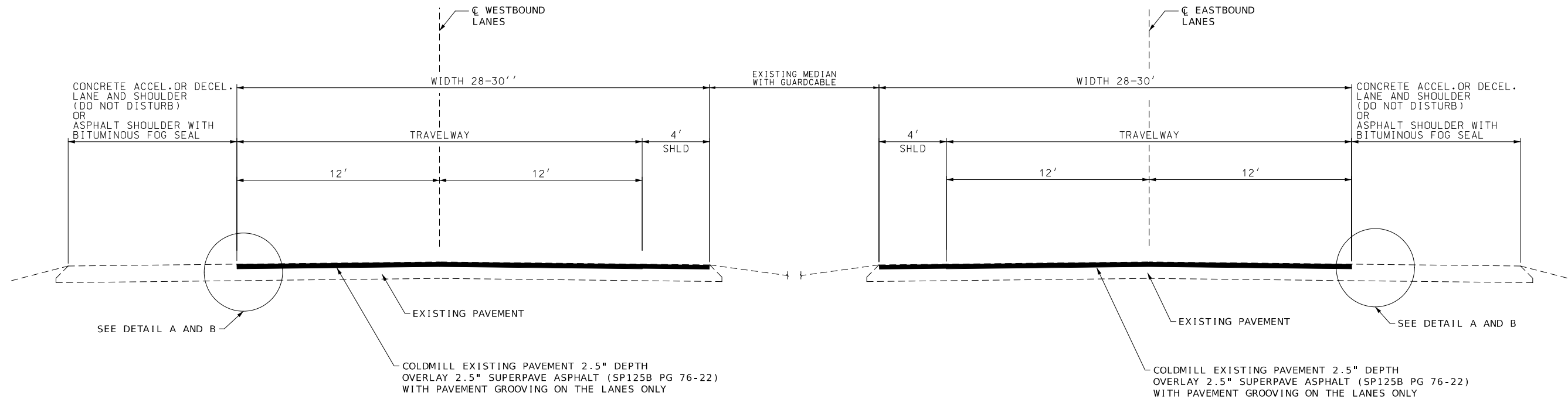

**I-70 WESTBOUND LANES
TYPICAL SECTION**

**I-70 EASTBOUND LANES
TYPICAL SECTION**

NOTE:
ANY ADDITIONAL COLDMILLING TO REMOVE THE REMAINING PAVEMENT BEYOND 28'-30' IS CONSIDERED INCIDENTAL TO THE COLDMILLING OPERATION.

SHOULDERS SHALL BE COLDMILLED IN CONJUNCTION WITH THE ADJACENT TRAVELWAY AND THE SP125B LIFT SHALL BE CONSTRUCTED WITHIN THE SAME DAYS OPERATION.

4' INSIDE SHOULDER AND 24' TRAVELWAY
ADJACENT TO CONCRETE LANES AT ROUTE MM INTERCHANGE

4' INSIDE SHOULDER AND 24' TRAVELWAY
ADJACENT TO CONCRETE LANES AT ROUTE MM INTERCHANGE

LOG MILE 58.299(WBL-BEGIN PROJECT) TO LOG MILE 58.529 (SEE DETAIL A)

LOG MILE 191.088 TO LOG MILE 191.323 (SEE DETAIL A)

LOG MILE 58.529 TO LOG MILE 58.767 (SEE DETAIL B)

LOG MILE 191.323 TO LOG MILE 191.552 (SEE DETAIL B)

LOG MILE 58.767 TO LOG MILE 59.047 (SEE DETAIL A)

LOG MILE 191.552 TO LOG MILE 191.756(EBL-END PROJECT) (SEE DETAIL A)

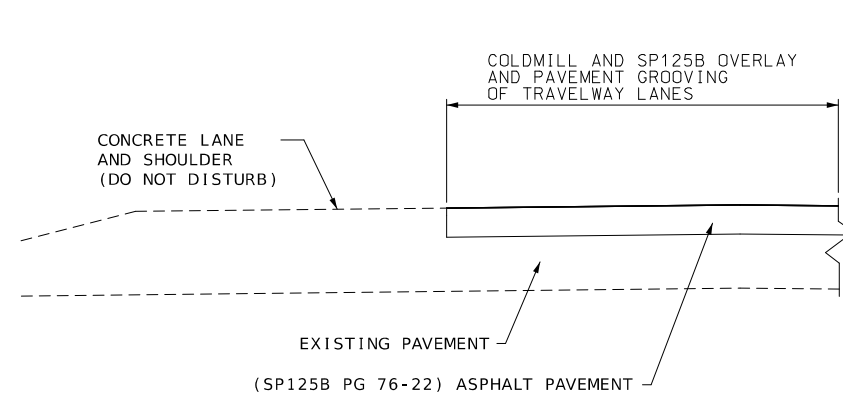

EASTBOUND OR WESTBOUND

DETAIL A

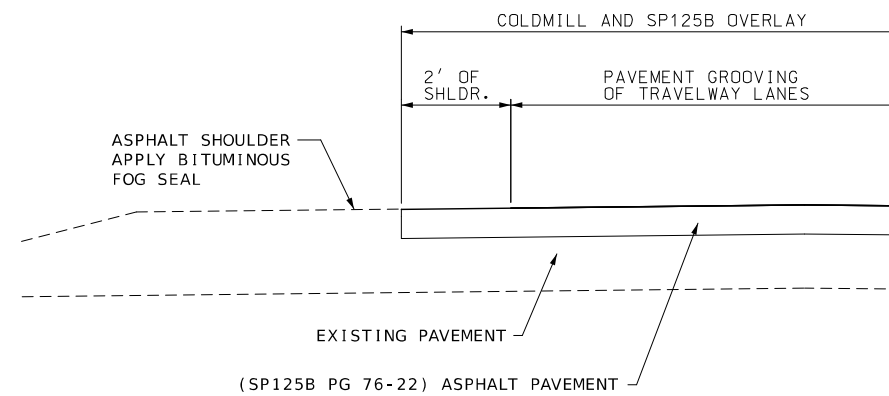

EASTBOUND OR WESTBOUND

DETAIL B

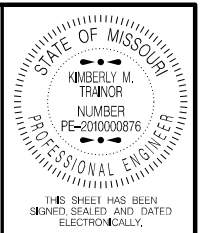

DATE PREPARED 11/12/2024	
ROUTE I-70	STATE MO
DISTRICT NE	SHEET NO. 2
COUNTY WARREN/MONTGOMERY	
JOB NO. J213309	
CONTRACT ID.	
PROJECT NO.	
BRIDGE NO.	

DESCRIPTION	DATE

MISSOURI HIGHWAYS AND TRANSPORTATION COMMISSION

105 WEST CAPITOL
JEFFERSON CITY, MO 65102
1-888-ASK-MODOT (1-888-275-6636)

TYPICAL SECTION
SHEET 2 OF 3

TYPICAL SECTIONS I-70 INTERCHANGES ROUTES Y AND A/B

NOTES:
CROSS SLOPE:
MATCH EXISTING CROSS SLOPE

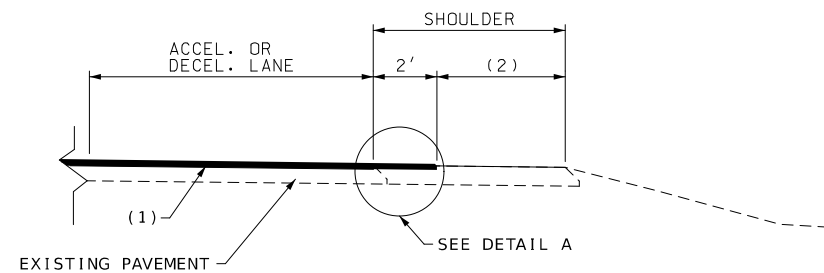

- (1)
COLDMILL EXISTING PAVEMENT (WBL-2.75") OR (EBL-2") DEPTH
OVERLAY 2" SUPERPAVE ASPHALT (SP125B PG 76-22)
WITH 0.75" TYPE C ULTRATHIN BONDED WEARING SURFACE
- (2)
BITUMINOUS FOG SEAL ON REMAINING ASPHALT
SHOULDER WIDTH.

ROUTE Y
EBL-LM 183.539 TO LM 183.620
EBL-LM 183.918 TO LM 184.099

WBL-LM 66.043 TO LM 66.102
WBL-LM 66.383 TO LM 66.543

ROUTES A/B
EBL-LM 188.195 TO LM 188.305
EBL-LM 188.605 TO LM 188.755

WBL-LM 61.312 TO LM 61.423
WBL-LM 61.703 TO LM 61.872

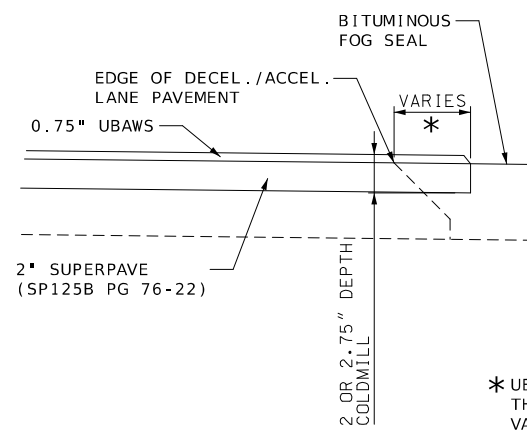

DETAIL A

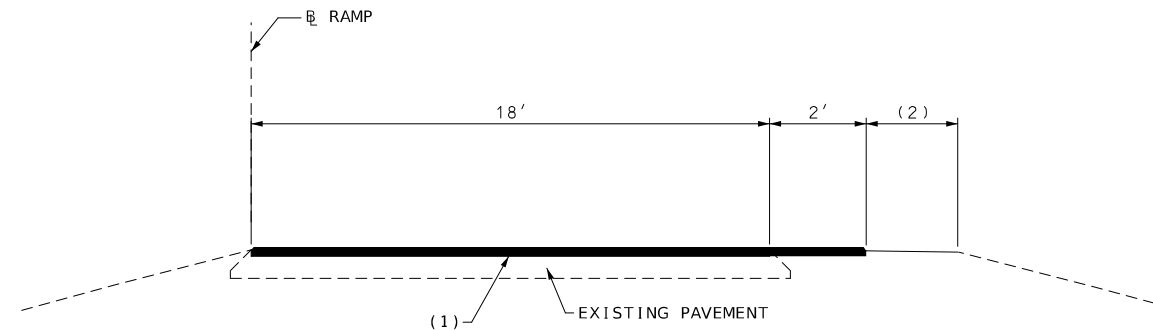

- (1)
COLDMILL EXISTING PAVEMENT (WBL-2.75") OR (EBL-2") DEPTH
OVERLAY 2" SUPERPAVE ASPHALT (SP125B PG 76-22)
WITH 0.75" TYPE C ULTRATHIN BONDED WEARING SURFACE
- (2)
BITUMINOUS FOG SEAL ON REMAINING ASPHALT
SHOULDER WIDTH.

INTERCHANGE RAMP

ROUTE Y

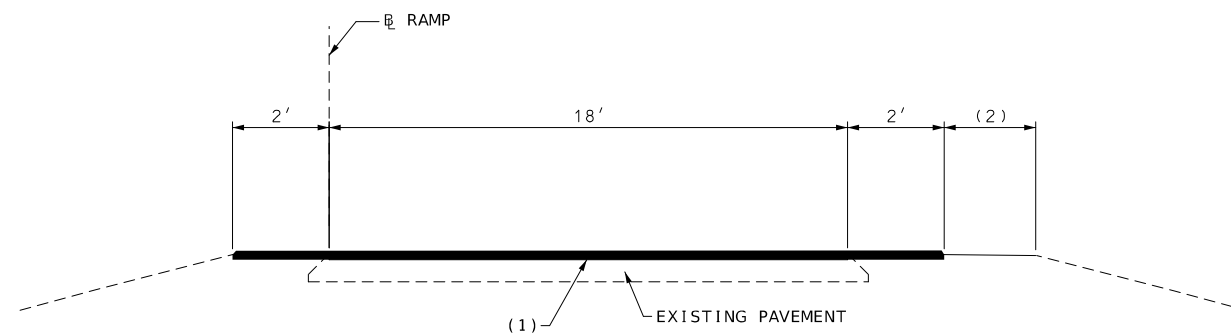

- (1)
COLDMILL EXISTING PAVEMENT (WBL-2.75") OR (EBL-2") DEPTH
OVERLAY 2" SUPERPAVE ASPHALT (SP125B PG 76-22)
WITH 0.75" TYPE C ULTRATHIN BONDED WEARING SURFACE
- (2)
BITUMINOUS FOG SEAL ON REMAINING ASPHALT
SHOULDER WIDTH.

INTERCHANGE RAMP

ROUTES A/B



DATE PREPARED
11/12/2024

ROUTE 1-70 STATE MO
DISTRICT NE SHEET NO. 2

COUNTY
WARREN/MONTGOMERY

JOB NO.
J213309
CONTRACT ID.

PROJECT NO.

BRIDGE NO.

DESCRIPTION	DATE

MISSOURI HIGHWAYS AND TRANSPORTATION COMMISSION

105 WEST CAPITOL
JEFFERSON CITY, MO 65102
1-888-ASK-MODOT (1-888-275-6636)

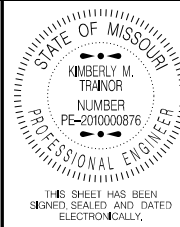

DATE PREPARED
8/12/2024
ROUTE
1-70 STATE
MO
DISTRICT SHEET NO.
NW 3
COUNTY
MONTGOMERY/WARREN
JOB NO.
J213309
CONTRACT ID.

PROJECT NO.

BRIDGE NO.

DESCRIPTION	DATE

MISSOURI HIGHWAYS AND TRANSPORTATION COMMISSION

105 WEST CAPITOL
JEFFERSON CITY, MO 65102
1-888-ASK-MODOT (1-888-275-6636)

D2B5
QUANTITY SHEET
SHEET 3 OF 3

SIGN	SIZE	AREA	QTY	TOTAL AREA	QTY RELOC	TOTAL RELOC	SIGN NUM.	DESCRIPTION
SIGN	IN.	SQ. FT.	EACH	SQ. FT.	EACH	SQ. FT.		
WARNING SIGNS								
WO1-1L	48X48	16.00						TURN (SYMBOL LEFT)
WO1-1R	48X48	16.00						TURN (SYMBOL RIGHT)
WO1-2L	48X48	16.00						CURVE (SYMBOL LEFT)
WO1-2R	48X48	16.00						CURVE (SYMBOL RIGHT)
WO1-3L	48X48	16.00						REVERSE TURN (SYMBOL LEFT)
WO1-3R	48X48	16.00						REVERSE TURN (SYMBOL RIGHT)
WO1-4L	48X48	16.00						REVERSE CURVE (SYMBOL LEFT)
WO1-4R	48X48	16.00						REVERSE CURVE (SYMBOL RIGHT)
WO1-4bL	48X48	16.00						DOUBLE ARROW REVERSE CURVE (SYMBOL LEFT)
WO1-4bR	48X48	16.00						DOUBLE ARROW REVERSE CURVE (SYMBOL RIGHT)
WO1-4cL	48X48	16.00						TRIPLE ARROW REVERSE CURVE (SYMBOL LEFT)
WO1-4cR	48X48	16.00						TRIPLE ARROW REVERSE CURVE (SYMBOL RIGHT)
WO1-6	60X30	12.50						HORIZONTAL ARROW (SYMBOL)
WO1-6a	72X36	18.00						HORIZ. ARROW (SYMBOL ON PERMANENT BARRICADE)
WO1-7	60X30	12.50						DOUBLE HEAD HORIZONTAL ARROW (SYMBOL)
WO1-7a	72X36	18.00						DOUBLE HEAD HORIZ. ARROW (SYMBOL ON PERM. BARR.)
WO1-8	18X24	3.00						CHEVRON (SYMBOL)
WO1-8a	30X36	7.50						CHEVRON (SYMBOL FOR DIVIDED HIGHWAYS)
WO3-1	48X48	16.00						STOP AHEAD (SYMBOL)
WO3-2	48X48	16.00	2	32			40	YIELD AHEAD (SYMBOL)
WO3-3	48X48	16.00						SIGNAL AHEAD (SYMBOL)
WO3-4	48X48	16.00						BE PREPARED TO STOP
WO3-5	48X48	16.00						SPEED LIMIT AHEAD
WO4-1L	48X48	16.00						MERGE (SYMBOL FROM LEFT)
WO4-1R	48X48	16.00	2	32			44	MERGE (SYMBOL FROM RIGHT)
WO4-1aL	48X48	16.00	2	32			6A	MERGE (LEFT)
WO4-1aR	48X48	16.00	2	32			6A	MERGE (RIGHT)
WO5-1	48X48	16.00	2	32			43	ROAD/BRIDGE/RAMP NARROWS
WO5-3	48X48	16.00						ONE LANE BRIDGE
WO5-5	48X48	16.00						NARROW LANES
WO6-1	48X48	16.00						DIVIDED HIGHWAY (SYMBOL)
WO6-2	48X48	16.00						DIVIDED HIGHWAY END (SYMBOL)
WO6-3	48X48	16.00						TWO WAY TRAFFIC (SYMBOL)
WO7-3a	30X24	5.00						NEXT XX MILES (PLAQUE)
WO8-1	48X48	16.00						BUMP
WO8-2	48X48	16.00						DIP
WO8-3	48X48	16.00						PAVEMENT ENDS
WO8-4	48X48	16.00						SOFT SHOULDER
WO8-5	48X48	16.00						SLIPPERY WHEN WET (SYMBOL)
WO8-6	48X48	16.00						TRUCK CROSSING
WO8-6c	48X48	16.00						TRUCK ENTRANCE
WO8-7	36X36	9.00						LOOSE GRAVEL
WO8-7a	36X36	9.00						FRESH OIL / LOOSE GRAVEL
WO8-9	48X48	16.00						LOW SHOULDER
WO8-11	48X48	16.00						UNEVEN LANES
WO8-12	48X48	16.00						NO CENTER LINE
WO8-15	48X48	16.00						GROOVED PAVEMENT
WO8-15P	30X24	5.00						MOTORCYCLE (PLAQUE)
WO8-17L	48X48	16.00						SHOULDER DROP-OFF (SYMBOL LEFT)
WO8-17R	48X48	16.00						SHOULDER DROP-OFF (SYMBOL RIGHT)
WO8-17P	30X24	5.00						SHOULDER DROP-OFF (PLAQUE)
WO10-1	42RND.	9.62						RAILROAD CROSSING
WO12-1	24X24	4.00						DOUBLE DOWN ARROW (SYMBOL)
WO12-2	48X48	16.00						LOW CLEARANCE (SYMBOL)
WO12-2x	24X18	3.00						LOW CLEARANCE (PLAQUE)
WO12-2a	84X24	14.00						OVERHEAD LOW CLEARANCE (FEET AND INCHES)
WO12-4	120X60	50.00						LOW CLEARANCE XX FT XX IN XX MILES AHEAD
WO12-5	120X60	50.00						WIDTH RESTRICTION XX FT XX IN XX MILES AHEAD
WO13-1	30X30	6.25						ADVISORY SPEED (PLAQUE)
WO16-2	30X24	5.00						XXX FEET (PLAQUE)
WO16-3	30X24	5.00						X MILE (PLAQUE)
WO20-1	48X48	16.00	13	208			2	ROAD/BRIDGE/RAMP WORK AHEAD
WO20-2	48X48	16.00						DETOUR AHEAD
WO20-3	48X48	16.00	4	64			7 & 8	ROAD CLOSED AHEAD
WO20-4	48X48	16.00						ONE LANE ROAD AHEAD
WO20-5	48X48	16.00	4	64			5	RIGHT/CENTER/LEFT LANE CLOSED AHEAD
WO20-5a	48X48	16.00						2 RIGHT/CENTER/LEFT LANES CLOSED AHEAD
WO20-6a	48X48	16.00	2	32			6	RIGHT/CENTER/LEFT LANE CLOSED
WO20-7a	48X48	16.00						FLAGGER (SYMBOL)
WO21-2	36X36	9.00						FRESH OIL
WO21-5	48X48	16.00						SHOULDER WORK / SHOULDER WORK AHEAD
WO22-1	48X48	16.00						BLASTING ZONE AHEAD
WO22-2	42X36	10.50						TURN OFF 2-WAY RADIO AND PHONE
WO22-3	42X36	10.50						END BLASTING ZONE
GO22-1	21X15	2.19	2	4.38				WET PAINT (ARROW PIVOTS)

SIGN	SIZE	AREA	QTY	TOTAL AREA	QTY RELOC	TOTAL RELOC	SIGN NUM.	DESCRIPTION
SIGN	IN.	SQ. FT.	EACH	SQ. FT.	EACH	SQ. FT.		
GUIDE SIGNS								
E05-1	36X48	12.00	2	24			49	GORE EXIT
E05-2	48X36	12.00						EXIT OPEN
E05-2a	48X36	12.00	2	24			55	EXIT CLOSED
GO20-1	60X24	10.00	4	40			1	ROAD WORK NEXT XX MILES
GO20-2	48X24	8.00	4	32			26	END ROAD WORK
GO20-4	36X18	4.50						PILOT CAR FOLLOW ME
GO20-4a	42X30	8.75						PILOT CAR IN USE WAIT & FOLLOW
GO20-4a	18X12	1.50						PILOT CAR IN USE WAIT & FOLLOW
GO20-5aP	36X24	6.00	8	48			54	WORK ZONE (PLAQUE)
MO4-8a	24X18	3.00						END DETOUR
MO4-9L	48X36	12.00						DETOUR (LEFT)
MO4-9R	48X36	12.00						DETOUR (RIGHT)
MO4-9P	48X12	4.00						STREET NAME (PLAQUE)
MO4-10L	48X18	6.00						DETOUR ARROW (LEFT)
MO4-10R	48X18	6.00						DETOUR ARROW (RIGHT)
REGULATORY SIGNS								
R1-1	48X48	13.25						STOP
R1-2	48TR1	6.93	2	13.86			13	YIELD
R1-2a	36X36	9.00						TO ONCOMING TRAFFIC (PLAQUE)
R1-3P	30X12	2.50						ALL WAY (PLAQUE)
R2-1	36X48	12.00	8	96			4 & 25	SPEED LIMIT XX
R3-1	48X48	16.00						NO RIGHT TURN (SYMBOL)
R3-2	48X48	16.00						NO LEFT TURN (SYMBOL)
R3-3	36X36	9.00						NO TURNS
R3-4	48X48	16.00						NO U-TURN (SYMBOL)
R3-7L	30X30	6.25						LEFT LANE MUST TURN LEFT
R3-7R	30X30	6.25						RIGHT LANE MUST TURN RIGHT
R4-1	36X48	12.00	4	48			46	DO NOT PASS
R4-2	36X48	12.00	4	48			46A	PASS WITH CARE
R4-7a	36X48	12.00						KEEP RIGHT (HORIZONTAL ARROW)
R4-8a	36X48	12.00						KEEP LEFT (HORIZONTAL ARROW)
R5-1	30X30	6.25						DO NOT ENTER
R5-1a	36X24	6.00						WRONG WAY
R6-1L	54X18	6.75						ONE WAY ARROW (LEFT)
R6-1R	54X18	6.75						ONE WAY ARROW (RIGHT)
R6-2L	24X30	5.00						ONE WAY (LEFT)
R6-2R	24X30	5.00						ONE WAY (RIGHT)
R9-9	24X12	2.00						SIDEWALK CLOSED
R9-11L	24X18	3.00						SIDEWALK CLOSED AHEAD, (ARROW LEFT) CROSS HERE
R9-11R	24X18	3.00						SIDEWALK CLOSED AHEAD, (ARROW RIGHT) CROSS HERE
R10-6	24X36	6.00						STOP HERE ON RED (45° ARROW)
R11-2	48X30	10.00						ROAD CLOSED
R11-3a	60X30	12.50						ROAD CLOSED XX MILES AHEAD
R11-4	60X30	12.50						LOCAL TRAFFIC ONLY
CONST-3A	60X48	20.00	4	80			53	FINE SIGN
CONST-3X	56X12	4.67	4	18.68				SPEEDING/PASSING (PLATE)
MISCELLANEOUS SIGNS								
CONST-5	48X36	12.00						POINT OF PRESENCE
CONST-5	96X48	32.00	2	64			57	POINT OF PRESENCE
CONST-8	48X36	12.00	4	48			56	WORK ZONE NO PHONE ZONE
616-10.05					TOTAL			
CONSTRUCTION SIGNS					1117			
616-10.10					TOTAL			
RELOCATED SIGNS					0			

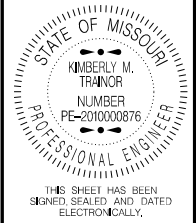

DATE PREPARED
11/12/2024

ROUTE STATE
I - 70 MO

DISTRICT SHEET NO.
NE 4

COUNTY
MONTGOMERY/WARREN

JOB NO.
J213309

CONTRACT ID.

PROJECT NO.

BRIDGE NO.

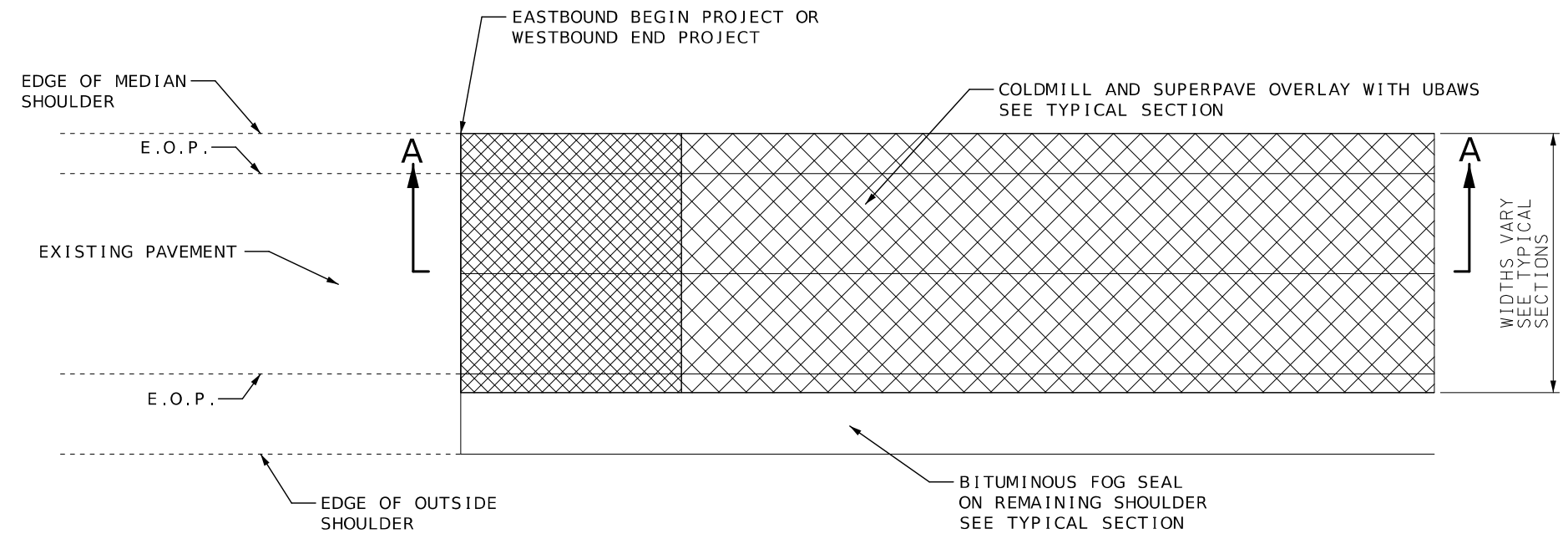

PLAN VIEW

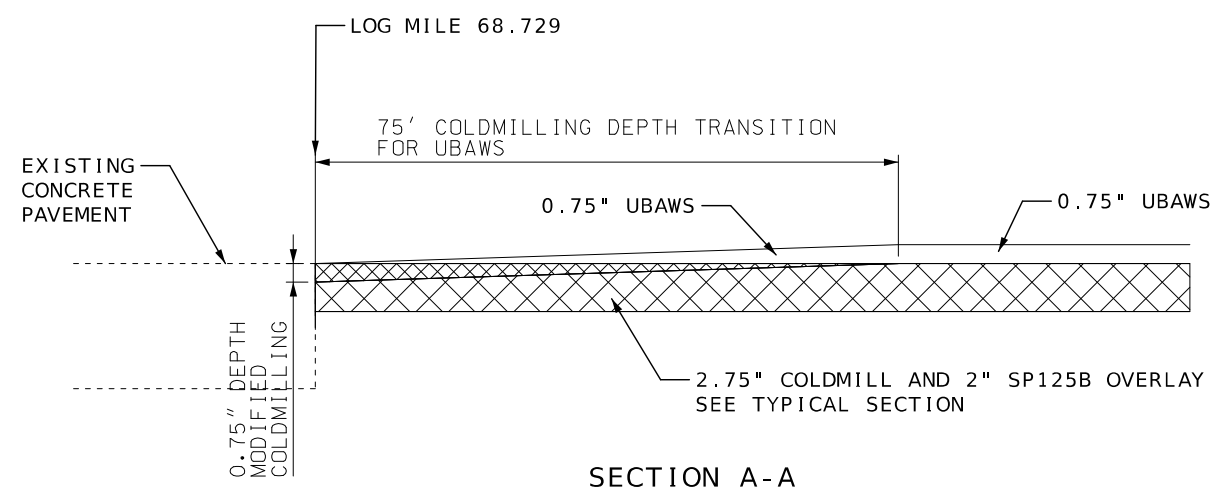

SECTION A-A
WESTBOUND LANES
END OF PROJECT

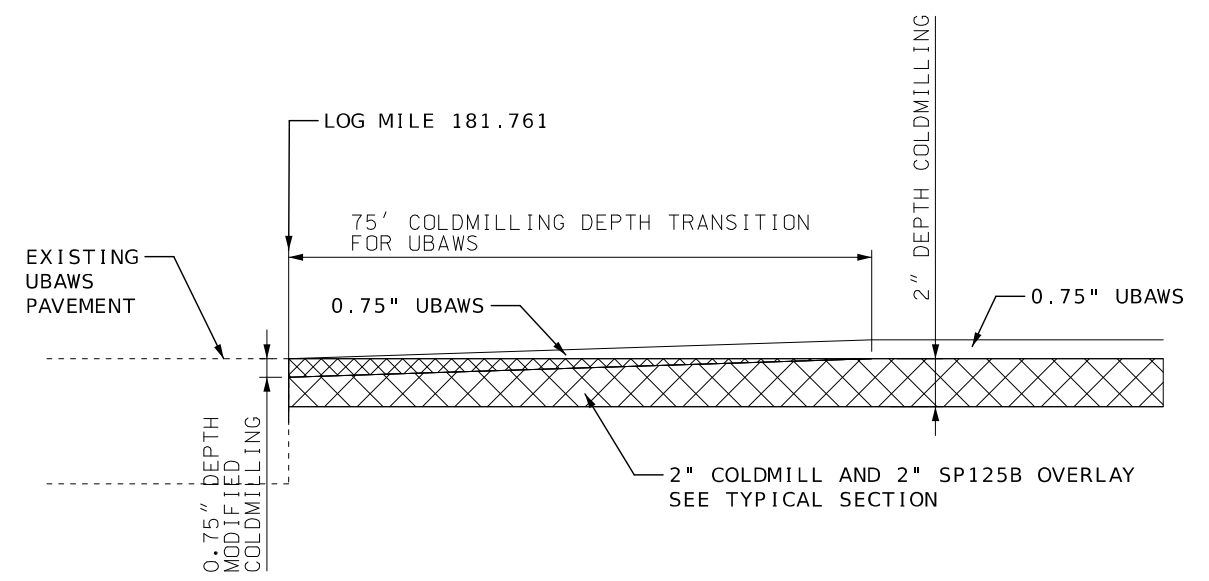

SECTION A-A
EASTBOUND LANES
BEGIN OF PROJECT

DATE	DESCRIPTION

MISSOURI HIGHWAYS AND TRANSPORTATION COMMISSION

105 WEST CAPITOL
JEFFERSON CITY, MO 65102
1-888-ASK-MODOT (1-888-275-6636)

SPECIAL SHEET
DEPTH TRANSITIONS
BEGIN OR END OF PROJECT
SHEET 1 OF 5

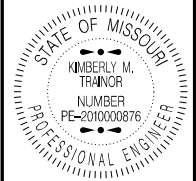

THIS SHEET HAS BEEN SIGNED, SEALED AND DATED ELECTRONICALLY.

DATE PREPARED
11/12/2024

ROUTE STATE
I - 70 MO

DISTRICT SHEET NO.
NE 5

COUNTY
MONTGOMERY/WARREN

JOB NO.
J213309

CONTRACT ID.

PROJECT NO.

BRIDGE NO.

DESCRIPTION	DATE

MISSOURI HIGHWAYS AND TRANSPORTATION COMMISSION

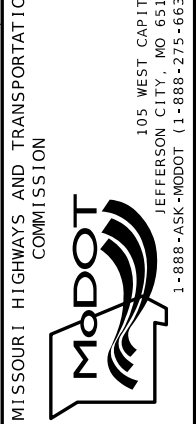

SPECIAL SHEET
DEPTH TRANSITIONS
AT ROUTE MM INTERCHANGE
SHEET 2 OF 5

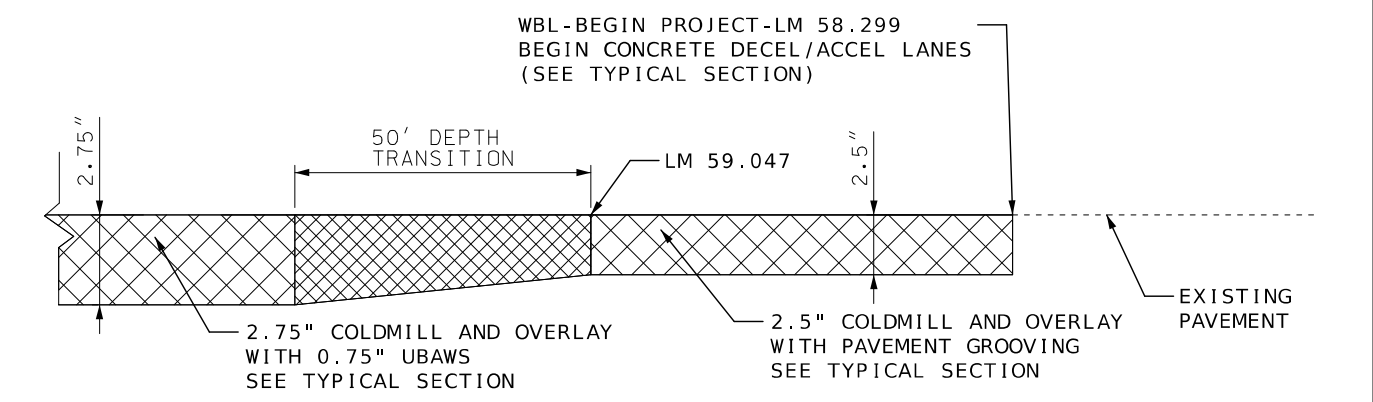
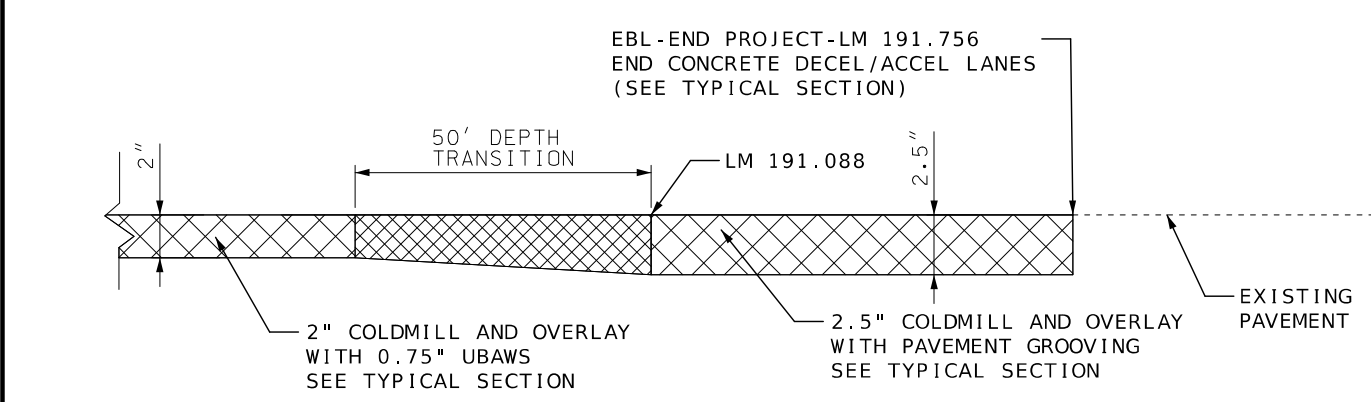
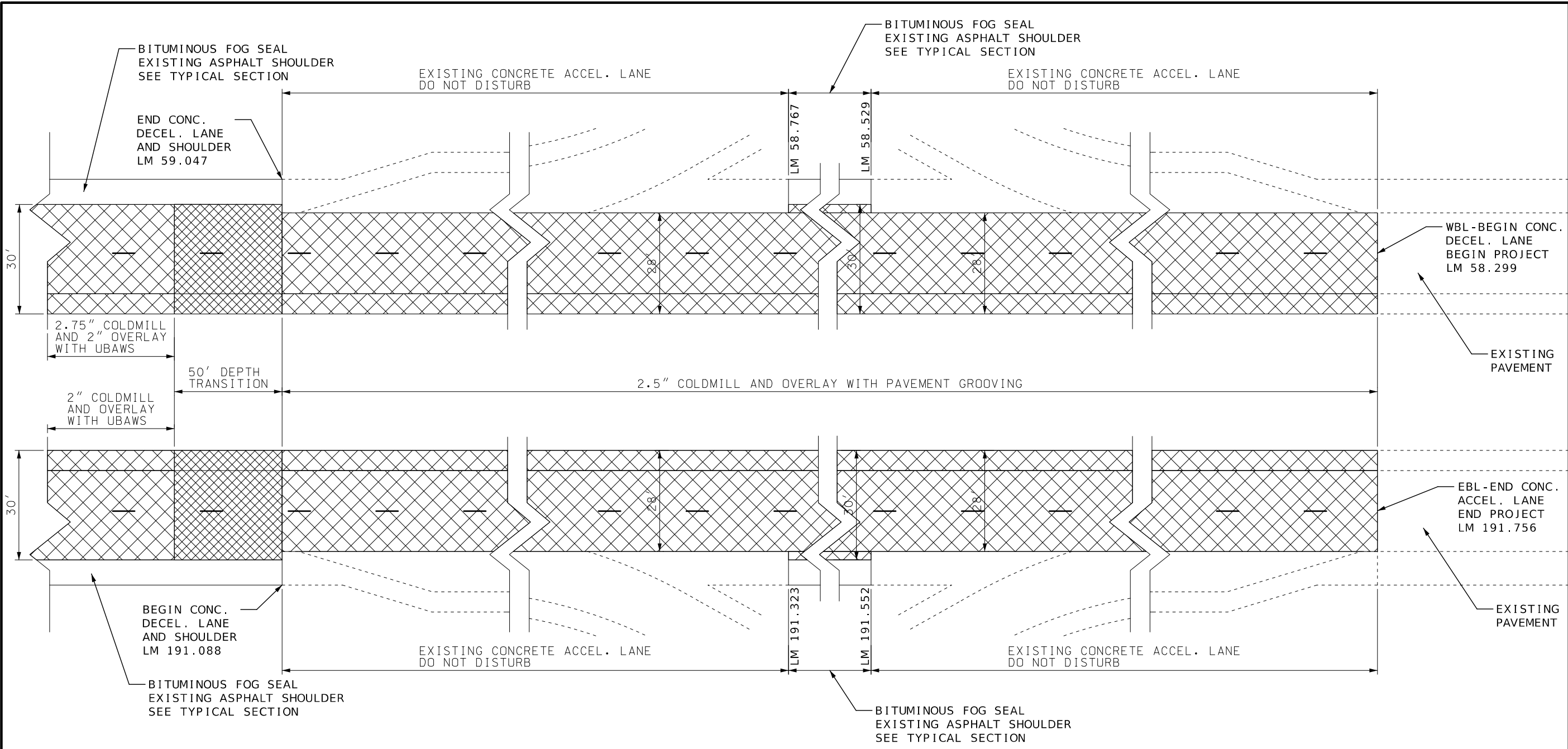

NOTE: SEE SHEET 6 FOR DEPTH TRANSITION FROM 0.75" UBAs TO PAVEMENT GROOVING.

EASTBOUND LANES AT ROUTE MM INTERCHANGE ADJACENT TO DECEL AND ACCEL LANES

NOTE: SEE SHEET 6 FOR DEPTH TRANSITION FROM 0.75" UBAs TO PAVEMENT GROOVING.

WESTBOUND LANES AT ROUTE MM INTERCHANGE ADJACENT TO DECEL AND ACCEL LANES

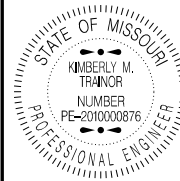

THIS SHEET HAS BEEN SIGNED, SEALED AND DATED ELECTRONICALLY.

DATE PREPARED
11/12/2024

ROUTE STATE
1-70 MO

DISTRICT SHEET NO.
NE 6

COUNTY
MONTGOMERY/WARREN

JOB NO.
J213309

CONTRACT ID.

PROJECT NO.

BRIDGE NO.

DESCRIPTION

DATE

DESCRIPTION

DATE

DESCRIPTION

DATE

DESCRIPTION

DATE

DESCRIPTION

DATE

DESCRIPTION

DATE

DESCRIPTION

DATE

DESCRIPTION

DATE

DESCRIPTION

DATE

DESCRIPTION

DATE

DESCRIPTION

DATE

DESCRIPTION

DATE

DESCRIPTION

DATE

DESCRIPTION

DATE

DESCRIPTION

DATE

DESCRIPTION

DATE

DESCRIPTION

DATE

DESCRIPTION

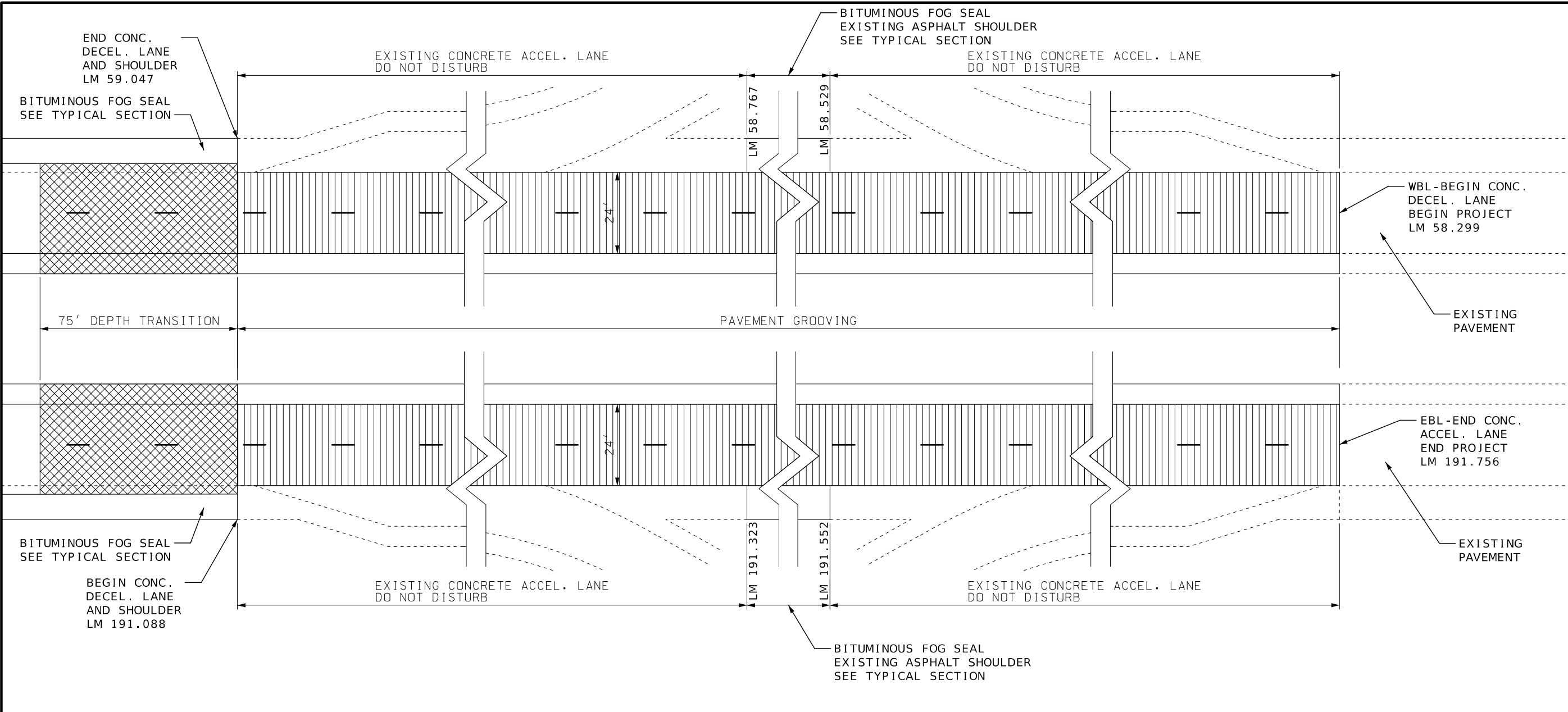

EASTBOUND OR WESTBOUND LANES AT ROUTE MM INTERCHANGE
SPECIAL CONDITION FOR PAVEMENT GROOVING ADJACENT TO
CONCRETE DECEL AND ACCEL LANES THAT WILL NOT BE DISTURBED

 MODIFIED COLDMILLING AND 0.75" UBAWS
 SP125B WITH PAVEMENT GROOVING

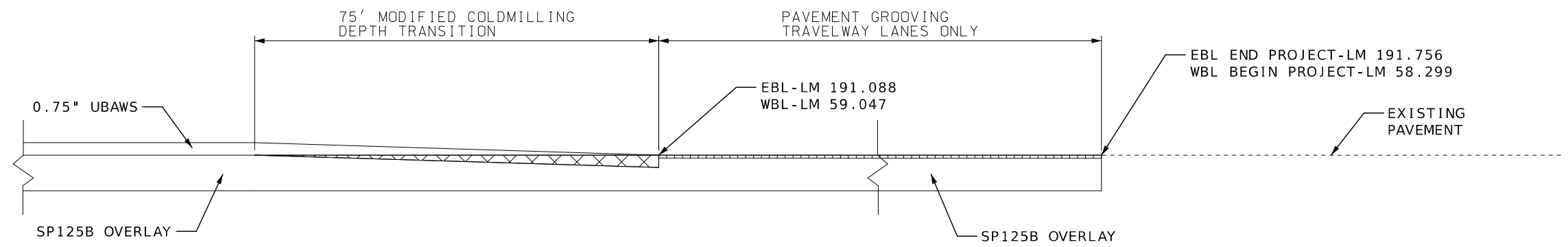

NOT TO SCALE

DEPTH TRANSITION FROM 0.75" UBAWS TO PAVEMENT GROOVING
AT ROUTE MM INTERCHANGE

MISSOURI HIGHWAYS AND TRANSPORTATION COMMISSION



105 WEST CAPITOL
JEFFERSON CITY, MO 65102
1-888-ASK-MODOT (1-888-275-6636)

SPECIAL SHEET
DEPTH TRANSITION
AT ROUTE MM INTERCHANGE
SHEET 3 OF 5

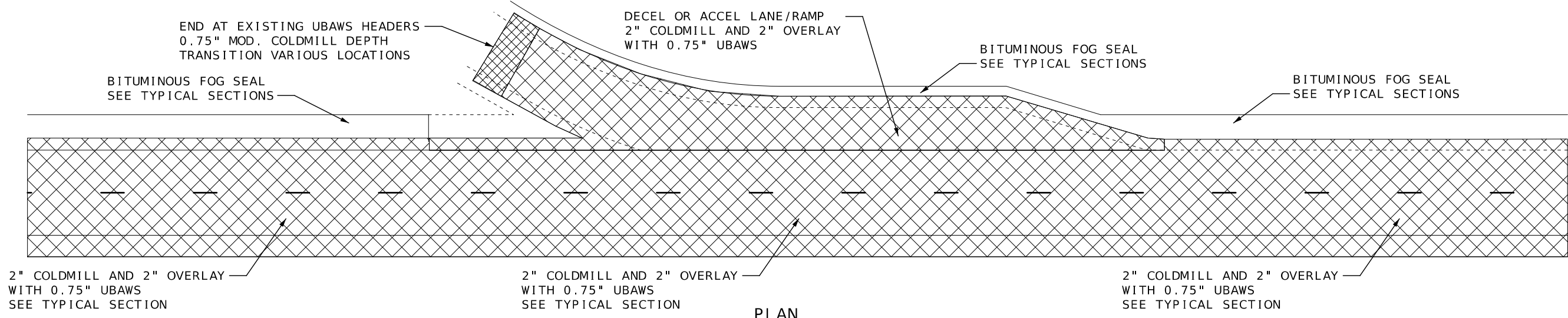

PLAN
EASTBOUND LANES AT ROUTES Y AND A/B INTERCHANGES
WITH ASPHALT DECEL AND ACCEL LANES

- 0" TO 0.75" MODIFIED COLDMILLING DEPTH TRANSITION FOR UBAWS
- FULL DEPTH COLDMILLING FOR SP125B OVERLAY

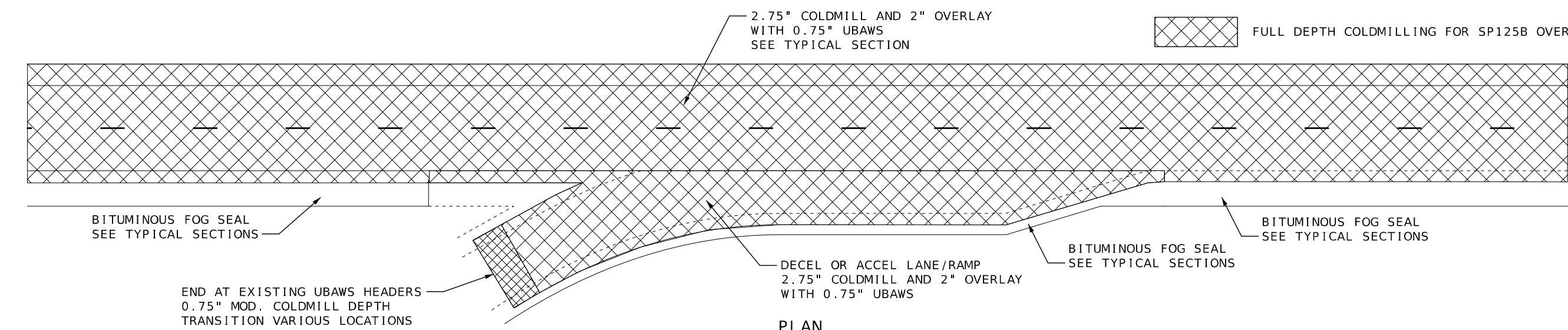

PLAN
WESTBOUND LANES AT ROUTES Y AND A/B INTERCHANGES
WITH ASPHALT DECEL AND ACCEL LANES

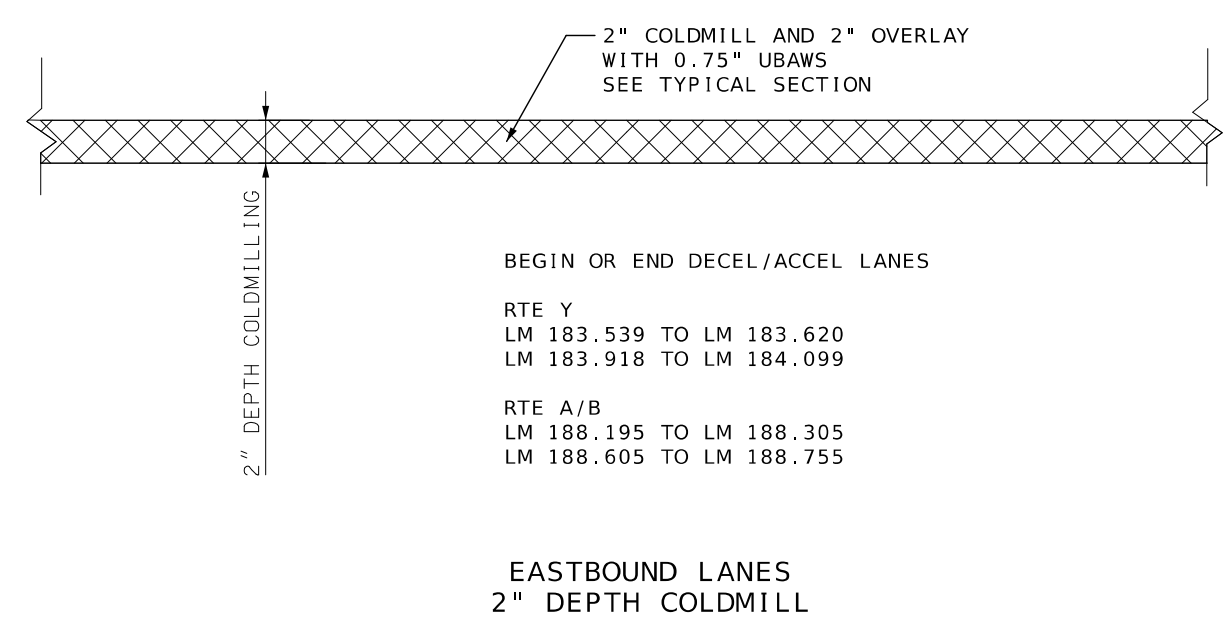
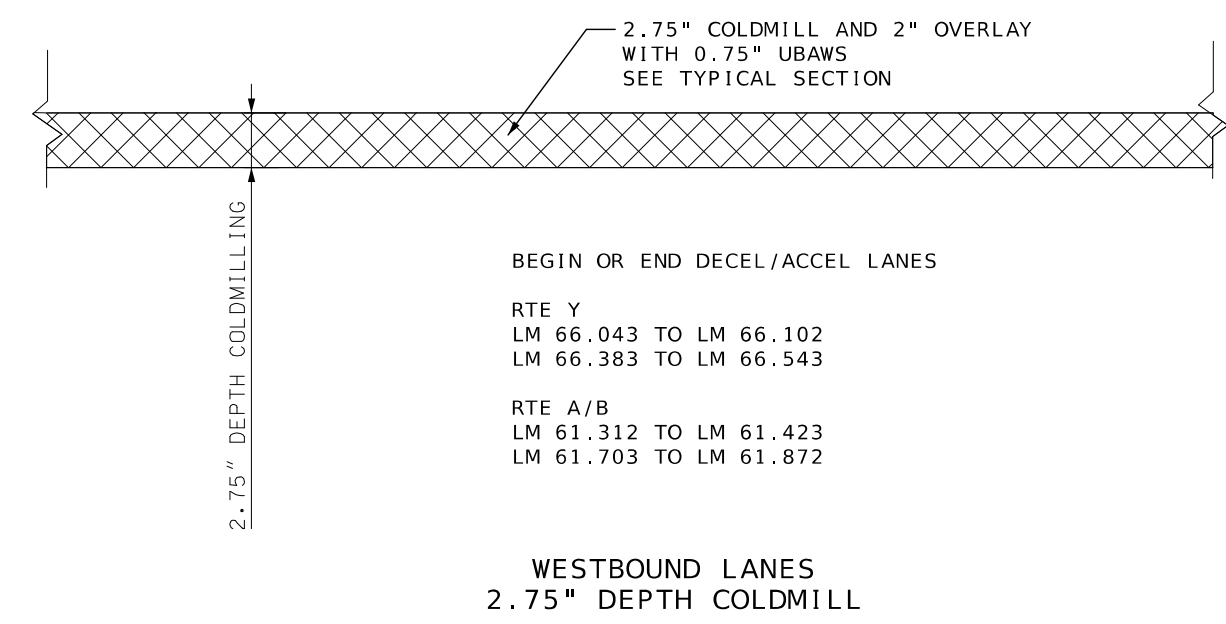

BEGIN OR END DECEL/ACCEL LANES

RTE Y
LM 66.043 TO LM 66.102
LM 66.383 TO LM 66.543

RTE A/B
LM 61.312 TO LM 61.423
LM 61.703 TO LM 61.872

BEGIN OR END DECEL/ACCEL LANES

RTE Y
LM 183.539 TO LM 183.620
LM 183.918 TO LM 184.099

RTE A/B
LM 188.195 TO LM 188.305
LM 188.605 TO LM 188.755

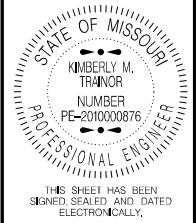

DATE PREPARED		11/12/2024	
ROUTE	STATE	1 - 70	MO
DISTRICT	SHEET NO.	NE	8
COUNTY			
MONTGOMERY/WARREN			
JOB NO.			
J213309			
CONTRACT ID.			
PROJECT NO.			
BRIDGE NO.			

DESCRIPTION	DATE

MISSOURI HIGHWAYS AND TRANSPORTATION COMMISSION

105 WEST CAPITOL
JEFFERSON CITY, MO 65102
1-888-ASK-MODOT (1-888-275-6636)

SPECIAL SHEET
DEPTH TRANSITIONS AT ROUTES
Y, A/B, AND 47 INTERCHANGES
SHEET 5 OF 5

SIGN AND DEVICE SPACING AND CHANNELIZING TAPER LENGTHS

TAPER LENGTHS AND SPACING OF CHANNELIZING DEVICES					
SPEED MPH	MINIMUM TAPER LENGTHS (L) FOR LANE WIDTHS (W)			MAXIMUM CHANNELIZER SPACING (FT)	
	10 FT	11 FT	12 FT	THROUGH TAPER	THROUGH WORK AREA
0-35	205	225	245	35	40
40-45	450	495	540	40	80
50-55	550	605	660	50	80
60-70	700	770	840	60	120

LONGITUDINAL BUFFER SPACE (B)	
SPEED MPH	BUFFER SPACE (FEET)
0-35	280
40-45	400
50-55	560
60-70	840

SIGN SPACING (S) FOR ADVANCE SIGN SERIES (1) (2)		
SPEED MPH	UNDIVIDED HIGHWAYS (FT)	DIVIDED HIGHWAYS (FT)
0-35	200	200
40-45	350	500
50-55	500	1000
60-70	1000	SA-1000 SB-1500 SC-2640

NOTES:

DIMENSIONS IN FEET UNLESS OTHERWISE NOTED.

- (1) SPACING BETWEEN SIGNS AND SPACING BETWEEN LAST SIGN AND FLAGGER, BEGINNING OF TAPER, OR SIGNED CONDITION
- (2) SPACINGS MAY BE ADJUSTED AS NECESSARY TO MEET FIELD CONDITIONS

TAPER LENGTH (L):

L = WS FOR 40 MPH OR MORE
 L = $\frac{WS^2}{60}$ FOR 35 MPH OR LESS
 FOR SHOULDER TAPER USE L/3









WHERE:

L = TAPER LENGTH IN FEET
 W = LATERAL SHIFT IN FEET
 S = POSTED SPEED IN MPH

TRAFFIC CONTROL DEVICES

GENERAL NOTES:

1. SEE STANDARD PLAN 616.10 FOR DETAILS AND ITEMS NOT SHOWN
2. EXISTING SIGNS SHALL BE COVERED DURING WORKING HOURS ONLY IF IN CONFLICT WITH TRAFFIC CONTROL PLANS.
3. NO DIRECT PAYMENT WILL BE MADE FOR RELOCATING, COVERING, UNCOVERING OR REMOVING SIGNS.
4. CONES ALLOWABLE FOR DAYTIME OPERATIONS ONLY.
6. LOCATE FLASHING ARROW PANEL AT BEGINNING OF TAPER WHEN FEASIBLE, ARROW PANELS ARE ALWAYS LOCATED BEHIND CHANNELIZERS OR CONES.

TRAFFIC CONTROL LEGEND			
	SIGN (SINGLE SIDED)		CHANNELIZER
	SIGN (DOUBLE SIDED)		BARRICADE
	FLAGGER		CHANGEABLE MESSAGE BOARD
	DIRECTIONAL INDICATOR BARRICADE		TRUCK MOUNTED ATTENUATOR W/ FLASHING ARROW
	DIRECTIONAL INDICATOR BARRICADE WITH SEQUENTIAL FLASHING WARNING LIGHT		

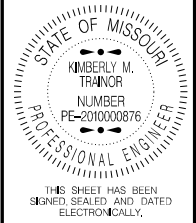

DATE PREPARED
8/12/2024

ROUTE STATE
I-70 MO

DISTRICT SHEET NO.
NE 9

COUNTY
MONTGOMERY/WARREN

JOB NO.
J213309

CONTRACT ID.

PROJECT NO.

BRIDGE NO.

DESCRIPTION	DATE

MISSOURI HIGHWAYS AND TRANSPORTATION COMMISSION



105 WEST CAPITOL JEFFERSON CITY, MO 65102
1-888-ASK-MODOT (1-888-275-6636)

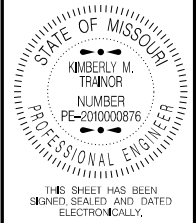

DATE PREPARED
11/12/2024

ROUTE STATE
I-70 MO

DISTRICT SHEET NO.
NE 10

COUNTY
MONTGOMERY/WARREN

JOB NO.
J213309

CONTRACT ID.

PROJECT NO.

BRIDGE NO.

DESCRIPTION	DATE

MISSOURI HIGHWAYS AND TRANSPORTATION COMMISSION

105 WEST CAPITOL JEFFERSON CITY, MO 65102
1-888-ASK-MODOT (1-888-275-6636)

BEGIN/END PROJECT AND STATE ROUTES TRAFFIC CONTROL SHEET 2 OF 7

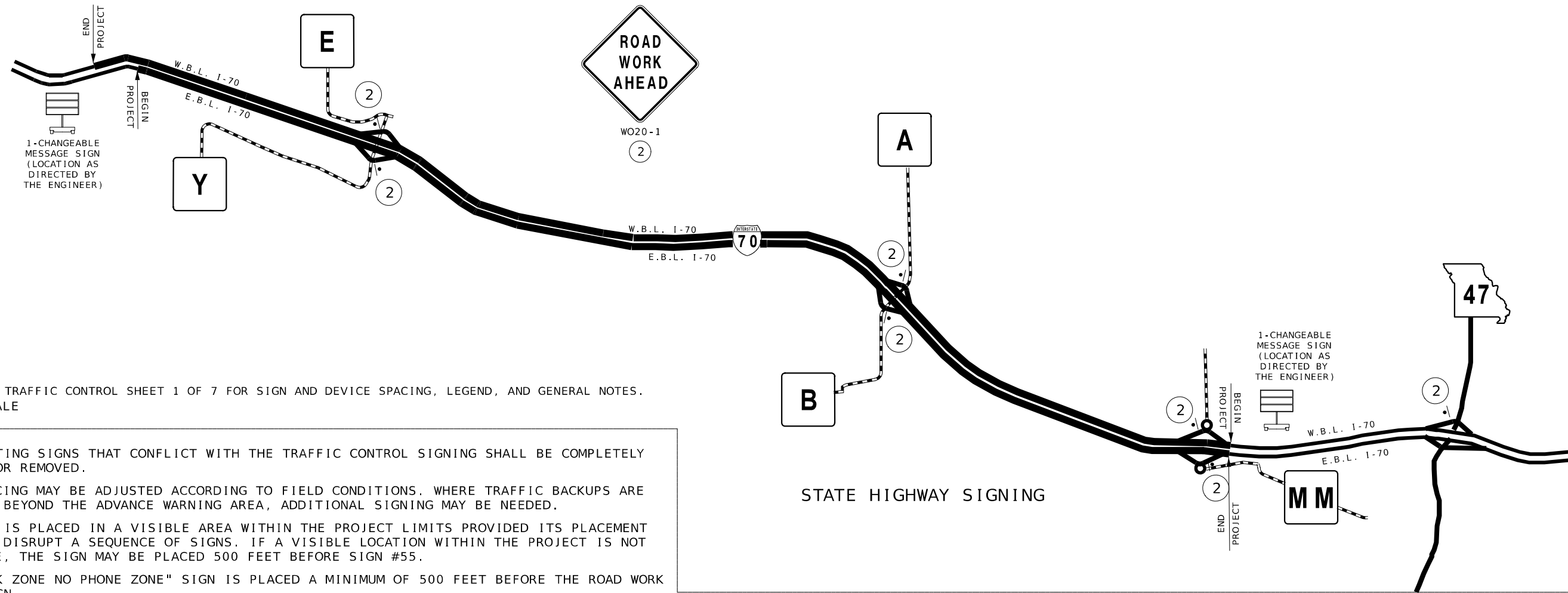

NOTE: SEE TRAFFIC CONTROL SHEET 1 OF 7 FOR SIGN AND DEVICE SPACING, LEGEND, AND GENERAL NOTES. NOT TO SCALE

ANY EXISTING SIGNS THAT CONFLICT WITH THE TRAFFIC CONTROL SIGNING SHALL BE COMPLETELY COVERED OR REMOVED.

SIGN SPACING MAY BE ADJUSTED ACCORDING TO FIELD CONDITIONS. WHERE TRAFFIC BACKUPS ARE EXPECTED BEYOND THE ADVANCE WARNING AREA, ADDITIONAL SIGNING MAY BE NEEDED.

SIGN #57 IS PLACED IN A VISIBLE AREA WITHIN THE PROJECT LIMITS PROVIDED ITS PLACEMENT DOES NOT DISRUPT A SEQUENCE OF SIGNS. IF A VISIBLE LOCATION WITHIN THE PROJECT IS NOT AVAILABLE, THE SIGN MAY BE PLACED 500 FEET BEFORE SIGN #55.

THE "WORK ZONE NO PHONE ZONE" SIGN IS PLACED A MINIMUM OF 500 FEET BEFORE THE ROAD WORK AHEAD SIGN.

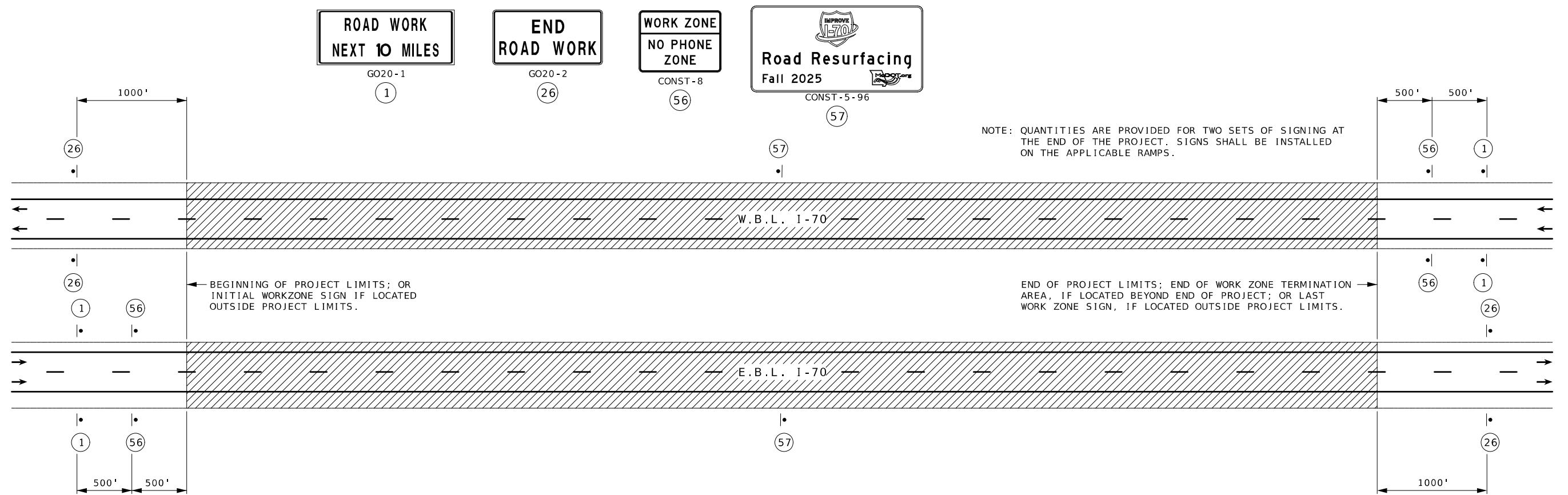

NOTE: QUANTITIES ARE PROVIDED FOR TWO SETS OF SIGNING AT THE END OF THE PROJECT. SIGNS SHALL BE INSTALLED ON THE APPLICABLE RAMP.

BEGINNING OF PROJECT LIMITS; OR INITIAL WORKZONE SIGN IF LOCATED OUTSIDE PROJECT LIMITS.

END OF PROJECT LIMITS; END OF WORK ZONE TERMINATION AREA, IF LOCATED BEYOND END OF PROJECT; OR LAST WORK ZONE SIGN, IF LOCATED OUTSIDE PROJECT LIMITS.

NOT TO SCALE

BEGINNING AND END OF PROJECT SIGNING

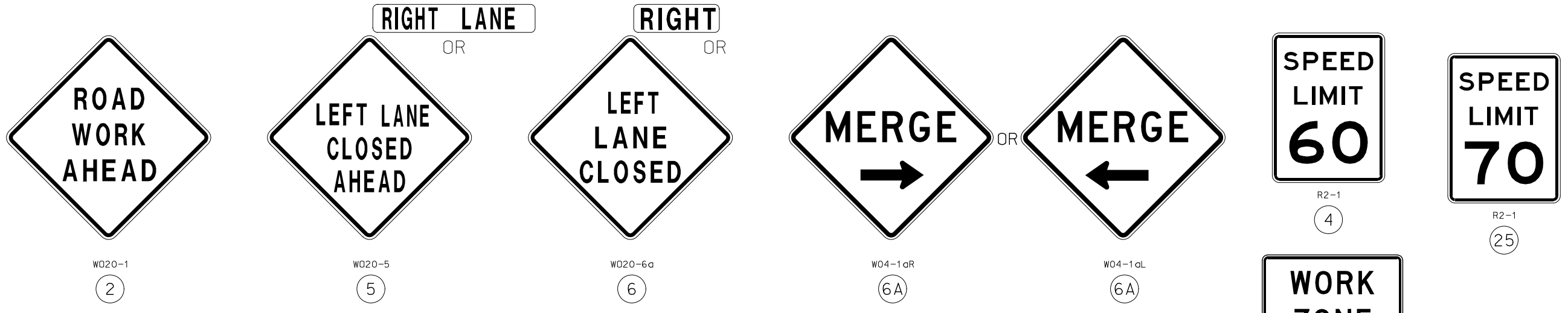
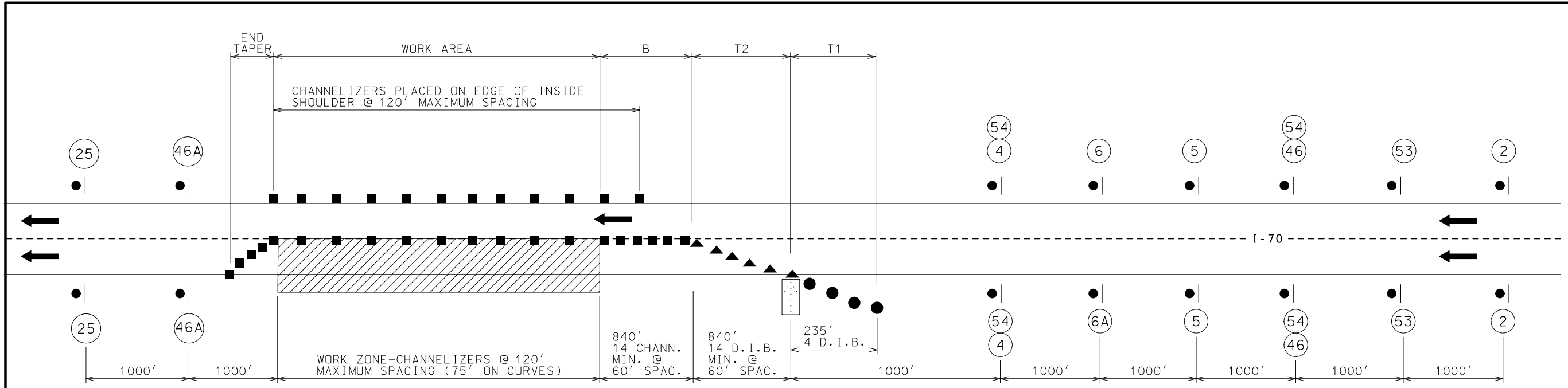

NOTE: SEE TRAFFIC CONTROL SHEET 1 OF 7 FOR SIGN AND DEVICE SPACING AND OTHER GENERAL NOTES.
LEFT LANE CLOSURE SHOWN.

TRAFFIC CONTROL LEGEND

- DIRECTIONAL INDICATOR BARRICADE WITHOUT SEQUENTIAL FLASHING WARNING LIGHT
- ▶ DIRECTIONAL INDICATOR BARRICADE WITH SEQUENTIAL FLASHING WARNING LIGHT
- CHANNELIZER (TRIM-LINE)
- | SIGN
- ⋯ FLASHING ARROW PANEL

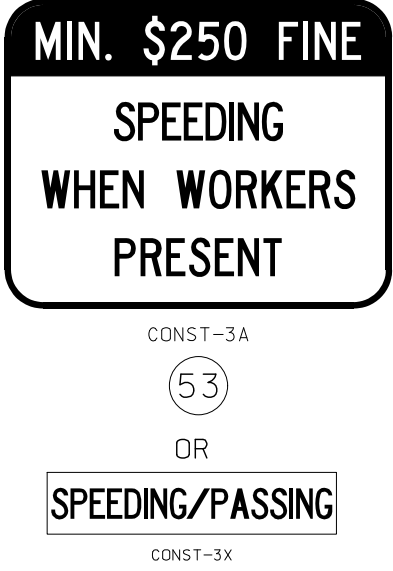

STATE OF MISSOURI
KIMBERLY M. TRINOR
NUMBER PE-201000876
PROFESSIONAL ENGINEER

THIS SHEET HAS BEEN SIGNED, SEALED AND DATED ELECTRONICALLY.

DATE PREPARED 8/12/2024

ROUTE I-70 STATE MO

DISTRICT NE SHEET NO. 11

COUNTY MONTGOMERY / WARREN

JOB NO. J213309

CONTRACT ID.

PROJECT NO.

BRIDGE NO.

DESCRIPTION	DATE

MISSOURI HIGHWAYS AND TRANSPORTATION COMMISSION

105 WEST CAPITOL JEFFERSON CITY, MO 65102
1-888-ASK-MODOT (1-888-275-6636)

MoDOT

RIGHT OR LEFT LANE CLOSURE TRAFFIC CONTROL SHEET 3 OF 7



W020-1
2

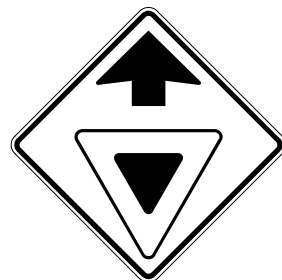

W03-2a
40



R1-2
13



W05-1
43



W04-1R
55

TRAFFIC CONTROL LEGEND

- DIRECTIONAL INDICATOR BARRICADE WITHOUT SEQUENTIAL FLASHING WARNING LIGHT
- ▶ DIRECTIONAL INDICATOR BARRICADE WITH SEQUENTIAL FLASHING WARNING LIGHT
- CHANNELIZER (TRIM-LINE)
- | SIGN
- ⋯ FLASHING ARROW PANEL

NOTE: SEE TRAFFIC CONTROL SHEET 1 OF 7 FOR SIGN AND DEVICE SPACING AND OTHER GENERAL NOTES.

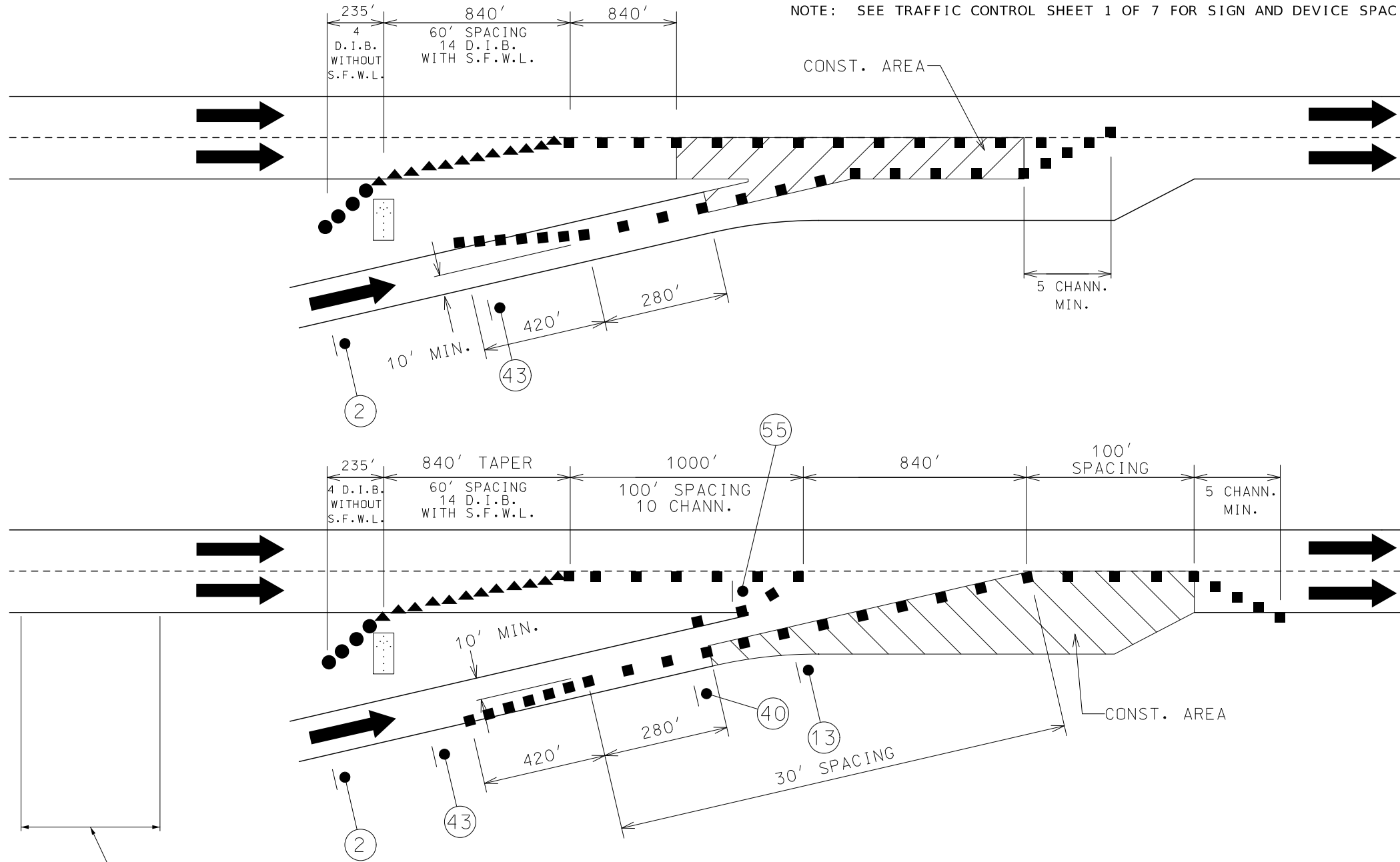

SEE SHEETS 6 AND 7 FOR SIGNAGE AND TEMPORARY RUMBLE STRIPS PLACEMENT.

WORK IN THE VICINITY OF AN ENTRANCE RAMP

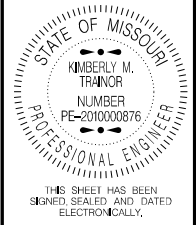

DATE PREPARED: 8/12/2024
 ROUTE: I-70 STATE: MO
 DISTRICT: NE SHEET NO.: 12
 COUNTY: MONTGOMERY/WARREN
 JOB NO.: J213309
 CONTRACT ID.:
 PROJECT NO.:
 BRIDGE NO.:

DESCRIPTION	DATE

MISSOURI HIGHWAYS AND TRANSPORTATION COMMISSION

105 WEST CAPITOL
JEFFERSON CITY, MO 65102
1-888-ASK-MODOT (1-888-273-6636)

ENTRANCE RAMP WORK
 TRAFFIC CONTROL
 SHEET 4 OF 7



W05-1
43



E05-1
49

TRAFFIC CONTROL LEGEND

- DIRECTIONAL INDICATOR BARRICADE WITHOUT SEQUENTIAL FLASHING WARNING LIGHT
- ▶ DIRECTIONAL INDICATOR BARRICADE WITH SEQUENTIAL FLASHING WARNING LIGHT
- CHANNELIZER (TRIM-LINE)
- | SIGN
- ⋯ FLASHING ARROW PANEL

NOTE: SEE TRAFFIC CONTROL SHEET 1 OF 7 FOR SIGN AND DEVICE SPACING AND OTHER GENERAL NOTES.

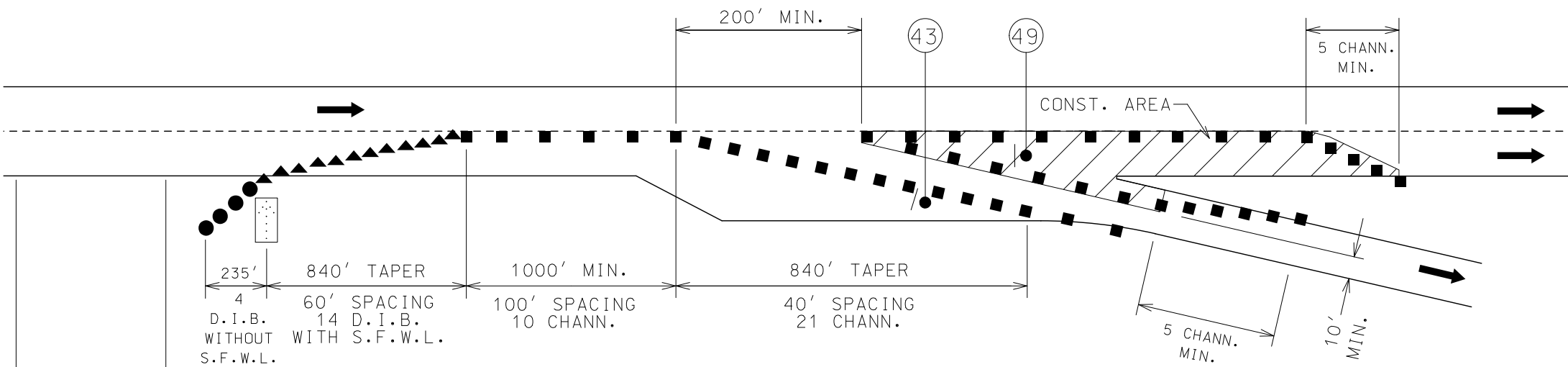
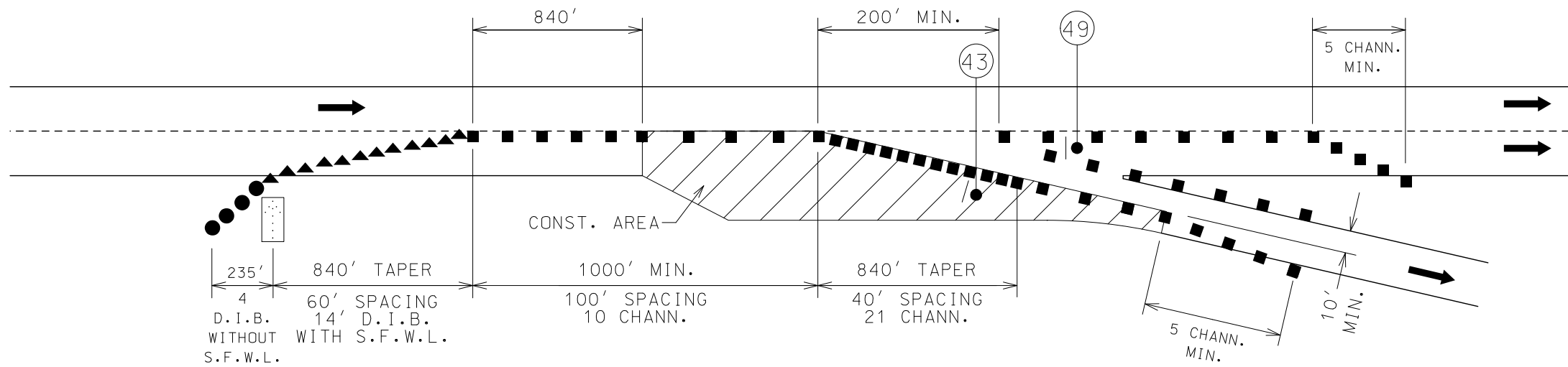

SEE SHEETS 6 AND 7 FOR SIGNAGE AND TEMPORARY RUMBLE STRIPS PLACEMENT.

WORK IN THE VICINITY OF AN EXIT RAMP

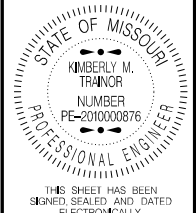

DATE PREPARED
8/12/2024
ROUTE STATE
I-70 MO
DISTRICT SHEET NO.
NE 13
COUNTY
MONTGOMERY/WARREN
JOB NO.
J213309
CONTRACT ID.
PROJECT NO.
BRIDGE NO.

DESCRIPTION	DATE

MISSOURI HIGHWAYS AND TRANSPORTATION COMMISSION
MoDOT
105 WEST CAPITOL
JEFFERSON CITY, MO 65102
1-888-ASK-MODOT (1-888-275-6636)

EXIT RAMP WORK
TRAFFIC CONTROL
SHEET 5 OF 7

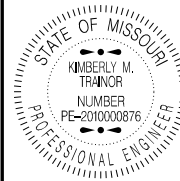

THIS SHEET HAS BEEN SIGNED, SEALED AND DATED ELECTRONICALLY.

DATE PREPARED
8/12/2024

ROUTE STATE
1-70 MO

DISTRICT SHEET NO.
NE 14

COUNTY
MONTGOMERY/WARREN

JOB NO.
J213309

CONTRACT ID.

PROJECT NO.

BRIDGE NO.

DATE	DESCRIPTION

MISSOURI HIGHWAYS AND TRANSPORTATION COMMISSION



105 WEST CAPITOL JEFFERSON CITY, MO 65102 1-888-ASK-MODOT (1-888-275-6636)

RAMP CLOSURE TRAFFIC CONTROL SHEET 6 OF 7



RAMP

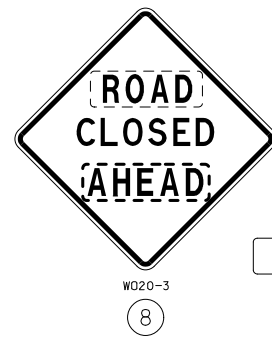

RAMP 500 FT

EXIT CLOSED

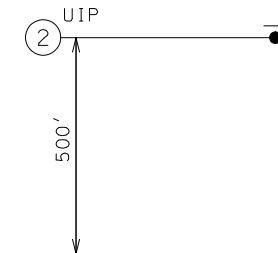

8

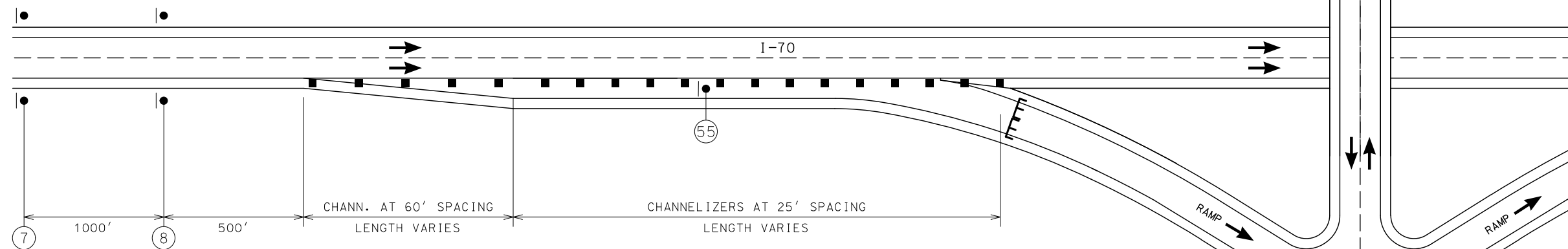

- TRAFFIC CONTROL LEGEND
- E TYPE III MOVEABLE BARRICADE
 - CHANNELIZER (TRIM-LINE)
 - SIGN

NOTE: SEE TRAFFIC CONTROL SHEET 1 OF 7 FOR SIGN AND DEVICE SPACING, LEGEND, AND OTHER GENERAL NOTES.

TYPICAL RAMP CLOSURE

PAVEMENT MARKING EQUIPMENT

ADVANCE WARNING TRUCK WITH WORK SIGNS, FLASHING ARROW PANEL AND TRUCK OR TRAILER MOUNTED ATTENUATOR. (1)

ADVANCE WARNING TRUCK WITH WORK SIGNS, FLASHING ARROW PANEL AND TRUCK OR TRAILER MOUNTED ATTENUATOR. (2)

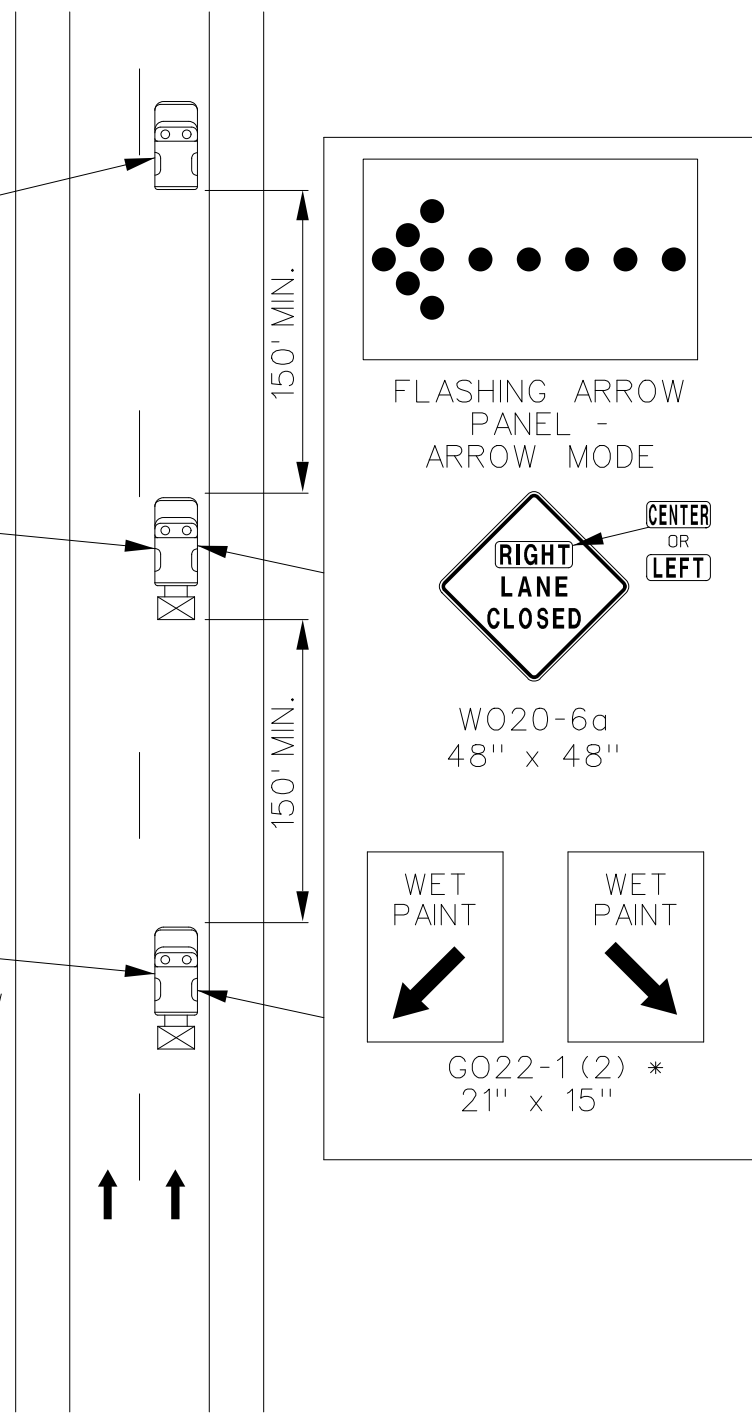

Multi-Lane Divided Highway

- (1) WET PAINT SIGNS ARE INSTALLED TO INDICATE THE SIDE IN WHICH THE PAVEMENT MARKING MATERIAL IS BEING APPLIED. AT THE CONTRACTOR'S OPTION, A FRONT FACING WET PAINT SIGN MAY BE INSTALLED ON THE LEFT SIDE OF THE PAVEMENT MARKING EQUIPMENT.
- (2) ADVANCE WARNING TRUCK IS POSITIONED AT THE NO TRACK POINT OF THE PAVEMENT MARKING MATERIAL OR SPACING SHOWN, WHICHEVER IS GREATER.

SEE TRAFFIC CONTROL STANDARD 616.35a (TA-35a) FOR DETAILS.

NOTE:
* REMOVE DURING RUMBLE STRIP INSTALLATION



Road Resurfacing

Fall 2025

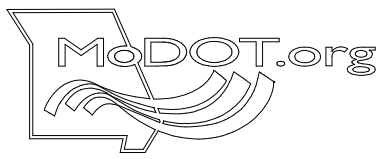

36.125	23.75	36.125
6.5	21.25	6.25
6.5	11.25	5
6.5	16.625	27
6.5	55.5	23.125
6.5	96	6.5

CONST-5-96 SH-FLAT SHEET;
3.000" Radius, 0.750" Border, White on, Blue;
Improve I-70; "Road Resurfacing", D; "Fall 2025", D;
Table of letter and object lefts

36.125														
R	o	a	d	R	e	s	u	r	f	a	c	i	n	g
6.500	12.750	18.125	23.875	34.000	40.250	45.375	51.125	57.375	61.125	65.000	70.625	76.500	79.875	85.500
F	a	i	l	l	2	0	2	5						
6.500	10.125	14.500	17.000	22.750	27.000	31.500	36.000	66.375						

Completed as Promised

25	2.5	5.125	2.5	21.875
1.5	1.5	60	1.5	1.5

CONST-5P-60 SHF-FLAT SHEET FLUORESCENT; 1.500" Radius, No border, Yellow;
[Completed as Promised] Black D 65% spacing;
Table of letter and object lefts.

C	o	m	p	i	e	t	e	d	a	s
1.500	4.875	7.875	12.375	15.375	16.625	19.375	21.500	24.250	29.000	31.875
P	r	o	m	i	s	e	d			
36.625	39.875	41.875	44.875	49.500	50.750	53.500	56.250			

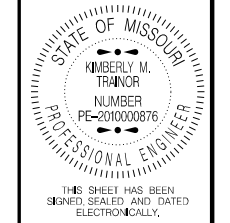

DATE PREPARED 11/12/2024	
ROUTE I-70	STATE MO
DISTRICT NE	SHEET NO. 15
COUNTY MONTGOMERY/WARREN	
JOB NO. J213309	
CONTRACT ID.	
PROJECT NO.	
BRIDGE NO.	

DESCRIPTION	DATE

MISSOURI HIGHWAYS AND TRANSPORTATION COMMISSION



105 WEST CAPITOL JEFFERSON CITY, MO 65102
1-888-ASK-MODOT (1-888-275-6636)

MOVING OPERATION STRIPING/
SPECIAL SIGNS
TRAFFIC CONTROL
SHEET 7 OF 7