

DESIGN DESIGNATION

A.A.D.T. - 2024 = 80
 A.A.D.T. - 2025 = 83
 D.H.V. = 7.5%
 T = 10%
 V = 55 M.P.H.
 D = 50%/50%

FUNCTIONAL CLASSIFICATION - MINOR COLLECTOR

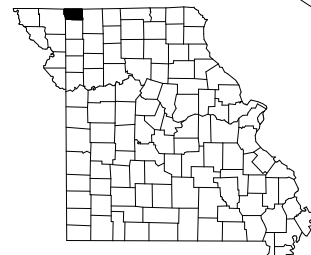

KEY MAP
LOCATION OF WORTH COUNTY

NO RIGHT OF WAY ACQUISITION

CONVENTIONAL SYMBOLS
(USED IN PLANS)

	EXISTING	NEW
BUILDINGS AND STRUCTURES		
GUARD RAIL		
GUARD CABLE		
CONCRETE RIGHT-OF-WAY MARKER		
STEEL RIGHT-OF-WAY MARKER		
LOCATION SURVEY MARKER		
UTILITIES		
FIBER OPTICS	-FO-	-FO-
OVERHEAD CABLE TV	-OTV-	-OTV-
UNDERGROUND CABLE TV	-UTV-	-UTV-
OVERHEAD TELEPHONE	-OT-	-OT-
UNDERGROUND TELEPHONE	-UT-	-UT-
OVERHEAD POWER	-OE-	-OE-
UNDERGROUND POWER	-UE-	-UE-
SANITARY SEWER	-S-	-S-
STORM SEWER	-SS-	-SS-
GAS	-G-	-G-
WATER	-W-	-W-
MANHOLE		
FIRE HYDRANT		
WATER VALVE		
WATER METER		
DROP INLET		
DITCH BLOCK		
GROUND MOUNTED SIGN		
LIGHT POLE		
H-FRAME POWER POLE		
TELEPHONE PEDESTAL		
FENCE		
CHAIN LINK		
WOVEN WIRE		
GATE POST		
BENCHMARK		

NOTE: DASHED OR OPEN SYMBOLS INDICATE EXISTING FEATURES

MISSOURI HIGHWAYS AND TRANSPORTATION COMMISSION PLANS FOR PROPOSED STATE HIGHWAY WORTH COUNTY

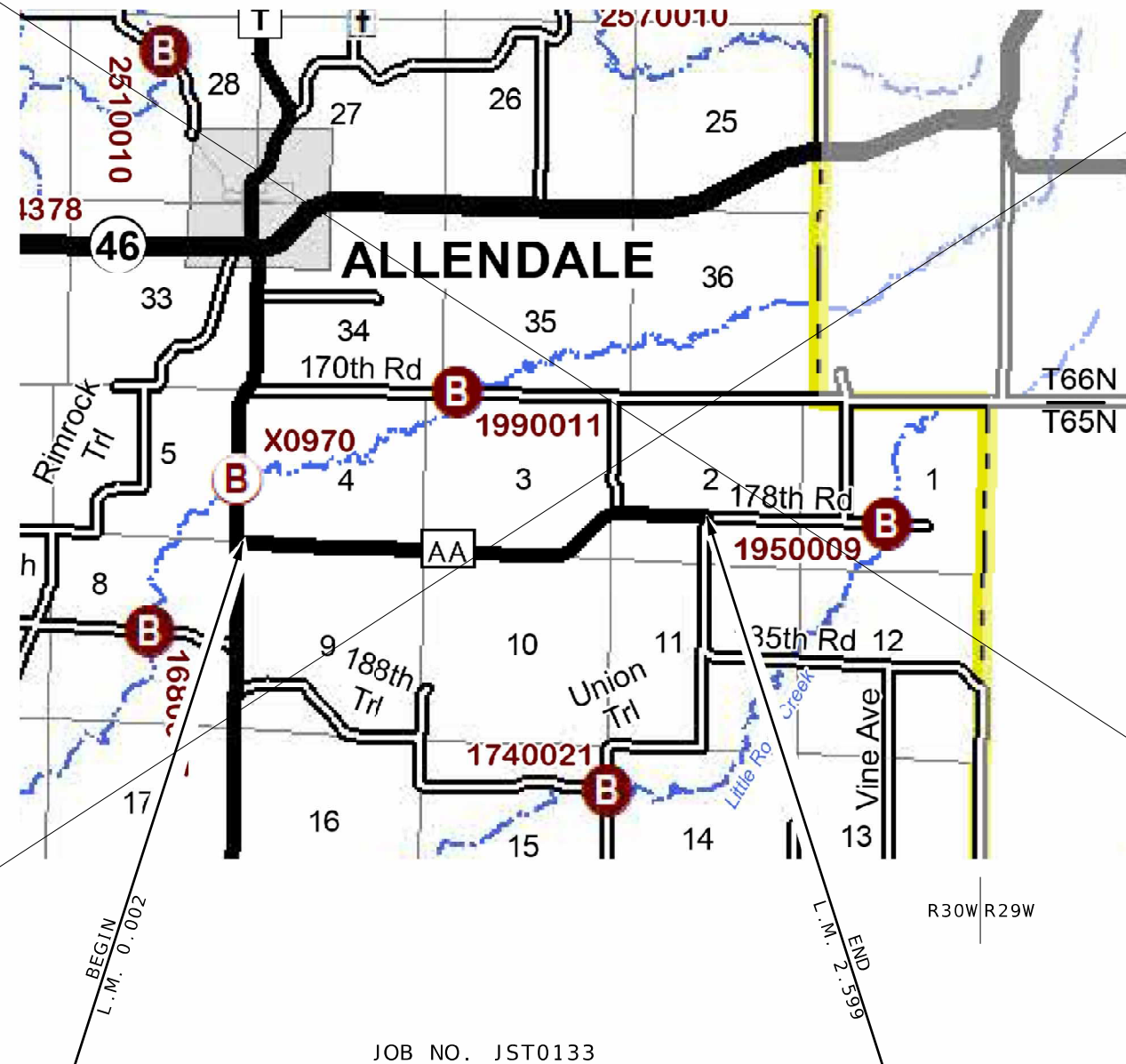

JOB NO. JST0133
1 IN. ASPHALT RESURFACING (LEVEL COURSE)
LENGTH = 2.597 MILES

NOT TO SCALE

THE EXISTENCE AND APPROXIMATE LOCATION OF UTILITY FACILITIES KNOWN TO EXIST, AS SHOWN ON THE PLANS, ARE BASED ON THE BEST INFORMATION AVAILABLE TO THE COMMISSION AT THIS TIME. THIS INFORMATION IS PROVIDED BY THE COMMISSION "AS-IS" AND THE COMMISSION EXPRESSLY DISCLAIMS ANY REPRESENTATION OR WARRANTY AS TO THE COMPLETENESS, ACCURACY, OR SUITABILITY OF THE INFORMATION FOR ANY USE. RELIANCE UPON THIS INFORMATION IS DONE AT THE RISK AND PERIL OF THE USER, AND THE COMMISSION SHALL NOT BE LIABLE FOR ANY DAMAGES THAT MAY ARISE FROM ANY ERROR IN THE INFORMATION. IT IS, THEREFORE, THE RESPONSIBILITY OF THE CONTRACTOR TO VERIFY THE EXISTENCE, LOCATION AND STATUS OF ANY FACILITY. SUCH VERIFICATION INCLUDES DIRECT CONTACT WITH THE LISTED UTILITIES.

SHEET DELETED

INDEX OF SHEETS

DESCRIPTION	SHEET NUMBER
TITLE SHEET	1
TYPICAL SECTIONS (TS) (1 SHEET)	2
QUANTITIES (QU) (2 SHEETS)	3
SPECIAL SHEETS (SS) (2 SHEETS)	4-5
TRAFFIC CONTROL SHEETS (TC)	6

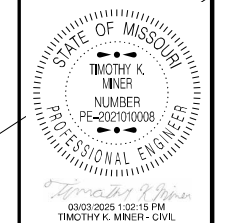

DATE PREPARED
3/3/2025
ROUTE AA STATE MO
DISTRICT NW SHEET NO. 1
COUNTY WORTH
JOB NO. JST0133
CONTRACT ID.
PROJECT NO.
BRIDGE NO.

DATE	DESCRIPTION
2/28/2025	SHEET DELETED.

LENGTH OF PROJECT

BEGINNING OF PROJECT	L.M. 0.002
END OF PROJECT	L.M. 2.599
APPARENT LENGTH	2.597 MILES
EQUATIONS AND EXCEPTIONS:	

TOTAL CORRECTIONS	0 MILES
NET LENGTH OF PROJECT	2.597 MILES
STATE LENGTH	2.597 MILES
FOR INFORMATION ONLY ESTIMATED DISTURBED ACRES	0 ACRES

MISSOURI HIGHWAYS AND TRANSPORTATION COMMISSION

 105 WEST CAPITOL
 JEFFERSON CITY, MO 65102
 1-888-ASK-MODOT (1-888-275-6636)

*NOTE:
PAVING WILL BE DONE AT FULL WIDTH
OF THE ROADWAY TO ELIMINATE CENTERLINE
JOINT.

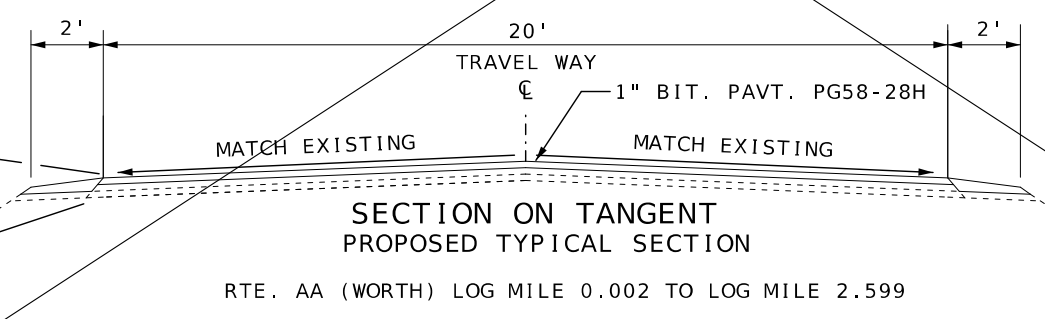
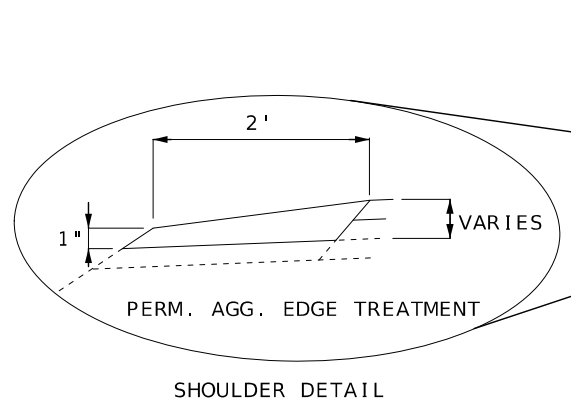
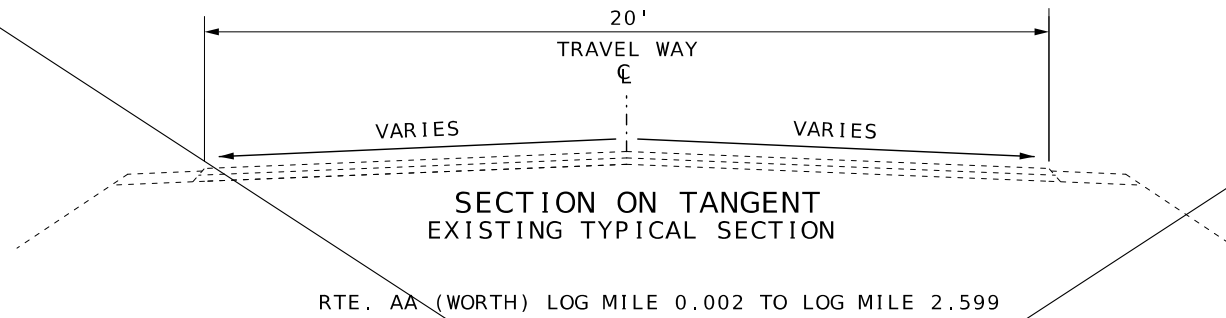

ESTIMATE FACTORS *

DESCRIPTION	FACTOR
BITUMINOUS PAVEMENT MIXTURE PG58-28H SURFACE LEVELING	1.98 TONS/CY
TACK COAT	EXISTING PAVEMENT 0.08 GAL/SY MILLED SURFACE 0.10 GAL/SY
GRAVEL A OR CRUSHED STONE B	1.6 TONS/CY
PERMANENT AGGREGATE EDGE TREATMENT	1.6 TONS/CY

* FOR INFORMATION PURPOSES ONLY

NOT TO SCALE

1 SHEET DELETED
TYPICAL SECTIONS
SHEET 1 OF 1

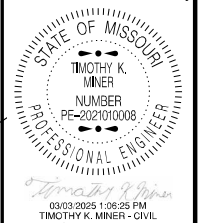

DATE PREPARED
3/3/2025
ROUTE AA STATE MO
DISTRICT NW SHEET NO. 2
COUNTY WORTH
JOB NO. JST0133
CONTRACT ID.
PROJECT NO.
BRIDGE NO.

DATE	DESCRIPTION
2/28/2025	SHEET DELETED.

MISSOURI HIGHWAYS AND TRANSPORTATION
COMMISSION
105 WEST CAPITOL
JEFFERSON CITY, MO 65102
1-888-ASK-MODOT (1-888-275-6636)

REV.

GRAVEL (A) CRUSHED STONE (B)					
FACTOR	LENGTH (FT)	WIDTH (FT)	DEPTH (IN.)	TONS	REMARKS
1.6 TONS/CY	10	20	2	13.83	7 LOCATIONS
PAY TOTAL				14	

STANDARD WATERBORNE PAVEMENT MARKING PAINT, TYPE P BEADS					
LOG MILE		ROUTE	LENGTH (FT)	4" INT. YELLOW (FT)	4" SOLID YELLOW (FT)
FROM	TO				
0.002	0.050	AA	253.44	0	506.88
0.050	0.190	AA	739.2	184.8	739.2
0.190	0.217	AA	142.56	0	285.12
0.217	0.357	AA	739.2	184.8	739.2
0.357	0.366	AA	47.52	0	95.04
0.366	0.460	AA	496.32	124.08	496.32
0.460	0.539	AA	417.12	0	834.24
0.539	0.635	AA	506.88	126.72	506.88
0.635	0.818	AA	966.24	0	1932.48
0.818	0.979	AA	850.08	212.52	850.08
0.979	1.009	AA	158.4	39.6	0
1.009	1.205	AA	1034.88	258.72	1034.88
1.205	1.335	AA	686.4	0	1372.8
1.335	1.504	AA	892.32	223.08	892.32
1.504	1.546	AA	221.76	55.44	0
1.546	1.698	AA	802.56	200.64	802.56
1.698	2.278	AA	3062.4	0	6124.8
2.278	2.598	AA	1689.6	422.4	1689.6
SUBTOTALS				2,032.80	18,902.40
TOTAL					20,935.2
PAY TOTAL					20,935

PERMANENT AGGREGATE EDGE TREATMENT							
LOG MILE		ROUTE	LENGTH (MI)	WIDTH (FT)	DEPTH (IN)	QUANTITY (TONS)	REMARKS
FROM	TO						
0.002	2.599	AA	2.597	2	2	406.29	BEGINNING OF ROUTE TO END OF ROUTE
PAY TOTAL						406.3	

MODIFIED COLDMILLING (DEPTH TRANSITIONS)						
LOG MILE		ROUTE	LENGTH (FT)	AVERAGE WIDTH (FT)	QUANTITY (SY)	REMARKS
FROM	TO					
0.002	0.004	AA	10	120	133.33	FROM BEGINNING OF ROUTE
PAY TOTAL					133	

BITUMINOUS PAVEMENT MIXTURE PG58-28H SURFACE LEVELING							
LOG MILE	LOG MILE	ROUTE	LENGTH (MI)	WIDTH (FT)	TONS	TACK COAT (GAL)	REMARKS
0.002	2.599	AA	2.597	20	1675.93	2437.72	BEGINNING OF ROUTE TO END OF ROUTE
					389.55	--	ADDITIONAL 150 TONS/MILE FOR SURFACE IRREGULARITIES
TOTAL					2065.48	2437.72	
PAY TOTAL					2065.5	2438	

COLD MIX PATCHING		
ROUTE	REMOVAL OF DAMAGED PAVEMENT (S.Y.)	REPLACEMENT OF DAMAGED PAVEMENT (TONS)
AA	115.72	46.29
PAY TOTAL	115.7	46.3

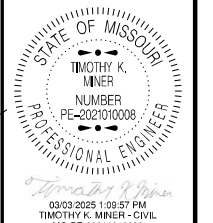

DATE PREPARED
3/3/2025

ROUTE AA STATE MO
DISTRICT NW SHEET NO. 3
COUNTY WORTH
JOB NO. JST0133
CONTRACT ID.

PROJECT NO.
BRIDGE NO.

DATE	DESCRIPTION
2/28/2025	SHEET DELETED.

MISSOURI HIGHWAYS AND TRANSPORTATION COMMISSION

105 WEST CAPITOL
JEFFERSON CITY, MO 65102
1-888-ASK-MODOT (1-888-275-6636)

1 SHEET DELETED
SUMMARY OF QUANTITIES
SHEET 1 OF 2

SIGN	SIZE	AREA	QTY	TOTAL	QTY	TOTAL	SIGN	DESCRIPTION
IN.	SQ. FT.	EACH	SQ. FT.	RELOC	RELOC	NUM.		
WARNING SIGNS								
WO1-1L	48X48	16.00						TURN (SYMBOL LEFT)
WO1-1R	48X48	16.00						TURN (SYMBOL RIGHT)
WO1-2L	48X48	16.00						CURVE (SYMBOL LEFT)
WO1-2R	48X48	16.00						CURVE (SYMBOL RIGHT)
WO1-3L	48X48	16.00						REVERSE TURN (SYMBOL LEFT)
WO1-3R	48X48	16.00						REVERSE TURN (SYMBOL RIGHT)
WO1-4L	48X48	16.00						REVERSE CURVE (SYMBOL LEFT)
WO1-4R	48X48	16.00						REVERSE CURVE (SYMBOL RIGHT)
WO1-4bL	48X48	16.00						DOUBLE ARROW REVERSE CURVE (SYMBOL LEFT)
WO1-4bR	48X48	16.00						DOUBLE ARROW REVERSE CURVE (SYMBOL RIGHT)
WO1-4cL	48X48	16.00						TRIPLE ARROW REVERSE CURVE (SYMBOL LEFT)
WO1-4cR	48X48	16.00						TRIPLE ARROW REVERSE CURVE (SYMBOL RIGHT)
WO1-6	60X30	12.50						HORIZONTAL ARROW (SYMBOL)
WO1-6a	72X36	18.00						HORIZ. ARROW (SYMBOL ON PERMANENT BARRICADE)
WO1-7	60X30	12.50						DOUBLE HEAD HORIZONTAL ARROW (SYMBOL)
WO1-7a	72X36	18.00						DOUBLE HEAD HORIZ. ARROW (SYMBOL ON PERM. BARR.)
WO1-8	18X24	3.00						CHEVRON (SYMBOL)
WO1-8a	30X36	7.50						CHEVRON (SYMBOL FOR DIVIDED HIGHWAYS)
WO3-1	48X48	16.00						STOP AHEAD (SYMBOL)
WO3-2	48X48	16.00						YIELD AHEAD (SYMBOL)
WO3-3	48X48	16.00						SIGNAL AHEAD (SYMBOL)
WO3-4	48X48	16.00						BE PREPARED TO STOP
WO3-5	48X48	16.00						SPEED LIMIT AHEAD
WO4-1L	48X48	16.00						MERGE (SYMBOL FROM LEFT)
WO4-1R	48X48	16.00						MERGE (SYMBOL FROM RIGHT)
WO4-1aL	48X48	16.00						MERGE (LEFT)
WO4-1aR	48X48	16.00						MERGE (RIGHT)
WO5-1	48X48	16.00						ROAD/BRIDGE/RAMP NARROWS
WO5-3	48X48	16.00						ONE LANE BRIDGE
WO5-5	48X48	16.00						NARROW LANES
WO6-1	48X48	16.00						DIVIDED HIGHWAY (SYMBOL)
WO6-2	48X48	16.00						DIVIDED HIGHWAY END (SYMBOL)
WO6-3	48X48	16.00						TWO WAY TRAFFIC (SYMBOL)
WO7-3a	30X24	5.00						NEXT XX MILES (PLAQUE)
WO8-1	48X48	16.00						BUMP
WO8-2	48X48	16.00						DIP
WO8-3	48X48	16.00						PAVEMENT ENDS
WO8-4	48X48	16.00						SOFT SHOULDER
WO8-5	48X48	16.00						SLIPPERY WHEN WET (SYMBOL)
WO8-6	48X48	16.00						TRUCK CROSSING
WO8-6c	48X48	16.00						TRUCK ENTRANCE
WO8-7	36X36	9.00						LOOSE GRAVEL
WO8-7a	36X36	9.00						FRESH OIL / LOOSE GRAVEL
WO8-9	48X48	16.00						LOW SHOULDER
WO8-11	48X48	16.00						UNEVEN LANES
WO8-12	48X48	16.00						NO CENTER LINE
WO8-15	48X48	16.00						GROOVED PAVEMENT
WO8-15P	30X24	5.00						MOTORCYCLE (PLAQUE)
WO8-17L	48X48	16.00						SHOULDER DROP-OFF (SYMBOL LEFT)
WO8-17R	48X48	16.00						SHOULDER DROP-OFF (SYMBOL RIGHT)
WO8-17P	30X24	5.00						SHOULDER DROP-OFF (PLAQUE)
W10-1	42RND.	9.62						RAILROAD CROSSING
WO12-1	24X24	4.00						DOUBLE DOWN ARROW (SYMBOL)
WO12-2	48X48	16.00						LOW CLEARANCE (SYMBOL)
WO12-2x	24X18	3.00						LOW CLEARANCE (PLAQUE)
WO12-2a	84X24	14.00						OVERHEAD LOW CLEARANCE (FEET AND INCHES)
WO12-4	120X60	50.00						LOW CLEARANCE XX FT XX IN XX MILES AHEAD
WO12-5	120X60	50.00						WIDTH RESTRICTION XX FT XX IN XX MILES AHEAD
WO13-1	30X30	6.25						ADVISORY SPEED (PLAQUE)
WO16-2	30X24	5.00						XXX FEET (PLAQUE)
WO16-3	30X24	5.00						X MILE (PLAQUE)
WO20-1	48X48	16.00						ROAD/BRIDGE/RAMP WORK AHEAD
WO20-2	48X48	16.00						DETOUR AHEAD
WO20-3	48X48	16.00	8	128.00		55/20		ROAD CLOSED AHEAD
WO20-4	48X48	16.00						ONE LANE ROAD AHEAD
WO20-5	48X48	16.00						RIGHT/CENTER/LEFT LANE CLOSED AHEAD
WO20-5a	48X48	16.00						2 RIGHT/CENTER/LEFT LANES CLOSED AHEAD
WO20-6a	48X48	16.00						RIGHT/CENTER/LEFT LANE CLOSED
WO20-7a	48X48	16.00						FLAGGER (SYMBOL)
WO21-2	36X36	9.00						FRESH OIL
WO21-5	48X48	16.00						SHOULDER WORK / SHOULDER WORK AHEAD
WO22-1	48X48	16.00						BLASTING ZONE AHEAD
WO22-2	42X36	10.50						TURN OFF 2-WAY RADIO AND PHONE
WO22-3	42X36	10.50						END BLASTING ZONE
GO22-1	21X15	2.19						WET PAINT (ARROW PIVOTS)

SIGN	SIZE	AREA	QTY	TOTAL	QTY	TOTAL	SIGN	DESCRIPTION
IN.	SQ. FT.	EACH	SQ. FT.	RELOC	RELOC	NUM.		
GUIDE SIGNS								
E05-1	36X48	12.00						GORE EXIT
E05-2	48X36	12.00						EXIT OPEN
E05-2a	48X36	12.00						EXIT CLOSED
GO20-1	60X24	10.00						ROAD WORK NEXT XX MILES
GO20-2	48X24	8.00						END ROAD WORK
GO20-4	36X18	4.50						PILOT CAR FOLLOW ME
GO20-4a	42X30	8.75						PILOT CAR IN USE WAIT & FOLLOW
GO20-4a	18X12	1.50						PILOT CAR IN USE WAIT & FOLLOW
GO20-5aP	36X24	6.00						WORK ZONE (PLAQUE)
MO4-8a	24X18	3.00						END DETOUR
MO4-9L	48X36	12.00						DETOUR (LEFT)
MO4-9R	48X36	12.00						DETOUR (RIGHT)
MO4-9P	48X12	4.00						STREET NAME (PLAQUE)
MO4-10L	48X18	6.00						DETOUR ARROW (LEFT)
MO4-10R	48X18	6.00						DETOUR ARROW (RIGHT)
REGULATORY SIGNS								
R1-1	48X48	13.25						STOP
R1-2	48TRI	6.93						YIELD
R1-2a	36X36	9.00						TO ONCOMING TRAFFIC (PLAQUE)
R1-3P	30X12	2.50						ALL WAY (PLAQUE)
R2-1	36X48	12.00						SPEED LIMIT XX
R3-1	48X48	16.00						NO RIGHT TURN (SYMBOL)
R3-2	48X48	16.00						NO LEFT TURN (SYMBOL)
R3-3	36X36	9.00						NO TURNS
R3-4	48X48	16.00						NO U-TURN (SYMBOL)
R3-7L	30X30	6.25						LEFT LANE MUST TURN LEFT
R3-7R	30X30	6.25						RIGHT LANE MUST TURN RIGHT
R4-1	36X48	12.00						DO NOT PASS
R4-2	36X48	12.00						PASS WITH CARE
R4-7a	36X48	12.00						KEEP RIGHT (HORIZONTAL ARROW)
R4-8a	36X48	12.00						KEEP LEFT (HORIZONTAL ARROW)
R5-1	30X30	6.25						DO NOT ENTER
R5-1a	36X24	6.00						WRONG WAY
R6-1L	54X18	6.75						ONE WAY ARROW (LEFT)
R6-1R	54X18	6.75						ONE WAY ARROW (RIGHT)
R6-2L	24X30	5.00						ONE WAY (LEFT)
R6-2R	24X30	5.00						ONE WAY (RIGHT)
R9-9	24X12	2.00						SIDEWALK CLOSED
R9-11L	24X18	3.00						SIDEWALK CLOSED AHEAD, (ARROW LEFT) CROSS HERE
R9-11R	24X18	3.00						SIDEWALK CLOSED AHEAD, (ARROW RIGHT) CROSS HERE
R10-8	24X36	6.00						STOP HERE ON RED (45° ARROW)
R11-2	48X30	10.00	4	40.00		56		ROAD CLOSED
R11-3a	60X30	12.50						ROAD CLOSED XX MILES AHEAD LOCAL TRAFFIC ONLY
R11-4	60X30	12.50						ROAD CLOSED TO THRU TRAFFIC
CONST-3A	60X48	20.00						FINE SIGN
CONST-3X	56X12	4.67						SPEEDING/PASSING (PLATE)
MISCELLANEOUS SIGNS								
CONST-5	48X36	12.00						POINT OF PRESENCE
CONST-5	96X48	32.00						POINT OF PRESENCE
CONST-8	48X36	12.00						WORK ZONE NO PHONE ZONE
				TOTAL				
616-10.05				168				
CONSTRUCTION SIGNS								
616-10.10				TOTAL				
RELOCATED SIGNS				0				

ITEM	TOTAL	DESCRIPTION
NUMBER	QTY	
6122008		IMPACT ATTENUATOR 40 MPH (SAND BARRELS)
6122009		IMPACT ATTENUATOR 45 MPH (SAND BARRELS)
6122010		IMPACT ATTENUATOR 50 MPH (SAND BARRELS)
6122012		IMPACT ATTENUATOR 55 MPH (SAND BARRELS)
6122014		IMPACT ATTENUATOR 60 MPH (SAND BARRELS)
6122017		IMPACT ATTENUATOR 65 MPH (SAND BARRELS)
6122019		IMPACT ATTENUATOR 70 MPH (SAND BARRELS)
6122020		REPLACEMENT SAND BARREL
6122030		IMPACT ATTENUATOR (RELOCATION)
6123001		TRUCK MOUNTED ATTENUATOR (TMA)
6161008		ADVANCED WARNING RAIL SYSTEM
6161012		BUOYS (BOATS KEEP OUT)
6161013		BUOYS (NO WAKE)
6161014		SPECIAL SIGN ASSEMBLY (BOATS KEEP OUT)
6161025		CHANNELIZER (TRIM LINE)
6161030	12	TYPE III MOVEABLE BARRICADE
6161033		DIRECTION INDICATOR BARRICADE
6161040		FLASHING ARROW PANEL
6161047		TYPE III OBJECT MARKER
6161055		SEQUENTIAL FLASHING WARNING LIGHT
6161070		TUBULAR MARKER
6161095		RADAR SPEED ADVISORY SYSTEM
6161096		CHANGEABLE MESSAGE SIGN, COMMISSION FURNISHED/RETAINED
6161098A		CHANGEABLE MESSAGE SIGN WITHOUT COMM. INTERFACE- CONTRACTOR FURNISHED/RETAINED
6161099		CHANGEABLE MESSAGE SIGN WITH COMM. INTERFACE- CONTRACTOR FURNISHED/RETAINED
6162000A		WORK ZONE TRAFFIC SIGNAL SYSTEM
6162002		TEMPORARY LONG-TERM RUMBLE STRIPS
6173600D		TEMPORARY TRAFFIC BARRIER CONTRACTOR FURNISHED/RETAINED
6173602B		TEMPORARY TRAFFIC BARRIER CONTRACTOR FURNISHED/COMMISSION RETAINED
6174000A		TEMP. TRAFFIC BARRIER HEIGHT TRANSITION
6175010A		RELOCATING TEMPORARY TRAFFIC BARRIER TEMPORARY TRAFFIC BARRIER
6176000B		COMMISSION FURNISHED/RETAINED TEMP. TRAFFIC BARRIER HEIGHT TRANSITION
6177000B		COMMISSION FURNISHED/RETAINED TEMPORARY RAISED PAVEMENT MARKER
6208064A		TEMPORARY TRAFFIC SIGNALS
9029400		TEMPORARY TRAFFIC SIGNALS AND LIGHTING

Mobilization
LUMP SUM = 1

616-99.01 - MISC. LUMP SUM
TEMPORARY TRAFFIC CONTROL
LUMP SUM = 1

1 SHEET DELETED

SUMMARY OF QUANTITIES
SHEET 2 OF 2

NOTE: ALL TEMPORARY TRAFFIC CONTROL ITEMS ARE INCLUDED IN PAY
ITEM 616-99.01 MISC. LUMP SUM TEMPORARY TRAFFIC CONTROL.
UNLESS OTHERWISE NOTED, QUANTITIES SHOWN ARE ESTIMATE
ONLY FOR TWO SEPARATE TWO MILE LONG LANE CLOSURE
SET UPS AND ARE SUBJECT TO CHANGE BASED ON FIELD CONDITIONS.

STATE OF MISSOURI
TIMOTHY K. MINER
NUMBER
PE-2021010008
PROFESSIONAL ENGINEER

03/03/2025 1:08:54 PM
TIMOTHY K. MINER - CIVIL
MO-PE-2021010008
DATE PREPARED
3/3/2025

ROUTE AA STATE MO
DISTRICT NW SHEET NO. 3
COUNTY WORTH
JOB NO. JST0133
CONTRACT



DATE PREPARED
3/3/2025

ROUTE AA STATE MO
DISTRICT NW SHEET NO. 4

COUNTY WORTH
JOB NO. JST0133
CONTRACT ID.

PROJECT NO.
BRIDGE NO.

DATE	DESCRIPTION
2/28/2025	SHEET DELETED.

MISSOURI HIGHWAYS AND TRANSPORTATION COMMISSION
105 WEST CAPITOL
JEFFERSON CITY, MO 65102
1-888-ASK-MODOT (1-888-275-6636)

MoDOT
SHEET DELETED
DEPTH TRANSITIONS
SPECIAL SHEET
1 OF 2

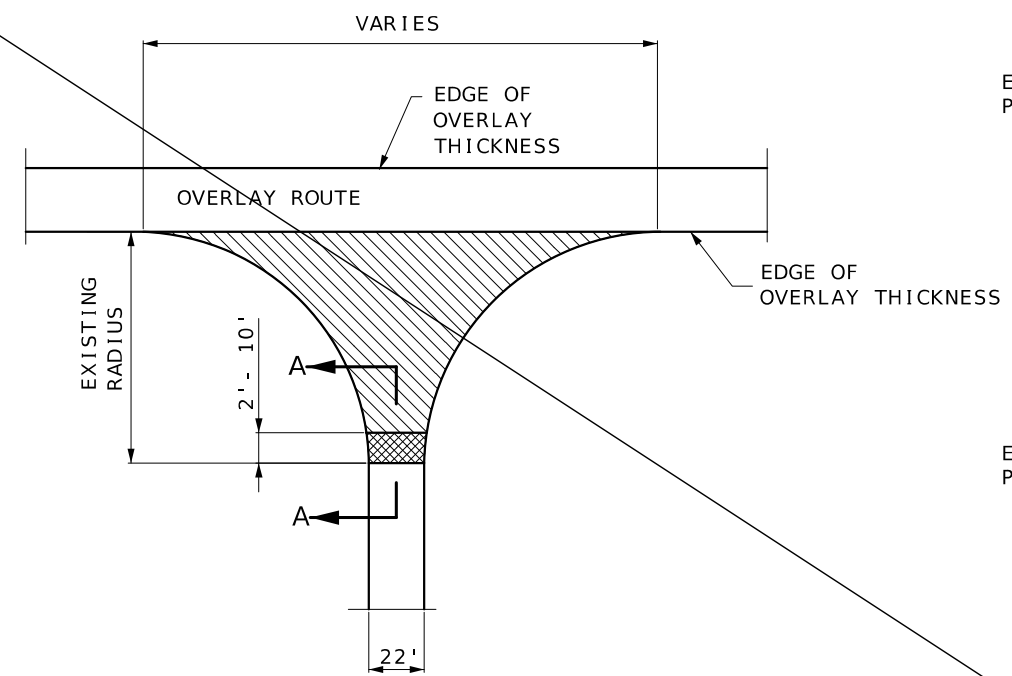

TYPICAL STATE ROUTE JUNCTION

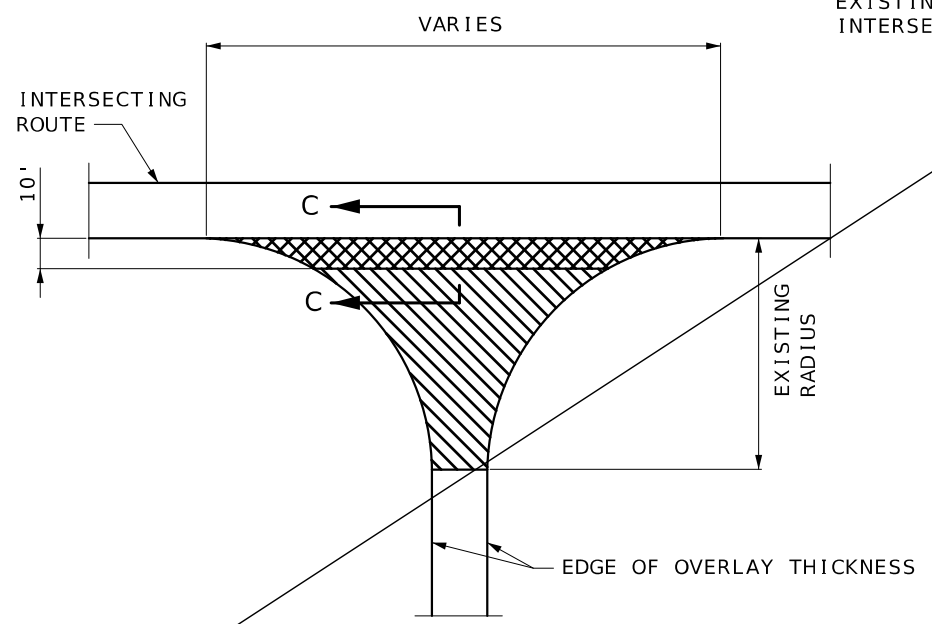

BEGINNING AND END OF PROJECT AT INTERSECTING ROUTE

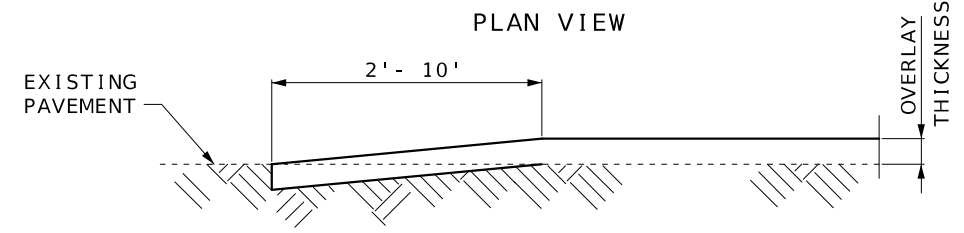

SECTION A-A
TYPICAL STATE ROUTE JUNCTION
(COLDMILLED TRANSITION)

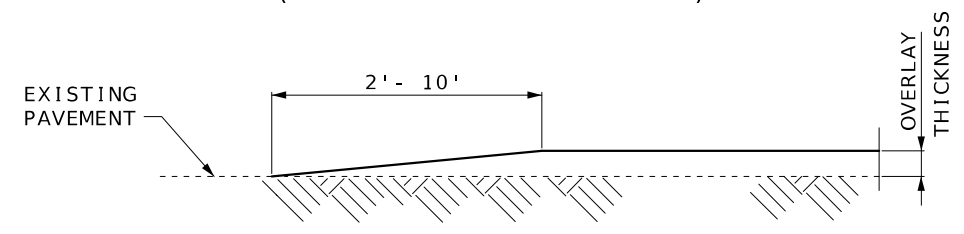

ALTERNATE SECTION A-A
TYPICAL STATE ROUTE JUNCTION
(TAPERED TRANSITION)

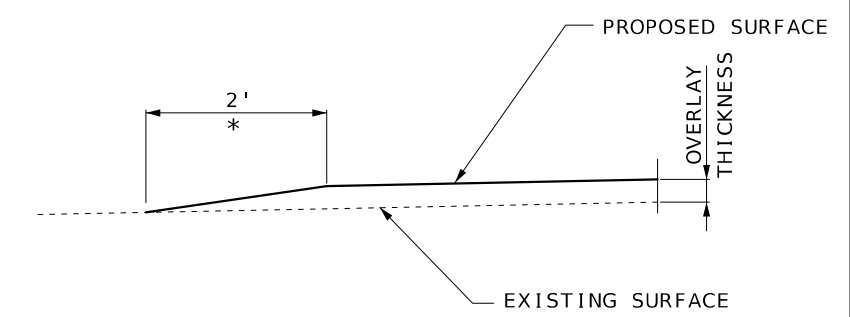
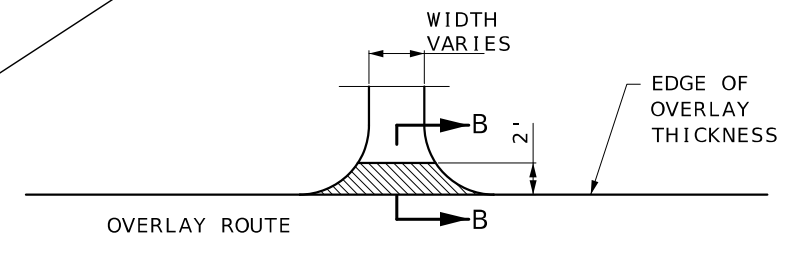

SECTION B-B
TYPICAL ENTRANCE
(FIELD, PRIVATE OR COUNTY ROAD)
* TAPER AT 1:1 FOR FIELD ENTRANCE

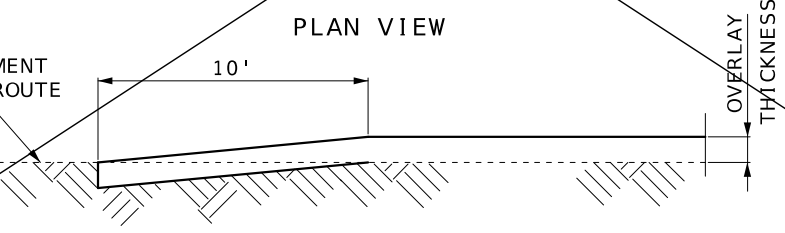

SECTION C-C
DEPTH TRANSITIONS
BEGINNING AND END OF PROJECT
AT INTERSECTING ROUTE

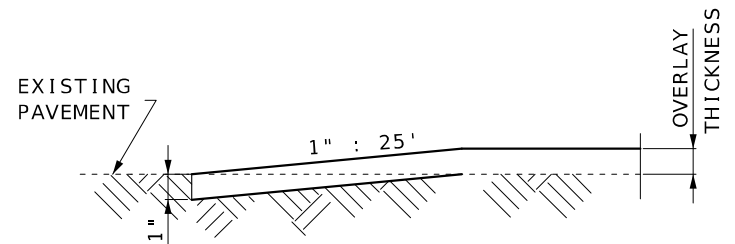

TRAVELWAY DEPTH TRANSITIONS
BEGINNING AND END OF PROJECT
NOT AT INTERSECTING ROUTE
AND AT EXCEPTIONS

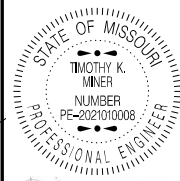

03/03/2025 1:07:59 PM
TIMOTHY K. MINER - CIVIL
MO-PE-2021010008

DATE PREPARED
3/3/2025

ROUTE AA STATE MO

DISTRICT NW SHEET NO. 5

COUNTY WORTH

JOB NO. JST0133

CONTRACT ID.

PROJECT NO.

BRIDGE NO.

DATE	DESCRIPTION
2/28/2025	SHEET DELETED

MISSOURI HIGHWAYS AND TRANSPORTATION COMMISSION



105 WEST CAPITOL
JEFFERSON CITY, MO 65102
1-888-ASK-MODOT (1-888-273-6636)

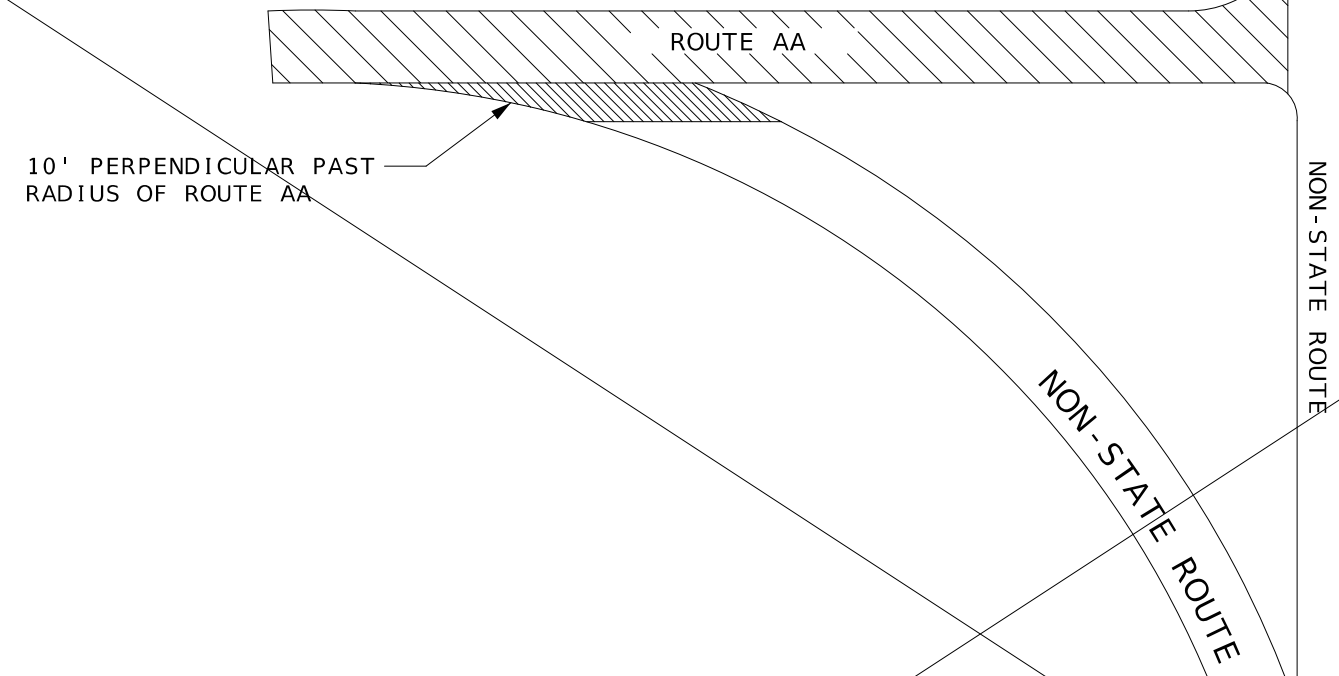

 GRAVEL (A) OR CRUSHED STONE (B)

 PAVEMENT RESURFACING

NOT TO SCALE

OVERLAY OF STATE ROUTES

 SHEET DELETED
OVERLAY PLAN
SPECIAL SHEET
2 OF 2



WD20-3
55

WD20-3
20

R11-2
56

TRAFFIC CONTROL LEGEND

- = SIGN
- = FLAGGER
- = TYPE III MOVEABLE BARRICADE
- = WORK AREA



03/03/2025 1:07:48 PM
TIMOTHY K. MINER - CIVIL
MO-PE-2021010008

DATE PREPARED
3/3/2025

ROUTE AA	STATE MO
DISTRICT NW	SHEET NO. 6

COUNTY
WORTH

JOB NO.
JST0133

CONTRACT ID.

PROJECT NO.

BRIDGE NO.

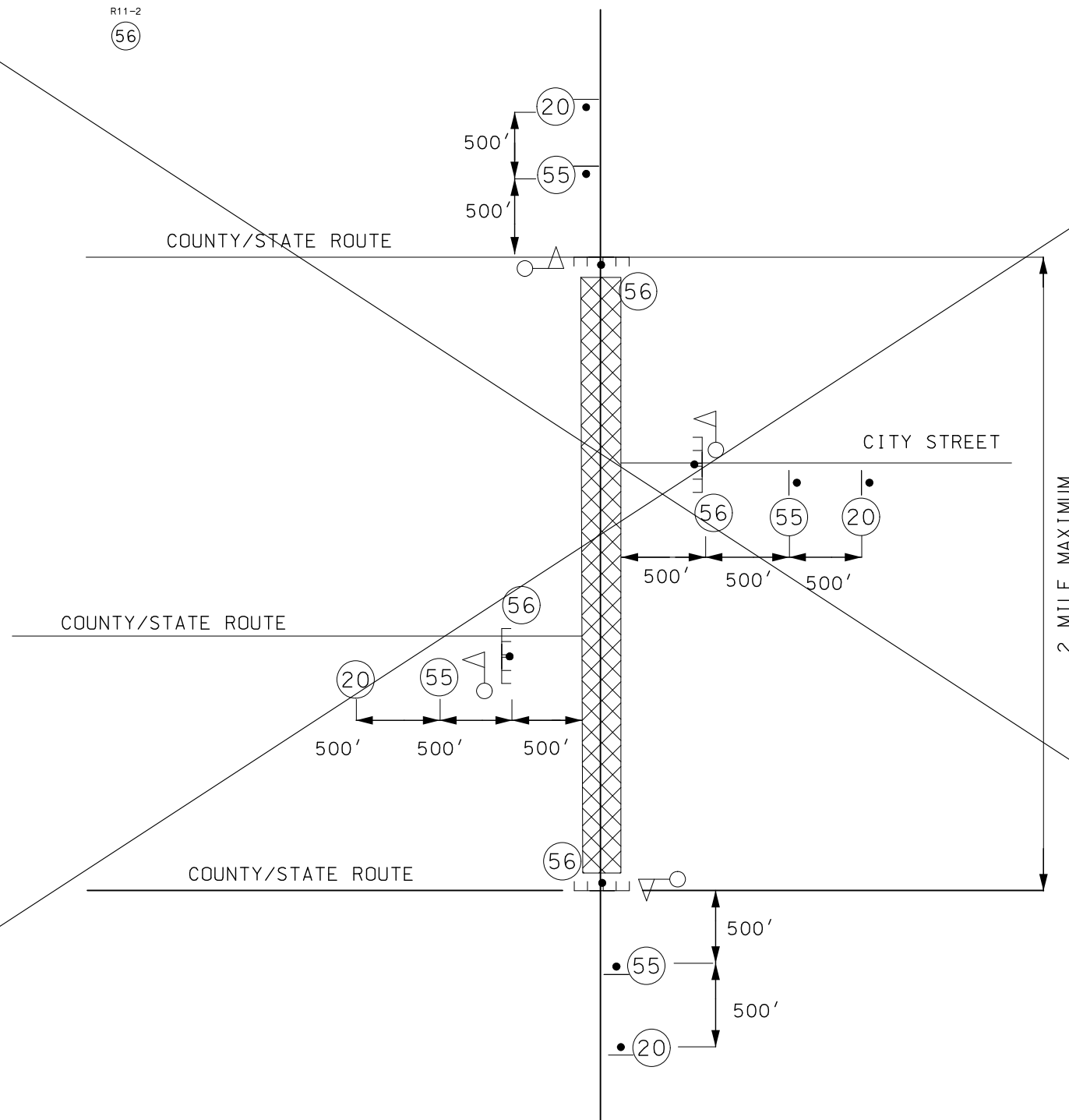

NOTE: THIS SHEET IS SUPPLEMENTAL TO STANDARD PLAN 616.20

NOT TO SCALE



SHEET DELETED
TRAFFIC CONTROL
SHEET 1 OF 1

DATE	DESCRIPTION
2/28/2025	SHEET DELETED.

MISSOURI HIGHWAYS AND TRANSPORTATION
COMMISSION



105 WEST CAPITOL
JEFFERSON CITY, MO 65102
1-888-ASK-MODOT (1-888-275-6636)

REV.

DESIGN DESIGNATION

A.A.D.T. - 2024 = 10
 A.A.D.T. - 2025 = 15
 D.H.V. = 7.5%
 T = 10%
 V = 55 M.P.H.
 D = 50%/50%

FUNCTIONAL CLASSIFICATION - MINOR COLLECTOR



KEY MAP
LOCATION OF HARRISON COUNTY

NO RIGHT OF WAY ACQUISITION

CONVENTIONAL SYMBOLS
(USED IN PLANS)

	EXISTING	NEW
BUILDINGS AND STRUCTURES		
GUARD RAIL		
GUARD CABLE		
CONCRETE RIGHT-OF-WAY MARKER		
STEEL RIGHT-OF-WAY MARKER		
LOCATION SURVEY MARKER		
UTILITIES		
FIBER OPTICS	-FO-	-FO-
OVERHEAD CABLE TV	-OTV-	-OTV-
UNDERGROUND CABLE TV	-UTV-	-UTV-
OVERHEAD TELEPHONE	-OT-	-OT-
UNDERGROUND TELEPHONE	-UT-	-UT-
OVERHEAD POWER	-OE-	-OE-
UNDERGROUND POWER	-UE-	-UE-
SANITARY SEWER	-S-	-S-
STORM SEWER	-SS-	-SS-
GAS	-G-	-G-
WATER	-W-	-W-
MANHOLE		
FIRE HYDRANT		
WATER VALVE		
WATER METER		
DROP INLET		
DITCH BLOCK		
GROUND MOUNTED SIGN		
LIGHT POLE		
H-FRAME POWER POLE		
TELEPHONE PEDESTAL		
FENCE		
CHAIN LINK		
WOVEN WIRE		
GATE POST		
BENCHMARK		

NOTE: DASHED OR OPEN SYMBOLS INDICATE EXISTING FEATURES

MISSOURI HIGHWAYS AND TRANSPORTATION COMMISSION PLANS FOR PROPOSED STATE HIGHWAY HARRISON COUNTY

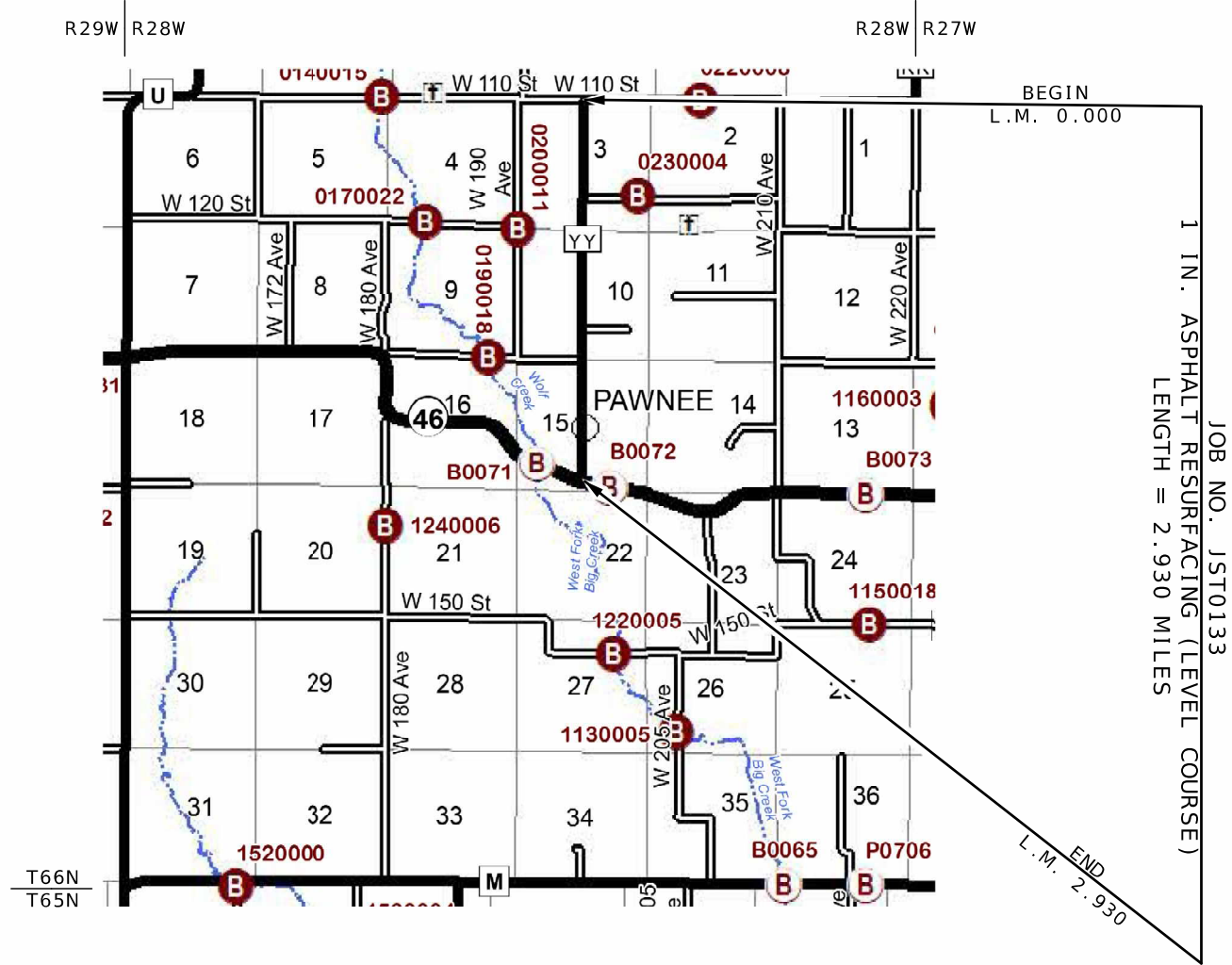

NOT TO SCALE

THE EXISTENCE AND APPROXIMATE LOCATION OF UTILITY FACILITIES KNOWN TO EXIST, AS SHOWN ON THE PLANS, ARE BASED ON THE BEST INFORMATION AVAILABLE TO THE COMMISSION AT THIS TIME. THIS INFORMATION IS PROVIDED BY THE COMMISSION "AS-IS" AND THE COMMISSION EXPRESSLY DISCLAIMS ANY REPRESENTATION OR WARRANTY AS TO THE COMPLETENESS, ACCURACY, OR SUITABILITY OF THE INFORMATION FOR ANY USE. RELIANCE UPON THIS INFORMATION IS DONE AT THE RISK AND PERIL OF THE USER, AND THE COMMISSION SHALL NOT BE LIABLE FOR ANY DAMAGES THAT MAY ARISE FROM ANY ERROR IN THE INFORMATION. IT IS, THEREFORE, THE RESPONSIBILITY OF THE CONTRACTOR TO VERIFY THE EXISTENCE, LOCATION AND STATUS OF ANY FACILITY. SUCH VERIFICATION INCLUDES DIRECT CONTACT WITH THE LISTED UTILITIES.

1 SHEET ADDED

INDEX OF SHEETS

DESCRIPTION	SHEET NUMBER
TITLE SHEET	1
TYPICAL SECTIONS (TS) (1 SHEET)----	2
QUANTITIES (QU) (2 SHEETS)-----	3
SPECIAL SHEET (SS)-----	4
TRAFFIC CONTROL SHEET (TC)-----	5



DATE PREPARED
3/3/2025
 ROUTE STATE
YY MO
 DISTRICT SHEET NO.
NW 1A
 COUNTY
HARRISON
 JOB NO.
JST0133
 CONTRACT ID.
 PROJECT NO.
 BRIDGE NO.

DATE	DESCRIPTION
2/28/2025	SHEET ADDED

LENGTH OF PROJECT

BEGINNING OF PROJECT	L.M. 0.000
END OF PROJECT	L.M. 2.930
APPARENT LENGTH	2.930 MILES

TOTAL CORRECTIONS	0 MILES
NET LENGTH OF PROJECT	2.930 MILES
STATE LENGTH	2.930 MILES
FOR INFORMATION ONLY ESTIMATED DISTURBED ACRES	0 ACRES

MISSOURI HIGHWAYS AND TRANSPORTATION COMMISSION

105 WEST CAPITOL
JEFFERSON CITY, MO 65102
1-888-ASK-MODOT (1-888-275-6636)

*NOTE:
PAVING WILL BE DONE AT FULL WIDTH
OF THE ROADWAY TO ELIMINATE CENTERLINE
JOINT.

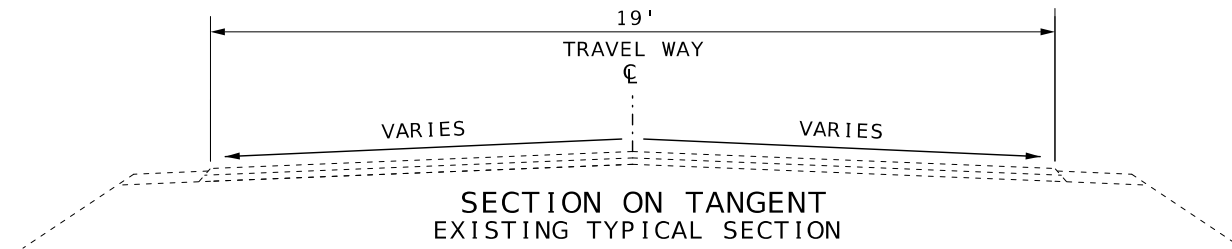

RTE. YY (HARRISON) LOG MILE 0.000 TO LOG MILE 2.930

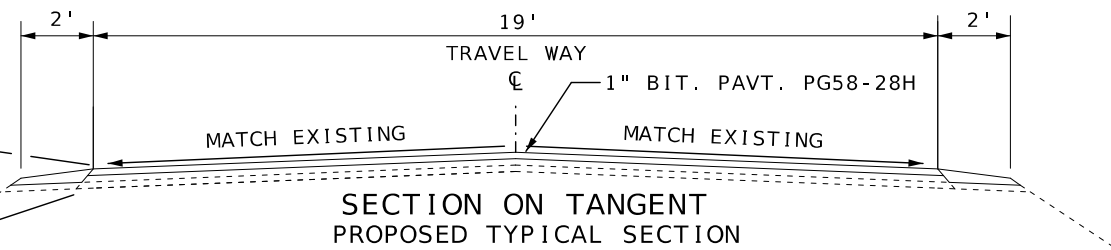
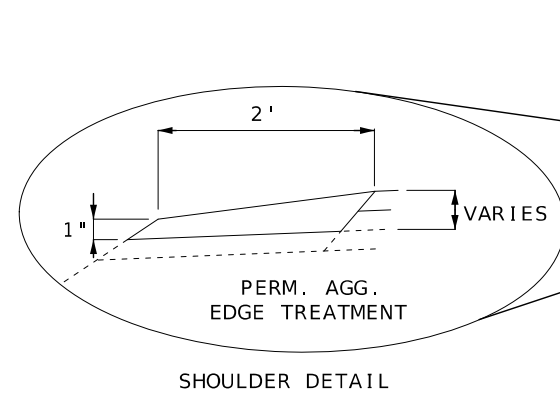

RTE. YY (HARRISON) LOG MILE 0.000 TO LOG MILE 2.930

ESTIMATE FACTORS *

DESCRIPTION	FACTOR
BITUMINOUS PAVEMENT MIXTURE PG58-28H SURFACE LEVELING	1.98 TONS/CY
TACK COAT	EXISTING PAVEMENT 0.08 GAL/SY MILLED SURFACE 0.10 GAL/SY
GRAVEL A OR CRUSHED STONE B	1.6 TONS/CY
PERMANENT AGGREGATE EDGE TREATMENT	1.6 TONS/CY

* FOR INFORMATION PURPOSES ONLY

NOT TO SCALE

1 SHEET ADDED
TYPICAL SECTIONS
SHEET 1A OF 1A



DATE PREPARED
3/3/2025

ROUTE STATE
YY MO

DISTRICT SHEET NO.
NW 2A

COUNTY
HARRISON

JOB NO.
JST0133

CONTRACT ID.

PROJECT NO.

BRIDGE NO.

DATE	DESCRIPTION
2/28/2025	SHEET ADDED.

MISSOURI HIGHWAYS AND TRANSPORTATION COMMISSION

105 WEST CAPITOL
JEFFERSON CITY, MO 65102
1-888-ASK-MODOT (1-888-275-6636)

REV.

STANDARD WATERBORNE PAVEMENT MARKING PAINT, TYPE P BEADS							
LOG MILE		ROUTE	COUNTY	LENGTH (FT)	4" INT. YELLOW (FT)	4" SOLID YELLOW (FT)	REMARKS
FROM	TO						
0	0.211	YY	HARRISON	1114.08		2228.16	NO PASSING
0.211	0.331	YY	HARRISON	633.6	158.4	633.6	NO PASSING SOUTH, PASSING NORTH
0.331	0.491	YY	HARRISON	844.8		1689.6	NO PASSING
0.491	0.571	YY	HARRISON	422.4	105.6	422.4	PASSING SOUTH, NO PASSIN NORTH
0.571	0.611	YY	HARRISON	211.2		422.4	NO PASSING
0.611	0.731	YY	HARRISON	633.6	158.4	633.6	NO PASSING SOUTH, PASSING NORTH
0.731	0.851	YY	HARRISON	633.6	158.4	633.6	PASSING SOUTH, NO PASSIN NORTH
0.851	0.871	YY	HARRISON	105.6		211.2	NO PASSING
0.871	0.991	YY	HARRISON	633.6	158.4	633.6	NO PASSING SOUTH, PASSING NORTH
0.991	1.111	YY	HARRISON	633.6		1267.2	NO PASSING
1.111	1.191	YY	HARRISON	422.4	105.6	422.4	PASSING SOUTH, NO PASSIN NORTH
1.191	1.211	YY	HARRISON	105.6	26.4		PASSING BOTH DIRECTIONS
1.211	1.33	YY	HARRISON	628.32	157.08	628.32	NO PASSING SOUTH, PASSING NORTH
1.33	1.749	YY	HARRISON	2212.32		4424.64	NO PASSING
1.749	1.889	YY	HARRISON	739.2	184.8	739.2	PASSING SOUTH, NO PASSIN NORTH
1.889	1.909	YY	HARRISON	105.6		211.2	NO PASSING
1.909	2.029	YY	HARRISON	633.6	158.4	633.6	NO PASSING SOUTH, PASSING NORTH
2.029	2.129	YY	HARRISON	528	132	528	PASSING SOUTH, NO PASSIN NORTH
2.129	2.269	YY	HARRISON	739.2		1478.4	NO PASSING
2.269	2.369	YY	HARRISON	528	132	528	PASSING SOUTH, NO PASSIN NORTH
2.369	2.409	YY	HARRISON	211.2		422.4	NO PASSING
2.409	2.509	YY	HARRISON	528	132	528	NO PASSING SOUTH, PASSING NORTH
2.509	2.549	YY	HARRISON	211.2		422.4	NO PASSING
2.549	2.709	YY	HARRISON	844.8	211.2	844.8	PASSING SOUTH, NO PASSIN NORTH
2.709	2.849	YY	HARRISON	739.2	184.8		PASSING BOTH DIRECTIONS
2.849	2.89	YY	HARRISON	216.48	54.12	216.48	NO PASSING SOUTH, PASSING NORTH
2.89	2.93	YY	HARRISON	211.2		422.4	NO PASSING
				TOTALS	2,217.60	21,225.60	
					PAY TOTAL	23,443	

PERMANENT AGGREGATE EDGE TREATMENT							
LOG MILE		ROUTE	LENGTH (MI)	WIDTH (FT)	DEPTH (IN)	QUANTITY (TONS)	REMARKS
FROM	TO						
0.000	2.930	YY	2.930	2	2	458.38	BEGINNING OF ROUTE TO END OF ROUTE
			0.002	20	2	25.03	GRAVEL FOR ENTRANCES
				PAY TOTAL		483.4	

MODIFIED COLDMILLING (DEPTH TRANSITIONS)						
LOG MILE		ROUTE	LENGTH (FT)	AVERAGE WIDTH (FT)	QUANTITY (SY)	REMARKS
FROM	TO					
0.000	0.002	YY	10	120	133.33	BEGINNING OF ROUTE
				PAY TOTAL	133	

BITUMINOUS PAVEMENT MIXTURE PG58-28H SURFACE LEVELING							
LOG MILE	LOG MILE	ROUTE	LENGTH (MI)	WIDTH (FT)	(TONS)	TACK COAT (GAL)	REMARKS
0.000	2.930	YY	2.930	19	1796.29	2612.78	BEGINNING OF ROUTE TO END OF ROUTE
					439.50	--	ADDITIONAL 150 TONS/MILE FOR SURFACE IRREGULARITIES
					TOTAL	2235.79	2612.78
					PAY TOTAL	2235.8	2613

COLD MIX PATCHING			
ROUTE	REMOVAL OF DAMAGED PAVEMENT (S.Y.)	REPLACEMENT OF DAMAGED PAVEMENT (TONS)	
YY	114.31		45.72
PAY TOTAL	114.3		45.7

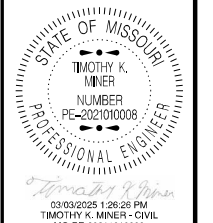

DATE PREPARED
3/3/2025

ROUTE YY STATE MO

DISTRICT NW SHEET NO. 3A

COUNTY
HARRISON

JOB NO.
JST0133

CONTRACT ID.

PROJECT NO.

BRIDGE NO.

DATE	DESCRIPTION
2/28/2025	SHEET ADDED.

MISSOURI HIGHWAYS AND TRANSPORTATION COMMISSION

105 WEST CAPITOL
JEFFERSON CITY, MO 65102
1-888-ASK-MODOT (1-888-275-6636)

1 SHEET ADDED
SUMMARY OF QUANTITIES
SHEET 1A OF 2A

WARNING SIGNS										GUIDE SIGNS										REGULATORY SIGNS										MISCELLANEOUS SIGNS									
SIGN	SIZE IN.	AREA SQ. FT.	QTY EACH	TOTAL AREA SQ. FT.	QTY RELOC EACH	TOTAL RELOC SQ. FT.	SIGN NUM.	DESCRIPTION		SIGN	SIZE IN.	AREA SQ. FT.	QTY EACH	TOTAL AREA SQ. FT.	QTY RELOC EACH	TOTAL RELOC SQ. FT.	SIGN NUM.	DESCRIPTION		SIGN	SIZE IN.	AREA SQ. FT.	QTY EACH	TOTAL AREA SQ. FT.	QTY RELOC EACH	TOTAL RELOC SQ. FT.	SIGN NUM.	DESCRIPTION		SIGN	SIZE IN.	AREA SQ. FT.	QTY EACH	TOTAL AREA SQ. FT.	QTY RELOC EACH	TOTAL RELOC SQ. FT.	SIGN NUM.	DESCRIPTION	
WO1-1L	48X48	16.00						TURN (SYMBOL LEFT)		E05-1	36X48	12.00						GORE EXIT		R1-1	48X48	13.25						STOP		CONST-5	48X36	12.00						POINT OF PRESENCE	
WO1-1R	48X48	16.00						TURN (SYMBOL RIGHT)		E05-2	48X36	12.00						EXIT OPEN		R1-2	48TRI	6.93						YIELD		CONST-5	96X48	32.00						POINT OF PRESENCE	
WO1-2L	48X48	16.00						CURVE (SYMBOL LEFT)		E05-2a	48X36	12.00						EXIT CLOSED		R1-2a	36X36	9.00						TO ONCOMING TRAFFIC (PLAQUE)		CONST-8	48X36	12.00						WORK ZONE NO PHONE ZONE	
WO1-2R	48X48	16.00						CURVE (SYMBOL RIGHT)		GO20-1	60X24	10.00						ROAD WORK NEXT XX MILES		R1-3P	30X12	2.50						ALL WAY (PLAQUE)											
WO1-3L	48X48	16.00						REVERSE TURN (SYMBOL LEFT)		GO20-2	48X24	8.00						END ROAD WORK		R2-1	36X48	12.00						SPEED LIMIT XX											
WO1-3R	48X48	16.00						REVERSE TURN (SYMBOL RIGHT)		GO20-4	36X18	4.50						PILOT CAR FOLLOW ME		R3-1	48X48	16.00						NO RIGHT TURN (SYMBOL)											
WO1-4L	48X48	16.00						REVERSE CURVE (SYMBOL LEFT)		GO20-4a	42X30	8.75						PILOT CAR IN USE WAIT & FOLLOW		R3-2	48X48	16.00						NO LEFT TURN (SYMBOL)											
WO1-4R	48X48	16.00						REVERSE CURVE (SYMBOL RIGHT)		GO20-4a	18X12	1.50						PILOT CAR IN USE WAIT & FOLLOW		R3-3	36X36	9.00						NO TURNS											
WO1-4bL	48X48	16.00						DOUBLE ARROW REVERSE CURVE (SYMBOL LEFT)		GO20-5aP	36X24	6.00						WORK ZONE (PLAQUE)		R3-4	48X48	16.00						NO U-TURN (SYMBOL)											
WO1-4bR	48X48	16.00						DOUBLE ARROW REVERSE CURVE (SYMBOL RIGHT)		MO4-8a	24X18	3.00						END DETOUR		R3-7L	30X30	6.25						LEFT LANE MUST TURN LEFT											
WO1-4cL	48X48	16.00						TRIPLE ARROW REVERSE CURVE (SYMBOL LEFT)		MO4-9L	48X36	12.00						DETOUR (LEFT)		R3-7R	30X30	6.25						RIGHT LANE MUST TURN RIGHT											
WO1-4cR	48X48	16.00						TRIPLE ARROW REVERSE CURVE (SYMBOL RIGHT)		MO4-9R	48X36	12.00						DETOUR (RIGHT)		R4-1	36X48	12.00						DO NOT PASS											
WO1-6	60X30	12.50						HORIZONTAL ARROW (SYMBOL)		MO4-9P	48X12	4.00						STREET NAME (PLAQUE)		R4-2	36X48	12.00						PASS WITH CARE											
WO1-6a	72X36	18.00						HORIZ. ARROW (SYMBOL ON PERMANENT BARRICADE)		MO4-10L	48X18	6.00						DETOUR ARROW (LEFT)		R4-7a	36X48	12.00						KEEP RIGHT (HORIZONTAL ARROW)											
WO1-7	60X30	12.50						DOUBLE HEAD HORIZONTAL ARROW (SYMBOL)		MO4-10R	48X18	6.00						DETOUR ARROW (RIGHT)		R4-8a	36X48	12.00						KEEP LEFT (HORIZONTAL ARROW)											
WO1-7a	72X36	18.00						DOUBLE HEAD HORIZ. ARROW (SYMBOL ON PERM. BARR.)												R5-1	30X30	6.25						DO NOT ENTER											
WO1-8	18X24	3.00						CHEVRON (SYMBOL)												R5-1a	36X24	6.00						WRONG WAY											
WO1-8a	30X36	7.50						CHEVRON (SYMBOL FOR DIVIDED HIGHWAYS)												R6-1L	54X18	6.75						ONE WAY ARROW (LEFT)											
WO3-1	48X48	16.00						STOP AHEAD (SYMBOL)												R6-1R	54X18	6.75						ONE WAY ARROW (RIGHT)											
WO3-2	48X48	16.00						YIELD AHEAD (SYMBOL)												R6-2L	24X30	5.00						ONE WAY (LEFT)											
WO3-3	48X48	16.00						SIGNAL AHEAD (SYMBOL)												R6-2R	24X30	5.00						ONE WAY (RIGHT)											
WO3-4	48X48	16.00						BE PREPARED TO STOP												R9-9	24X12	2.00						SIDEWALK CLOSED											
WO3-5	48X48	16.00						SPEED LIMIT AHEAD												R9-11L	24X18	3.00						SIDEWALK CLOSED AHEAD, (ARROW LEFT) CROSS HERE											
WO4-1L	48X48	16.00						MERGE (SYMBOL FROM LEFT)												R9-11R	24X18	3.00						SIDEWALK CLOSED AHEAD, (ARROW RIGHT) CROSS HERE											
WO4-1R	48X48	16.00						MERGE (SYMBOL FROM RIGHT)												R10-6	24X36	6.00						STOP HERE ON RED (45° ARROW)											
WO4-1aL	48X48	16.00						MERGE (LEFT)												R11-2	48X30	10.00	4	40.00			56	ROAD CLOSED											
WO4-1aR	48X48	16.00						MERGE (RIGHT)												R11-3a	60X30	12.50						ROAD CLOSED XX MILES AHEAD LOCAL TRAFFIC ONLY											
WO5-1	48X48	16.00						ROAD/BRIDGE/RAMP NARROWS												R11-4	60X30	12.50						ROAD CLOSED TO THRU TRAFFIC											
WO5-3	48X48	16.00						ONE LANE BRIDGE												CONST-3A	60X48	20.00						FINE SIGN											
WO5-5	48X48	16.00						NARROW LANES												CONST-3X	56X12	4.67						SPEEDING/PASSING (PLATE)											
WO6-1	48X48	16.00						DIVIDED HIGHWAY (SYMBOL)																															
WO6-2	48X48	16.00						DIVIDED HIGHWAY END (SYMBOL)																															
WO6-3	48X48	16.00						TWO WAY TRAFFIC (SYMBOL)																															
WO7-3a	30X24	5.00						NEXT XX MILES (PLAQUE)																															
WO8-1	48X48	16.00						BUMP																															
WO8-2	48X48	16.00						DIP																															
WO8-3	48X48	16.00						PAVEMENT ENDS																															
WO8-4	48X48	16.00						SOFT SHOULDER																															
WO8-5	48X48	16.00						SLIPPERY WHEN WET (SYMBOL)																															
WO8-6	48X48	16.00						TRUCK CROSSING																															
WO8-6c	48X48	16.00						TRUCK ENTRANCE																															
WO8-7	36X36	9.00						LOOSE GRAVEL																															
WO8-7a	36X36	9.00						FRESH OIL / LOOSE GRAVEL																															
WO8-9	48X48	16.00						LOW SHOULDER																															
WO8-11	48X48	16.00						UNEVEN LANES																															
WO8-12	48X48	16.00						NO CENTER LINE																															
WO8-15	48X48	16.00						GROOVED PAVEMENT																															
WO8-15P	30X24	5.00						MOTORCYCLE (PLAQUE)																															
WO8-17L	48X48	16.00						SHOULDER DROP-OFF (SYMBOL LEFT)																															
WO8-17R	48X48	16.00						SHOULDER DROP-OFF (SYMBOL RIGHT)																															
WO8-17P	30X24	5.00						SHOULDER DROP-OFF (PLAQUE)																															
W10-1	42RND.	9.62						RAILROAD CROSSING																															
WO12-1	24X24	4.00						DOUBLE DOWN ARROW (SYMBOL)																															
WO12-2	48X48	16.00						LOW CLEARANCE (SYMBOL)																															
WO12-2x	24X18	3.00						LOW CLEARANCE (PLAQUE)																															
WO12-2a	84X24	14.00						OVERHEAD LOW CLEARANCE (FEET																															

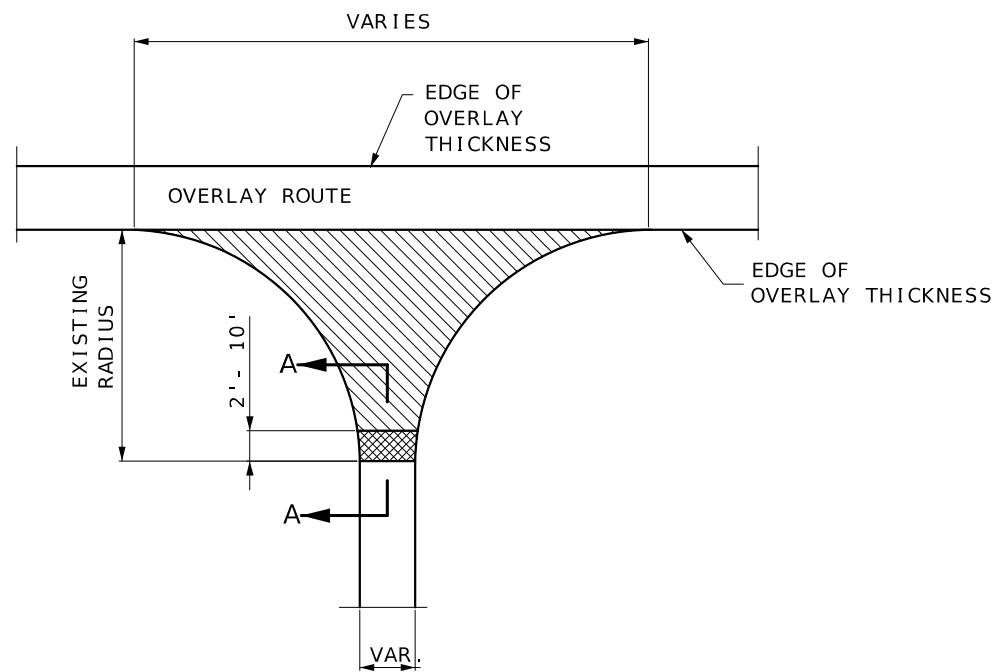

TYPICAL STATE ROUTE JUNCTION

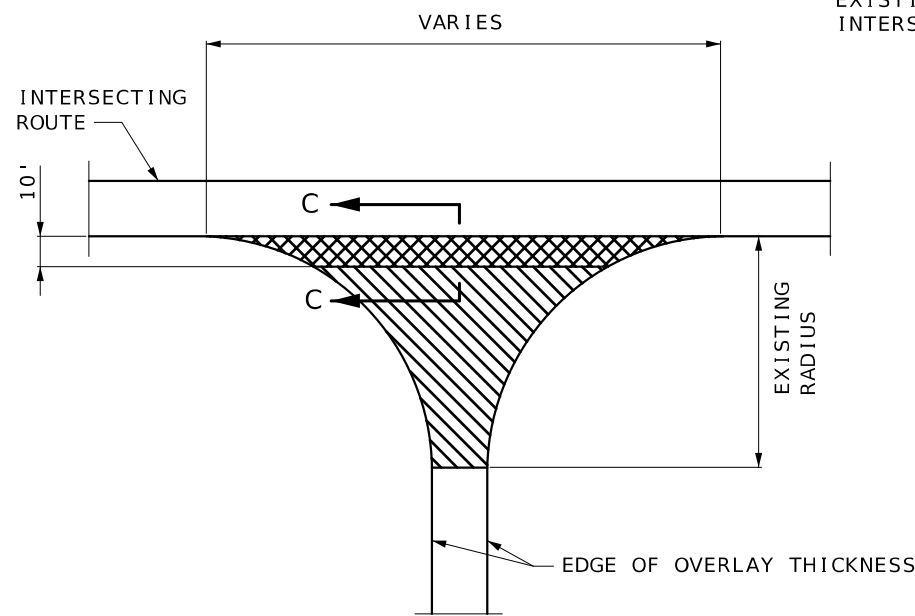

BEGINNING AND END OF PROJECT AT INTERSECTING ROUTE

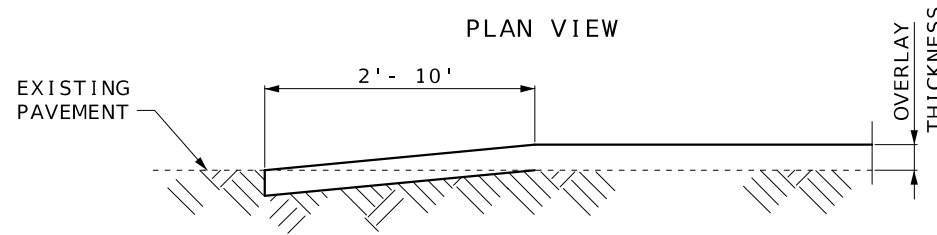

SECTION A-A
TYPICAL STATE ROUTE JUNCTION
(COLDMILLED TRANSITION)

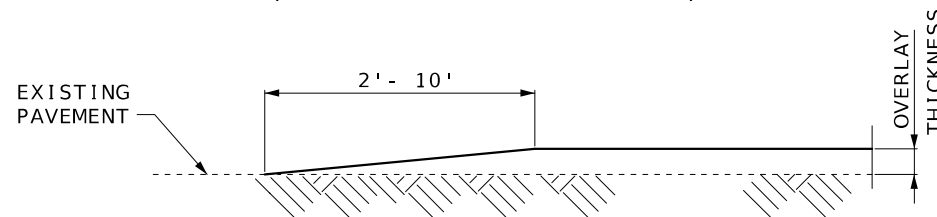

ALTERNATE SECTION A-A
TYPICAL STATE ROUTE JUNCTION
(TAPERED TRANSITION)

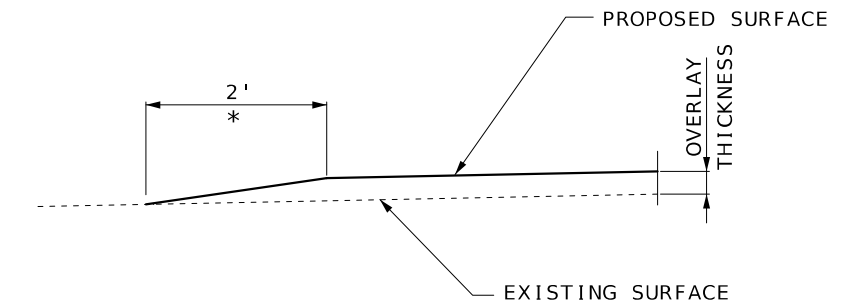
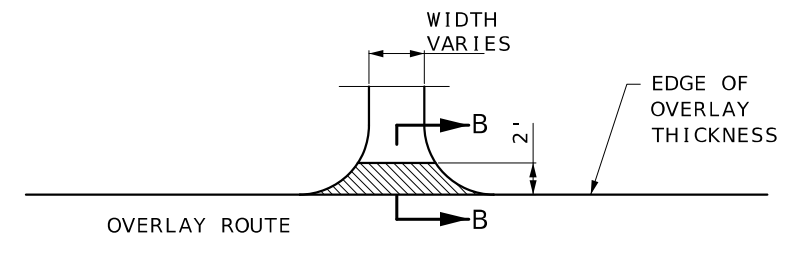

SECTION B-B
TYPICAL ENTRANCE
(FIELD, PRIVATE OR COUNTY ROAD)
* TAPER AT 1:1 FOR FIELD ENTRANCE

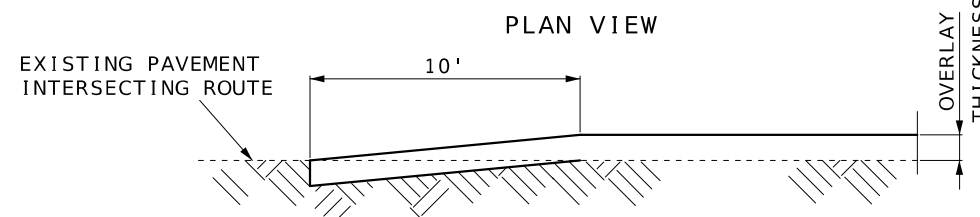

SECTION C-C
DEPTH TRANSITIONS
BEGINNING AND END OF PROJECT
AT INTERSECTING ROUTE

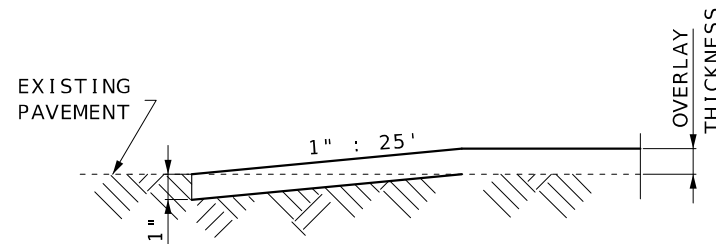

TRAVELWAY DEPTH TRANSITIONS
BEGINNING AND END OF PROJECT
NOT AT INTERSECTING ROUTE
AND AT EXCEPTIONS

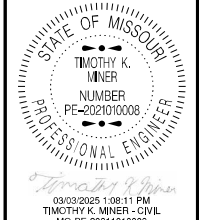

DATE PREPARED

3/3/2025

ROUTE STATE

YY MO

DISTRICT SHEET NO.

NW 4A

COUNTY

HARRISON

JOB NO.

IST0133

CONTRACT ID.

PROJECT NO.

BRIDGE NO.

DESCRIPTION	DATE
SHEET ADDED.	2/28/2025

MISSOURI HIGHWAYS AND TRANSPORTATION COMMISSION

MoDOT

105 WEST CAPITOL
JEFFERSON CITY, MO 65102
1-888-ASK-MODOT (1-888-275-6636)

1 SHEET ADDED

DEPTH TRANSITIONS
SPECIAL SHEET
1A OF 1A



TRAFFIC CONTROL LEGEND

- = SIGN
- = FLAGGER
- = TYPE III MOVEABLE BARRICADE
- = WORK AREA

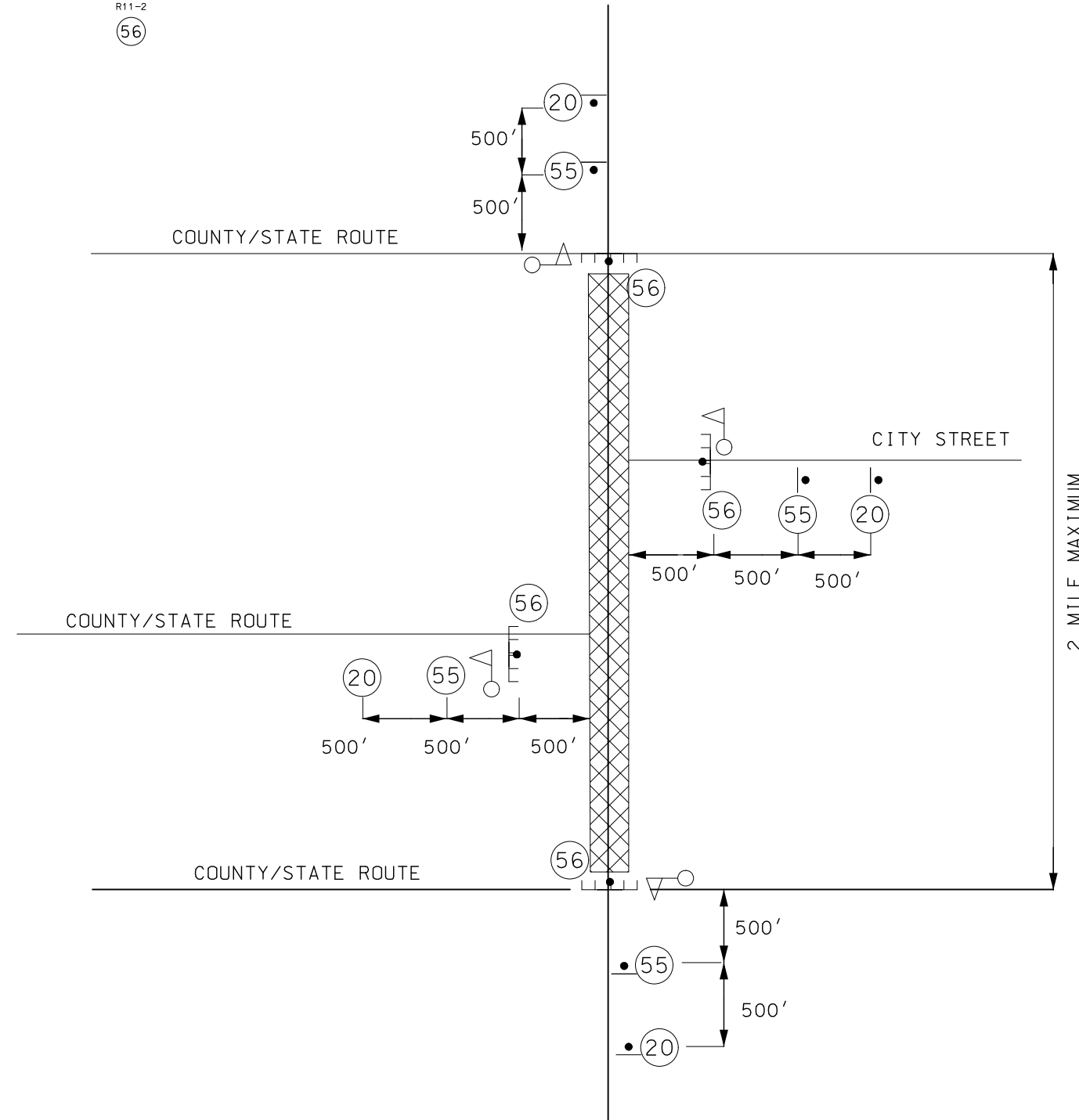

NOTE: THIS SHEET IS SUPPLEMENTAL TO STANDARD PLAN 616.20

NOT TO SCALE

SHEET ADDED

TRAFFIC CONTROL
SHEET 1A OF 1A



DATE PREPARED
3/3/2025
ROUTE YY STATE MO
DISTRICT NW SHEET NO. 5A
COUNTY HARRISON
JOB NO. JST0133
CONTRACT ID.
PROJECT NO.
BRIDGE NO.

DATE	DESCRIPTION
2/28/2025	SHEET ADDED

MISSOURI HIGHWAYS AND TRANSPORTATION COMMISSION

 105 WEST CAPITOL
 JEFFERSON CITY, MO 65102
 1-888-ASK-MODOT (1-888-275-6636)

REV.