

Job No.: J9P3678

Route: 164

County: Dunklin

JOB SPECIAL PROVISIONS TABLE OF CONTENTS (ROADWAY)

(Job Special Provisions shall prevail over General Special Provisions whenever in conflict therewith.)

A.	General - Federal JSP-09-02K	1
B.	Contract Liquidated Damages JSP-13-01D	1
C.	Work Zone Traffic Management JSP-02-06N	2
D.	Emergency Provisions and Incident Management JSP-90-11A	4
E.	Project Contact for Contractor/Bidder Questions JSP-96-05	5
F.	Supplemental Revisions JSP-18-01FF	5
G.	Utilities JSP-93-26F	12
H.	Restrictions for Migratory Birds NJSP-16-06A	13
I.	Liquidated Damages for Winter Months JSP-04-17A	15
J.	Contractor Quality Control NJSP-15-42	15
K.	Modified Linear Grading Class 2	17
L.	Damage to Existing Roadways and Entrances	18
M.	Temporary Stream Crossings and Workpads	18
N.	DBE Prompt Payment Reporting JSP-24-05B	19
O.	Optional Pavements JSP 06-06H	20

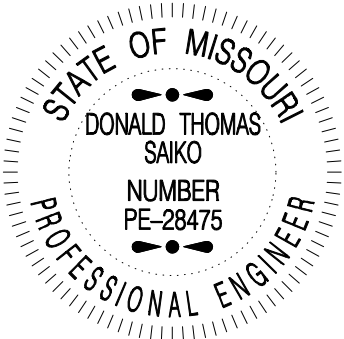
 <p>THIS SHEET HAS BEEN SIGNED, SEALED AND DATED ELECTRONICALLY.</p>	MISSOURI HIGHWAYS AND TRANSPORTATION COMMISSION 105 W. CAPITOL AVE. JEFFERSON CITY, MO 65102 Phone 1-888-275-6636
	GARVER 7509 NW Tiffany Springs Parkway, STE 200
	Certificate of Authority: 2008013090 Consultant Phone: 816-298-6465
	If a seal is present on this sheet, JSP's have been electronically sealed and dated.
	JOB NUMBER: J9P3678 DUNKLIN COUNTY, MO DATE PREPARED: 7/15/2024
ADDENDUM DATE:	
Only the following items of the Job Special Provisions (Roadway) are authenticated by this seal: All	

JOB
SPECIAL PROVISION

A. General - Federal JSP-09-02K

1.0 Description. The Federal Government is participating in the cost of construction of this project. All applicable Federal laws, and the regulations made pursuant to such laws, shall be observed by the contractor, and the work will be subject to the inspection of the appropriate Federal Agency in the same manner as provided in Sec 105.10 of the Missouri Standard Specifications for Highway Construction with all revisions applicable to this bid and contract.

1.1 This contract requires payment of the prevailing hourly rate of wages for each craft or type of work required to execute the contract as determined by the Missouri Department of Labor and Industrial Relations and requires adherence to a schedule of minimum wages as determined by the United States Department of Labor. For work performed anywhere on this project, the contractor and the contractor's subcontractors shall pay the higher of these two applicable wage rates. State Wage Rates, Information on the Required Federal Aid Provisions, and the current Federal Wage Rates are available on the Missouri Department of Transportation web page at www.modot.org under "Doing Business with MoDOT", "Contractor Resources". Effective Wage Rates will be posted 10 days prior to the applicable bid opening. These supplemental bidding documents have important legal consequences. It shall be conclusively presumed that they are in the bidder's possession, and they have been reviewed and used by the bidder in the preparation of any bid submitted on this project.

1.2 The following documents are available on the Missouri Department of Transportation web page at www.modot.org under "Doing Business with MoDOT"; "Standards and Specifications". The effective version shall be determined by the letting date of the project.

General Provisions & Supplemental Specifications

Supplemental Plans to July 2024 Missouri Standard Plans
For Highway Construction

These supplemental bidding documents contain all current revisions to the published versions and have important legal consequences. It shall be conclusively presumed that they are in the bidder's possession, and they have been reviewed and used by the bidder in the preparation of any bid submitted on this project.

B. Contract Liquidated Damages JSP-13-01D

1.0 Description. Liquidated Damages for failure or delay in completing the work on time for this contract shall be in accordance with Sec 108.8. The liquidated damages include separate amounts for road user costs and contract administrative costs incurred by the Commission.

2.0 Period of Performance. Prosecution of work is expected to begin on the date specified below in accordance with Sec 108.2. Regardless of when the work is begun on this contract, all work shall be completed on or before the date specified below. Completion by this date shall be in accordance with the requirements of Sec 108.7.1.

Job No.: J9P3678
Route: 164
County: Dunklin

Notice to Proceed: June 9, 2025
Completion Date: November 1, 2026

2.1 Calendar Days. The count of calendar days will begin on the date the contractor starts any construction operations on the project.

Job Number	Calendar Days	Daily Road User Cost
J9P3678	168	\$1,800

3.0 Liquidated Damages for Contract Administrative Costs. Should the contractor fail to complete the work on or before the completion date specified in Section 2.0, or within the number of calendar days specified in Section 2.1, whichever occurs first, the contractor will be charged contract administrative liquidated damages in accordance with Sec 108.8 in the amount of **\$1,500** per calendar day for each calendar day, or partial day thereof, that the work is not fully completed. For projects in combination, these damages will be charged in full for failure to complete one or more projects within the above specified completion date or calendar days.

4.0 Liquidated Damages for Road User Costs. Should the contractor fail to complete the work on or before the completion date specified in Section 2.0, or within the number of calendar days specified in Section 2.1, whichever occurs first, the contractor will be charged road user costs in accordance with Sec 108.8 in the amount specified in Section 2.1 for each calendar day, or partial day thereof, that the work is not fully completed. These damages are in addition to the contract administrative damages and any other damages as specified elsewhere in this contract.

C. Work Zone Traffic Management JSP-02-06N

1.0 Description. Work zone traffic management shall be in accordance with applicable portions of Division 100 and Division 600 of the Standard Specifications, and specifically as follows.

1.1 Maintaining Work Zones and Work Zone Reviews. The Work Zone Specialist (WZS) shall maintain work zones in accordance with Sec 616.3.3 and as further stated herein. The WZS shall coordinate and implement any changes approved by the engineer. The WZS shall ensure all traffic control devices are maintained in accordance with Sec 616, the work zone is operated within the hours specified by the engineer, and will not deviate from the specified hours without prior approval of the engineer. The WZS is responsible to manage work zone delay in accordance with these project provisions. When requested by the engineer, the WZS shall submit a weekly report that includes a review of work zone operations for the week. The report shall identify any problems encountered and corrective actions taken. Work zones are subject to unannounced inspections by the engineer and other departmental staff to corroborate the validity of the WZS's review and may require immediate corrective measures and/or additional work zone monitoring.

1.2 Work Zone Deficiencies. Failure to make corrections on time may result in the engineer suspending work. The suspension will be non-excusable and non-compensable regardless if road user costs are being charged for closures.

2.0 Traffic Management Schedule.

2.1 Traffic management schedules shall be submitted to the engineer for review prior to the start of work and prior to any revisions to the traffic management schedule. The traffic management

schedule shall include the proposed traffic control measures, the hours traffic control will be in place, and work hours.

2.2 The traffic management schedule shall conform to the limitations specified in Sec 616 regarding lane closures, traffic shifts, road closures and other width, height and weight restrictions.

2.3 The engineer shall be notified as soon as practical of any postponement due to weather, material or other circumstances.

2.4 In order to ensure minimal traffic interference, the contractor shall schedule lane closures for the absolute minimum amount of time required to complete the work. Lanes shall not be closed until material is available for continuous construction and the contractor is prepared to diligently pursue the work until the closed lane is opened to traffic.

3.0 Work Hour Restrictions.

3.1 Except for emergency work, as determined by the engineer, and long term lane closures required by project phasing, all lanes shall be scheduled to be open to traffic during the five major holiday periods shown below, from 12:00 noon on the last working day preceding the holiday until 6:00 a.m. on the first working day subsequent to the holiday unless otherwise approved by the engineer.

- Memorial Day
- Labor Day
- Thanksgiving
- Christmas
- New Year's Day

3.1.1 Independence Day. The lane restrictions specified in Section 3.1 shall also apply to Independence Day, except that the restricted periods shall be as follows:

When Independence Day falls on:	The Holiday is Observed on:	Halt Lane Closures beginning at:	Allow Lane Closures to resume at:
Sunday	Monday	Noon on Friday	6:00 a.m. on Tuesday
Monday	Monday	Noon on Friday	6:00 a.m. on Tuesday
Tuesday	Tuesday	Noon on Monday	6:00 a.m. on Wednesday
Wednesday	Wednesday	Noon on Tuesday	6:00 a.m. on Thursday
Thursday	Thursday	Noon on Wednesday	6:00 a.m. on Friday
Friday	Friday	Noon on Thursday	6:00 a.m. on Monday
Saturday	Friday	Noon on Thursday	6:00 a.m. on Monday

3.2 The contractor shall not perform any construction operation on the roadway, roadbed or active lanes, including the hauling of material within the project limits, during restricted periods, holiday periods or other special events specified in the contract documents.

3.3 The contractor shall be aware that traffic volume data indicates construction operations on the roadbed between the following hours will likely result in traffic queues greater than 15 minutes. Based on this, the contractor's operations will be restricted accordingly unless it can be

successfully demonstrated the operations can be performed without a 15 minute queue in traffic. It shall be the responsibility of the engineer to determine if the above work hours may be modified. Working hours for evenings, weekends and holidays will be determined by the engineer.

4.0 Detours and Lane Closures.

4.1 When a changeable message sign (CMS) is provided, the contractor shall use the CMS to notify motorists of future traffic disruption and possible traffic delays one week before traffic is shifted to a detour or prior to lane closures. The CMS shall be installed at a location as approved or directed by the engineer. If a CMS with Communication Interface is required, then the CMS shall be capable of communication prior to installation on right of way. All messages planned for use in the work zone shall be approved and authorized by the engineer or its designee prior to deployment. When permanent dynamic message signs (DMS) owned and operated by MoDOT are located near the project, they may also be used to provide warning and information for the work zone. Permanent DMS shall be operated by the TMC, and any messages planned for use on DMS shall be approved and authorized by the TMC at least 72 hours in advance of the work.

4.2 Access shall be maintained for the properties between bridges A9439 and A9440 at all times.

5.0 Basis of Payment. No direct payment will be made to the contractor to recover the cost of equipment, labor, materials, or time required to fulfill the above provisions, unless specified elsewhere in the contract document. All authorized changes in the traffic control plan shall be provided for as specified in Sec 616.

D. Emergency Provisions and Incident Management JSP-90-11A

1.0 The contractor shall have communication equipment on the construction site or immediate access to other communication systems to request assistance from law enforcement or other emergency agencies for incident management. In case of traffic accidents or the need for law enforcement to direct or restore traffic flow through the job site, the contractor shall notify law enforcement or other emergency agencies immediately as needed. The area engineer's office shall also be notified when the contractor requests emergency assistance.

2.0 In addition to the 911 emergency telephone number for ambulance, fire or law enforcement services, the following agencies may also be notified for accident or emergency situation within the project limits.

Missouri Highway Patrol, Troop E – (573) 840-9500		
Dunklin County, MO		
Sheriff: 573-888-2409		

2.1 This list is not all inclusive. Notification of the need for wrecker or tow truck services will remain the responsibility of the appropriate law enforcement agency.

2.2 The contractor shall notify law enforcement and emergency agencies before the start of construction to request their cooperation and to provide coordination of services when emergencies arise during the construction at the project site. When the contractor completes this notification with law enforcement and emergency agencies, a report shall be furnished to the engineer on the status of incident management.

3.0 No direct pay will be made to the contractor to recover the cost of the communication equipment, labor, materials or time required to fulfill the above provisions.

E. Project Contact for Contractor/Bidder Questions JSP-96-05

All questions concerning this project during the bidding process shall be forwarded to the project contact listed below.

Tim Pickett, Project Contact
Southeast District
2675 N Main
Sikeston, MO 63801

Telephone Number: 573-472-9003
Email: Timothy.Pickett@modot.mo.gov

All questions concerning the bid document preparation can be directed to the Central Office – Design at (573) 751-2876.

F. Supplemental Revisions JSP-18-01FF

- Compliance with [2 CFR 200.216 – Prohibition on Certain Telecommunications and Video Surveillance Services or Equipment](#).

The Missouri Highways and Transportation Commission shall not enter into a contract (or extend or renew a contract) using federal funds to procure or obtain equipment, services, or systems that uses covered telecommunications equipment or services as substantial or as critical technology as part of any system where the video surveillance and telecommunications equipment was produced by Huawei Technologies Company, ZTE Corporation, Hytera Communications Corporation, Hangzhou Hikvision Digital Technology Company, or Dahua Technology Company (or any subsidiary or affiliate of such entities).

- Stormwater Compliance Requirements

1.0 Description. This provision requires the contractor to provide a Water Pollution Control Manager (WPCM) for any project that includes land disturbance on the project site and the total area of land disturbance, both on the project site, and all Off-site support areas, is one (1) acre or more. Regardless of the area of Off-site disturbance, if no land disturbance occurs on the project site, these provisions do not apply. When a WPCM is required, all sections within this provision shall be applicable, including assessment of specified Liquidated Damages for failure to correct Stormwater Deficiencies, as specified herein. This provision is in addition to any other stormwater, environmental, and land disturbance requirements specified elsewhere in the contract.

1.1 Definitions. The project site is defined as all areas designated on the plans, including temporary and permanent easements. The project site is equivalent to the “permitted site”, as defined in MoDOT’s State Operating Permit. An Off-site area is defined as any location off the

project site the contractor utilizes for a dedicated project support function, such as, but not limited to, staging area, plant site, borrow area, or waste area.

1.2 Reporting of Off-Site Land Disturbance. If the project includes any planned land disturbance on the project site, prior to the start of work, the contractor shall submit a written report to the engineer that discloses all Off-site support areas where land disturbance is planned, the total acreage of anticipated land disturbance on those sites, and the land disturbance permit number(s). Upon request by the engineer, the contractor shall submit a copy of its land disturbance permit(s) for Off-site locations. Based on the total acreage of land disturbance, both on and Off-site, the engineer shall determine if these Stormwater Compliance Requirements shall apply. The Contractor shall immediately report any changes to the planned area of Off-site land disturbance. The Contractor is responsible for obtaining its own separate land disturbance permit for Off-site areas.

2.0 Water Pollution Control Manager (WPCM). The Contractor shall designate a competent person to serve as the Water Pollution Control Manager (WPCM) for projects meeting the description in Section 1.0. The Contractor shall ensure the WPCM completes all duties listed in Section 2.1.

2.1 Duties of the WPCM:

- (a) Be familiar with the stormwater requirements including the current MoDOT State Operating Permit for construction stormwater discharges/land disturbance activities; MoDOT's statewide Stormwater Pollution Prevention Plan (SWPPP); the Corps of Engineers Section 404 Permit, when applicable; the project specific SWPPP, the Project's Erosion & Sediment Control Plan; all applicable special provisions, specifications, and standard drawings; and this provision;
- (b) Successfully complete the MoDOT Stormwater Training Course within the last 4 years. The MoDOT Stormwater Training is a free online course available at MoDOT.org;
- (c) Attend the Pre-Activity Meeting for Grading and Land Disturbance and all subsequent Weekly Meetings in which grading activities are discussed;
- (d) Oversee and ensure all work is performed in accordance with the Project-specific SWPPP and all updates thereto, or as designated by the engineer;
- (e) Review the project site for compliance with the Project SWPPP, as needed, from the start of any grading operations until final stabilization is achieved, and take necessary actions to correct any known deficiencies to prevent pollution of the waters of the state or adjacent property owners prior to the engineer's weekly inspections;
- (f) Review and acknowledge receipt of each MoDOT Inspection Report (Land Disturbance Inspection Record) for the Project within forty eight (48) hours of receiving the report and ensure that all Stormwater Deficiencies noted on the report are corrected as soon as possible, but no later than stated in Section 5.0.

3.0 Pre-Activity Meeting for Grading/Land Disturbance and Required Hold Point. A Pre-Activity meeting for grading/land disturbance shall be held prior to the start of any land disturbance operations. No land disturbance operations shall commence prior to the Pre-Activity meeting except work necessary to install perimeter controls and entrances. Discussion items at the pre-

activity meeting shall include a review of the Project SWPPP, the planned order of grading operations, proposed areas of initial disturbance, identification of all necessary BMPs that shall be installed prior to commencement of grading operations, and any issues relating to compliance with the Stormwater requirements that could arise in the course of construction activity at the project.

3.1 Hold Point. Following the pre-activity meeting for grading/land disturbance and subsequent installation of the initial BMPs identified at the pre-activity meeting, a Hold Point shall occur prior to the start of any land disturbance operations to allow the engineer and WPCM the time needed to perform an on-site review of the installation of the BMPs to ensure compliance with the SWPPP is met. Land disturbance operations shall not begin until authorization is given by the engineer.

4.0 Inspection Reports. Weekly and post run-off inspections will be performed by the engineer and each Inspection Report (Land Disturbance Inspection Record) will be entered into a web-based Stormwater Compliance database. The WPCM will be granted access to this database and shall promptly review all reports, including any noted deficiencies, and shall acknowledge receipt of the report as required in Section 2.1 (f.).

5.0 Stormwater Deficiency Corrections. All stormwater deficiencies identified in the Inspection Report shall be corrected by the contractor within 7 days of the inspection date or any extended period granted by the engineer when weather or field conditions prohibit the corrective work. If the contractor does not initiate corrective measures within 5 calendar days of the inspection date or any extended period granted by the engineer, all work shall cease on the project except for work to correct these deficiencies, unless otherwise allowed by the engineer. All impact costs related to this halting of work, including, but not limited to stand-by time for equipment, shall be borne by the Contractor. Work shall not resume until the engineer approves the corrective work.

5.1 Liquidated Damages. If the Contractor fails to complete the correction of all Stormwater Deficiencies listed on the MoDOT Inspection Report within the specified time limit, the Commission will be damaged in various ways, including but not limited to, potential liability, required mitigation, environmental clean-up, fines, and penalties. These damages are not reasonably capable of being computed or quantified. Therefore, the contractor will be charged with liquidated damages specified in the amount of \$2,000 per day for failure to correct one or more of the Stormwater Deficiencies listed on the Inspection Report within the specified time limit. In addition to the stipulated damages, the stoppage of work shall remain in effect until all corrections are complete.

6.0 Basis of Payment. No direct payment will be made for compliance with this provision.

- **Delete Sec 106.9 in its entirety and substitute the following:**

106.9 Buy America Requirements.

Buy America Requirements are waived if the total amount of Federal financial assistance applied to the project, through awards or subawards, is below \$500,000.

106.9.1 Buy America Requirements for Iron and Steel.

On all federal-aid projects, the contractor's attention is directed to Title 23 CFR 635.410 *Buy America Requirements*. Where steel or iron products are to be permanently incorporated into the contract work, steel and iron material shall be manufactured, from the initial melting stage through the application of coatings, in the USA except for "minimal use" as described herein. Furthermore,

any coating process of the steel or iron shall be performed in the USA. Under a general waiver from FHWA the use of pig iron and processed, pelletized, and reduced iron ore manufactured outside of the USA will be permitted in the domestic manufacturing process for steel or iron material.

106.9.1.1 Buy America Requirements for Iron and Steel for Manufactured items.

A manufactured item will be considered iron and steel if it is “predominantly” iron or steel. Predominantly iron or steel means that the cost of iron or steel content of a product is more than 50 percent of the total cost of all its components.

106.9.2 Any sources other than the USA as defined will be considered foreign. The required domestic manufacturing process shall include formation of ingots and any subsequent process. Coatings shall include any surface finish that protects or adds value to the product.

106.9.3 “Minimal use” of foreign steel, iron or coating processes will be permitted, provided the cost of such products does not exceed 1/10 of one percent (0.1 percent) of the total contract cost or \$2,500.00, whichever is greater. If foreign steel, iron, or coating processes are used, invoices to document the cost of the foreign portion, as delivered to the project, shall be provided and the engineer’s written approval obtained prior to placing the material in any work.

106.9.4 Buy America requirements include a step certification for all fabrication processes of all steel or iron materials that are accepted per Sec 1000. The AASHTO Product Evaluation and Audit Solutions compliance program verifies that all steel and iron products fabrication processes conform to 23 CFR 635.410 Buy America Requirements and is an acceptable standard per 23 CFR 635.410(d). AASHTO Product Evaluation and Audit Solutions compliant suppliers will not be required to submit step certification documentation with the shipment for some selected steel and iron materials. The AASHTO Product Evaluation and Audit Solutions compliant supplier shall maintain the step certification documentation on file and shall provide this documentation to the engineer upon request.

106.9.4.1 Items designated as Category 1 will consist of steel girders, piling, and reinforcing steel installed on site. Category 1 items require supporting documentation prior to incorporation into the project showing all steps of manufacturing, including coating, as being completed in the United States and in accordance with CFR Title 23 Section 635.410 Buy America Requirements. This includes the Mill Test Report from the original producing steel mill and certifications documenting the manufacturing process for all subsequent fabrication, including coatings. The certification shall include language that certifies the following. That all steel and iron materials permanently incorporated in this project was procured and processed domestically and all manufacturing processes, including coating, as being completed in the United States and in accordance with CFR Title 23 Section 635.410.

106.9.4.2 Items designated as Category 2 will include all other steel or iron products not in Category 1 and permanently incorporated in the project. Category 2 items shall consist of, but not be limited to items such as fencing, guardrail, signing, lighting and signal supports. The prime contractor is required to submit a material of origin form certification prior to incorporation into the project from the fabricator for each item that the product is domestic. The Certificate of Materials Origin form ([link to certificate form](#)) from the fabricator must show all steps of manufacturing, including coating, as being completed in the United States and in accordance with CFR Title 23 Section 635.410 Buy America Requirements and be signed by a fabricator representative. The engineer reserves the right to request additional information and documentation to verify that all Buy America requirements have been satisfied. These documents shall be submitted upon

request by the engineer and retained for a period of 3 years after the last reimbursement of the material.

106.9.4.3 Any minor miscellaneous steel or iron items that are not included in the materials specifications shall be certified by the prime contractor as being procured domestically. Examples of these items would be bolts for sign posts, anchorage inserts, etc. The certification shall read “I certify that all steel and iron materials permanently incorporated in this project during all manufacturing processes, including coating, as being completed in the United States and in accordance with CFR Title 23 Section 635.410 Buy America Requirements procured and processed domestically in accordance with CFR Title 23 Section 635.410 Buy America Requirements. Any foreign steel used was submitted and accepted under minor usage”. The certification shall be signed by an authorized representative of the prime contractor.

106.9.5 When permitted in the contract, alternate bids may be submitted for foreign steel and iron products. The award of the contract when alternate bids are permitted will be based on the lowest total bid of the contract based on furnishing domestic steel or iron products or 125 percent of the lowest total bid based on furnishing foreign steel or iron products. If foreign steel or iron products are awarded in the contract, domestic steel or iron products may be used; however, payment will be at the contract unit price for foreign steel or iron products.

106.9.6 Buy America Requirements for Construction Materials other than iron and steel materials. Construction materials means articles, materials, or supplies that consist of only one of the items listed. Minor additions of articles, materials, supplies, or binding agents to a construction material do not change the categorization of the construction material. Upon request by the engineer, the contractor shall submit a domestic certification for all construction materials listed that are incorporated into the project.

- (a) Non-ferrous metals
- (b) Plastic and Polymer-based products (including polyvinylchloride, composite building materials, and polymers used in fiber optic cables)
- (c) Glass (including optic glass)
- (d) Fiber optic cable (including drop cable)
- (e) Optical fiber
- (f) Lumber
- (g) Engineered wood
- (h) Drywall

106.9.6.1 Minimal Use allowance for Construction Materials other than iron or steel.

“The total value of the non-compliant products is no more than the lesser of \$1,000,000 or 5% of total applicable costs for the project.” The contractor shall submit to the engineer any non-domestic materials and their total material cost to the engineer. The contractor and the engineer will both track these totals to assure that the minimal usage allowance is not exceeded.

106.9.7 Buy America Requirements for Manufactured Products.

Manufactured products means:

- (a) Articles, materials, or supplies that have been:
 - (i) Processed into a specific form and shape; or
 - (ii) Combined with other articles, materials, or supplies to create a product with different properties than the individual articles, materials, or supplies.

- (b) If an item is classified as an iron or steel product, a construction material, or a section 70917(c) material under § 184.4(e) and the definitions set forth in this section, then it is not a manufactured product. However, an article, material, or supply classified as a manufactured product under § 184.4(e) and paragraph (1) of this definition may include components that are construction materials, iron or steel products, or section 70917(c) materials.

106.9.7.1 Manufactured products are exempt from Buy America requirements. To qualify as a manufactured product, items that consist of two or more of the listed construction materials that have been combined together through a manufacturing process, and items that include at least one of the listed materials combined with a material that is not listed through a manufacturing process, should be treated as manufactured products, rather than as construction materials.

106.9.7.2 Manufactured items are covered under a general waiver to exclude them from Buy America Requirements. To qualify for the exemption the components must comprise of 55% of the value of materials in the item. The final assembly must also be performed domestically.

- Pavement Marking Paint Requirements for Standard Waterborne and Temporary

1.0 Description. High Build acrylic waterborne pavement marking paint shall be used in lieu of standard acrylic waterborne pavement marking paint for all Standard Waterborne Pavement Marking Paint items and all Temporary Pavement Marking Paint items. Paint thickness, bead type, bead application rate, retroreflectivity requirements, and all other specifications shall remain as stated in the Missouri Standard Specifications for Highway Construction, except as otherwise amended in the contract documents.

2.0 Material Requirements. Material requirements for Sec 620.20.2.5 Standard Waterborne Paint, and Sec 620.10.2 Temporary Pavement Marking Paint shall be per Sec 1048.20.1.2 High Build Acrylic Waterborne Pavement Marking Paint.

- Third-Party Test Waiver for Concrete Aggregate

1.0 Description. Third party tests may be allowed for determining the durability factor for concrete pavement and concrete masonry aggregate.

2.0 Material. All aggregate for concrete shall be in accordance with Sec 1005.

2.1 MoDOT personnel shall be present at the time of sampling at the quarry. The aggregate sample shall be placed in an approved tamper-evident container (provided by the quarry) for shipment to the third-party testing facility.

2.2 AASHTO T 161 Method B Resistance of Concrete to Rapid Freezing and Thawing, shall be used to determine the aggregate durability factor. All concrete beams for testing shall be 3-inch wide by 4-inch deep by 16-inch long or 3.5-inch wide by 4.5-inch deep by 16-inch long. All beams for testing shall receive a 35-day wet cure fully immersed in saturated lime water prior to initiating the testing process.

2.3 Concrete test beams shall be made using a MoDOT approved concrete pavement mix design.

3.0 Testing Facility Requirements. All third-party test facilities shall meet the requirements outlined in this provision.

3.1 The testing facility shall be AASHTO accredited.

3.1.1 For tests ran after January 1, 2025, accreditation documentation shall be on file with the Construction and Materials Division prior to any tests being performed.

3.1.2 Construction and Materials Division may consider tests completed prior to January 1, 2025, to be acceptable if all sections of this provision are met, with the exception of 3.1.1. Accreditation documentation shall be provided with the test results for tests completed prior to January 1, 2025. No tests completed prior to September 1, 2024, will be accepted.

3.2 The testing facility shall provide their testing process, list of equipment, equipment calibration documentation, and testing certifications or qualifications of technicians performing the AASHTO T 161 Procedure B tests. The testing facility shall provide details on their freezing and thawing apparatus including the time and temperature profile of their freeze-thaw chamber. The profile shall include the temperature set points throughout the entirety of the freeze-thaw cycle. The profile shall show the cycle time at which the apparatus drains/fills with water and the cycle time at which the apparatus begins cooling the specimens.

3.3 Results, no more than five years old, from the third-party test facility shall compare within ± 2.0 percent of an independent test from another AASHTO accredited test facility or with MoDOT test records, in order to be approved for use (e.g. test facility results in a durability factor of 79, MoDOT's recent durability test factor is 81; this compared within +2 percent). The independent testing facility shall be in accordance with this provision. The comparison test can be from a different sample of the same ledge combination.

3.4 When there is a dispute between the third party durability test results and MoDOT durability test results, the MoDOT durability test result shall govern.

3.5 Test results shall be submitted to MoDOT's Construction and Materials division electronically for final approval. Test results shall include raw data for all measurements of relative modulus of elasticity and percent length change for each individual concrete specimen. Raw data shall include initial measurements made at zero cycles and every subsequent measurement of concrete specimens. Raw data shall include the cycle count and date each measurement was taken. Test results shall also include properties of the concrete mixture as required by AASHTO T 161. This shall include the gradation of the coarse aggregate sample. If AASHTO T 152 is used to measure fresh air content, then the aggregate correction factor for the mix determined in accordance with AASHTO T 152 shall also be included.

4.0 Method of Measurement. There is no method of measurement for this provision. The testing requirements and number of specimens shall be in accordance with AASHTO T 161 Procedure B.

5.0 Basis of Payment. No direct payment will be made to the contractor or quarry to recover the cost of aggregate samples, sample shipments, testing equipment, labor to prepare samples or test samples, or developing the durability report.

- **Delete paragraph 15.0 of the General Provision Disadvantaged Business Enterprise (DBE) Program Requirements and substitute the following:**

15.0 Bidder’s List Quote Summary. MoDOT is a recipient of federal funds and is required by 49 CFR 26.11 to provide data about its DBE program. All bidders who seek to work on federally assisted contracts must submit data about all DBE and non-DBEs in accordance with Sec 102.7.9. MoDOT will not compare the submitted Bidder’s List Quote Summary to any other documents or submittals, pre or post award. All information will be used by MoDOT in accordance with 49 CFR 26.11 for reporting to USDOT and to aid in overall DBE goal setting.

- **Add Sec 102.7.9 to include the following:**

102.7.9 Bidder’s List Quote Summary. Each bidder shall submit with each bid a summary of all subcontractors, suppliers, manufacturers, and truckers considered on federally funded projects pursuant to 49 CFR 26.11. The bidder will provide the firm’s name, the corresponding North American Industry Classification System (NAICS) code(s) the firm(s) were considered for, and whether or not they were used in the bid. The information submitted should be the most complete information available at the time of bid. The information shall be disclosed on the Bidder’s List Quote Summary form provided in the bidding documents and submitted in accordance with Sec 102.10. Failure to disclose this information may result in a bid being declared irregular.

G. Utilities JSP-93-26F

1.0 For informational purposes only, the following is a list of names, addresses, and telephone numbers of the known utility companies in the area of the construction work for this improvement:

<u>Utility Name</u>	<u>Known Required Adjustment</u>	<u>Type</u>
AT&T Distribution Ken Lovette 600 W Pine Poplar Bluff, MO 63901 Phone: 573-686-1152 Mobile: 573-300-0490 Email: kl6298@att.com	Yes Section 2.1	Communications
Pemiscot County PWSD 1 Angie/Duey 309 E Broadway St Hayti, MO 63851 Phone: 573-359-1713 Email: conpwsd@sbglobal.net	None Section 2.2	Water

Pemiscot Dunklin Electric Co. Andy 1240 Riggs St Kennett, MO 63857 Phone: 573-757-6641 Email: andy@pdec.coop	None Section 2.3	Fiber & Electric
--	---------------------	------------------

1.1 The existence and approximate location of utility facilities known to exist, as shown on the plans, are based upon the best information available to the Owner at this time. This information is provided by the Owner "as-is" and the Owner expressly disclaims any representation or warranty as to the completeness, accuracy, or suitability of the information for any use. Reliance upon this information is done at the risk and peril of the user, and the Owner shall not be liable for any damages that may arise from any error in the information. It is, therefore, the responsibility of the contractor to verify the above listing information indicating existence, location and status of any facility. Such verification includes direct contact with the listed utilities.

2.0 Project Specific Provisions:

2.1 AT&T Distribution - currently has two (2) lines located within the project limits at various locations. One of the lines is a fiber line with no adjustments anticipated and the other is a copper cable that will be cut and retired. Contact Ken Lovette four (4) weeks prior to start of construction.

2.2 Pemiscot County PWS D 1 – has a water line located north of the existing power poles located to the north. No adjustments are anticipated. The contractor shall contact Angie or Duey four (4) weeks prior to start of construction.

2.3 Pemiscot Dunkin Electric Company – fiber is present north of A9439 and south side of A9440 and appears to be no conflict. Overhead electric is located on north and south side of A9439 and A9440. No adjustments are anticipated. The contractor shall contact Andy, with PDEC, regarding any questions or shielding for Electric and JT for any questions regarding fiber. The contractor shall contact Andy and JT four (4) weeks prior to start of construction.

H. Restrictions for Migratory Birds NJSP-16-06A

1.0 Description. Swallows or other bird species protected by the Migratory Bird Treaty Act may be nesting under the bridge or bridges that will be repaired under this contract.

2.0 Restrictions. To comply with the Migratory Bird Treaty Act, nests of protected species cannot be disturbed when active (eggs or young are present). Generally, nests are active between April 1 and July 31, but active nests can be present outside of these dates.

3.0 Avoidance Measures. The contractor shall not disturb active nests or destroy adults, eggs or young birds. In an effort to comply with the Migratory Bird Treaty Act, the contractor operations will be limited to the options established in the following sections.

3.1 Inactive or Partially Constructed Nests. If nests are present and MoDOT determines that the nests are inactive or partially constructed, the contractor may remove the nests provided that the colony's inactive or partially constructed nests are completely removed by March 15 and the contractor maintains a nest free condition until the bridge work is complete. Dry removal methods

shall be used when practicable. If dry removal is not practicable, hydro cleaning may be used if approved by the Engineer and only if water is free of blasting grit, chemicals, or detergents, and applied using pressure less than 5,000 PSI. Clean water such as that from municipal water treatment plants or wells shall be used. Use of source water from Waters of the State (i.e., streams or lakes), is allowable, if the appropriate methods to prevent the possible spread of invasive aquatic species are implemented.

3.2 Water and Equipment Used for Hydro cleaning. Aquatic invasives such as zebra mussels and some algae species have infested several bodies of water in the United States and can be transported by vessels (barges, boats, tugs, tankers, etc.) and equipment (tanks, tubing, pumps, etc.) that have been used in areas that contain these invasive species. If equipment is not properly inspected and treated to prevent the spread of invasives, these species can be introduced into areas not currently known to have a population. These invasive species are detrimental to existing ecosystems and can outcompete native species. To assist in preventing the introduction and spread of aquatic invasive species through MoDOT projects in Missouri streams and lakes, the following precautions shall be followed.

3.2.1 Use of Water from Streams, Lakes or Ponds. Contractors shall not use water for nest removal from streams, lakes or ponds, unless they have implemented appropriate methods to prevent the possible spread of invasive aquatic species. Water sources from municipal water treatment plants or wells may be used without following these measures provided the equipment to be used has not previously contained waters from streams, lakes or ponds. If the equipment has previously contained waters from other streams or lakes, the following measures must be implemented prior to use.

3.2.1.1 Equipment Washing. Prior to the use or re-use of equipment following any use with water from streams, lakes or ponds, all equipment shall be washed and rinsed thoroughly with hard spray (power wash) and hot (minimum 120° F) water, for at least one minute.

3.2.1.2 Equipment Treating or Drying. Equipment shall be treated or dried in one of the following manners.

3.2.1.2.1 Equipment interior and/or other surfaces shall be treated with a 10% bleach solution to kill any aquatic nuisance species. This solution must also be run through all intake lines and hoses, to sterilize interior components. When chlorine treatment is used, all chlorine runoff from equipment washing must be collected and properly treated and/or disposed of in accordance with Sec 806.

3.2.1.2.2 Equipment interior and/or other surfaces shall be treated with 140° F water for a minimum of 10 seconds contact on all surfaces. 140 ° F water must also be run through all intake lines and hoses, to purge any standing water.

3.2.1.2.3 Equipment shall be flushed of all non-municipal water, and dried thoroughly, in the sun before using in or transporting between streams and lakes. Dry times will depend on the season the equipment is being used. Equipment must dry a minimum of 7 days for June-September, 18 days for March-May; 18 days for October-November, and 30 days for December-February. The drying method should be reserved as a last resort option.

3.2.2 Prior to use of equipment, contractors shall provide the MoDOT inspector written documentation of the equipment's geographic origin (including the water body it was last used in), as well as defining the specified treatment method used to adequately ensure protection

against invasive species. The written documentation will include a statement indicating the contractor is aware of these provisions and will also treat the equipment appropriately after completion of the project.

3.3 Active Nests. The contractor may work on the bridge if active nests are present, as long as the work does not impact or disturb the birds and/or nests. At a minimum, work shall not be performed within 10 feet of an active nest; however, the contractor is responsible for ensuring their activities do not impact the nests, eggs, or young.

4.0 Additional Responsibilities. If active bird nests remain after all reasonable avoidance measures have been taken, or if bird nests are observed during project construction, the contractor shall notify the Resident Engineer and contact the MoDOT Environmental Section (573-526-4778) to determine if there are other allowable options.

I. Liquidated Damages for Winter Months JSP-04-17A

Delete Sec 108.8.1.3 (a)

Liquidated damages for failure to complete the work on time shall not be waived from December 15 to March 15, both dates inclusive.

J. Contractor Quality Control NJSP-15-42

1.0 The contractor shall perform Quality Control (QC) testing in accordance with the specifications and as specified herein. The contractor shall submit a Quality Control Plan (QC Plan) to the engineer for approval that includes all items listed in Section 2.0, prior to beginning work.

2.0 Quality Control Plan.

- (a) The name and contact information of the person in responsible charge of the QC testing.
- (b) A list of the QC technicians who will perform testing on the project, including the fields in which they are certified to perform testing.
- (c) A proposed independent third party testing firm for dispute resolution, including all contact information.
- (d) A list of Hold Points, when specified by the engineer.
- (e) The MoDOT Standard Inspection and Testing Plan (ITP). This shall be the version that is posted at the time of bid on the MoDOT website (www.modot.org/quality).

3.0 Quality Control Testing and Reporting. Testing shall be performed per the test method and frequency specified in the ITP. All personnel who perform sampling or testing shall be certified in the MoDOT Technician Certification Program for each test that they perform.

3.1 Reporting of Test Results. All QC test reports shall be submitted as soon as practical, but no later than the day following the test. Test data shall be immediately provided to the engineer upon request at any time, including prior to the submission of the test report. No payment will be made for the work performed until acceptable QC test results have been received by the engineer and confirmed by QA test results.

3.1.1 Test results shall be reported on electronic forms provided by MoDOT. Forms and Contractor Reporting Excel2Oracle Reports (CRE2O) can be found on the MoDOT website. All required forms, reports and material certifications shall be uploaded to a Microsoft SharePoint® site provided by MoDOT, and organized in the file structure established by MoDOT.

3.2 Non-Conformance Reporting. A Non-Conformance Report (NCR) shall be submitted by the contractor when the contractor proposes to incorporate material into the work that does not meet the testing requirements or for any work that does not comply with the contract terms or specifications.

3.2.1 Non-Conformance Reporting shall be submitted electronically on the Non-Conformance Report form provided on the MoDOT Website. The NCR shall be uploaded to the MoDOT SharePoint® site and an email notification sent to the engineer.

3.2.2 The contractor shall propose a resolution to the non-conforming material or work. Acceptance of a resolution by the engineer is required before closure of the non-conformance report.

4.0 Work Planning and Scheduling.

4.1 Two-week Schedule. Each week, the contractor shall submit to the engineer a schedule that outlines the planned project activities for the following two-week period. The two-week schedule shall detail all work and traffic control events planned for that period and any Hold Points specified by the engineer.

4.2 Weekly Meeting. When work is active, the contractor shall hold a weekly project meeting with the engineer to review the planned activities for the following week and to resolve any outstanding issues. Attendees shall include the engineer, the contractor superintendent or project manager and any foreman leading major activities. This meeting may be waived when, in the opinion of the engineer, a meeting is not necessary. Attendees may join the meeting in person, by phone or video conference.

4.3 Pre-Activity Meeting. A pre-activity meeting is required in advance of the start of each new activity, except when waived by the engineer. The purpose of this meeting is to review construction details of the new activity. At a minimum, the discussion topics shall include: safety precautions, QC testing, traffic impacts, and any required Hold Points. Attendees shall include the engineer, the contractor superintendent and the foreman who will be leading the new activity. Pre-activity meetings may be held in conjunction with the weekly project meeting.

4.4 Hold Points. Hold Points are events that require approval by the engineer prior to continuation of work. Hold Points occur at definable stages of work when, in the opinion of the engineer, a review of the preceding work is necessary before continuation to the next stage.

4.4.1 A list of typical Hold Point events is available on the MoDOT website. Use of the Hold Point process will only be required for the project-specific list of Hold Points, if any, that the engineer submits to the contractor in advance of the work. The engineer may make changes to the Hold Point list at any time.

4.4.2 Prior to all Hold Point inspections, the contractor shall verify the work has been completed in accordance with the contract and specifications. If the engineer identifies any corrective actions needed during a Hold Point inspection, the corrections shall be completed prior to continuing

work. The engineer may require a new Hold Point to be scheduled if the corrections require a follow-up inspection. Re-scheduling of Hold Points require a minimum 24-hour advance notification from the contractor unless otherwise allowed by the engineer.

5.0 Quality Assurance Testing and Inspection. MoDOT will perform quality assurance testing and inspection of the work, except as specified herein. The contractor shall utilize the inspection checklists provided in the ITP as a guide to minimize findings by MoDOT inspection staff. Submittal of completed checklists is not required, except as specified in 5.1.

5.1 Inspection and testing required in the production of concrete for the project shall be the responsibility of the contractor. Submittal of the 501 Concrete Plant Checklist is required.

6.0 Basis of Payment. No direct payment will be made for compliance with this provision.

K. Modified Linear Grading Class 2

1.0 Description. Modified Linear Grading, Class 2, shall consist of contractor-furnished fill, embankment construction, excavating and grading existing shoulders to facilitate placement of pavement and base, grading of ditches and slopes, and final shaping necessary to conform to the lines and grades in the plans, and shall conform to all applicable portions of Sec 207 and specifically as follows.

2.0 Construction Requirements.

2.1 It may be necessary to go outside the limits of the right of way to obtain additional material. All contractor furnished material shall be approved by the Engineer prior to being incorporated into the project.

2.2 The Engineer shall have sole discretion in determining whether excess material may be incorporated within right-of-way or must be disposed of outside of right-of-way.

2.3 All areas to be graded shall be cleared and grubbed in accordance with Sec 201 or as directed by the Engineer. No measurement or payment will be made for clearing and grubbing.

2.4 Roadside ditches shall be graded to match the existing flowline unless shown otherwise in the plans. Grading for pipe extensions shall match the projected flowline of the existing pipe.

2.5 Any damage to existing drainage structures or existing pavement, resulting from the Contractor's operations, shall be repaired at the Contractor's expense and to the satisfaction of the Engineer.

3.0 Method of Measurement. Measurement will be made to the nearest 1/10 station for the length of grading measured along the centerline of the traveled way.

4.0 Basis of Payment. All costs incurred by the Contractor to comply with this provision shall be considered completely covered by the contract unit price for Item 207-99.09, Modified Linear Grading, Class 2. No direct payment will be made for contractor furnished material or disposal of excess material.

L. Damage to Existing Roadways and Entrances

1.0 Description. This work shall consist of repairing any damage to existing pavement, shoulders, side roads, and entrances caused by Contractor operations. This shall include, but is not limited to, damage caused by the traffic during Contractor operations within the project limits including the work zone signing.

2.0 Construction Requirements. Any cracking, gouging, or other damage to the existing pavement, shoulders, side roads, or entrances from general construction shall be repaired within twenty-four (24) hours of the time of damage at the Contractor's expense. Repair of the damaged pavement, shoulders, side roads, or entrances shall be as determined by the Engineer.

3.0 Method of Measurement. No measurement of damaged pavement, shoulder, side roads, or entrances, as described above, shall be made.

4.0 Basis of Payment. No payment will be made for repairs to existing pavement, shoulders, side roads or entrances damaged by Contractor operations.

M. Temporary Stream Crossings and Workpads

1.0 Description. This work shall include construction of a temporary stream crossing or workpad to facilitate the placement of the Contractor's equipment in the stream, in accordance with Division 100 of the General Provisions, Section 806.1 of the Standard Specifications, and as follows.

2.0 Construction Requirements. The Contractor shall be solely responsible for the design, installation, maintenance, and removal of the temporary stream crossing or workpad, as well as any structures installed to maintain proper flow while the temporary crossing or workpad is in place.

2.1 Temporary crossings and workpads shall be constructed of clean rock fill in accordance with Sec 303.2, except Sec 303.2.3 shall not apply.

2.2 The Contractor shall design the temporary crossing or workpad, including the size and number of pipes, to maintain normal flows, prevent upstream flooding, and allow free movement of aquatic life in the stream.

2.3 Storm water from the approaches to temporary crossings or workpads must be diverted to appropriate erosion control devices to allow sediment-laden runoff to be treated prior to entering the stream.

2.4 Pipes shall be anchored to prevent being swept from the project during high flows.

2.5 Temporary stream crossings and workpads shall not conflict with existing utilities. Any utilities that conflict with the construction of a temporary crossing/workpad or operation of equipment on a temporary crossing/workpad shall be relocated at the Contractor's expense.

3.0 Basis of Payment. No direct payment will be made for any equipment, labor, material, or time involved with the design, installation, maintenance, or removal of temporary stream crossings and workpads. The contractor shall be responsible for all costs, including damage and penalties.

N. DBE Prompt Payment Reporting JSP-24-05B

1.0 Description.

1.1 This provision will only apply to contracts that have a Disadvantaged Business Enterprise (DBE) goal greater than 0% and have at least one DBE subcontractor.

1.2 MoDOT monitors the payments made by prime contractors and subcontractors to DBEs for compliance with DBE payment monitoring rules as outlined in 49 CFR 26.37. To facilitate this monitoring, MoDOT requires prime contractors to report their remitted payments to DBEs and subcontractors to report their remitted payments to lower-tier DBEs.

1.3 Tracking of DBE payments are made through the Signet™ application (Signet). Signet is a third-party service, supported by the vendor, for usage by the prime contractor and all subcontractors. Signet is only a reporting tool; it does not process financial transactions. MoDOT does not provide direct technical support for Signet. Information about Signet may be found at <https://signet-help.zendesk.com/hc/en-us>.

1.4 Upon completion of the first pay estimate on the contract, Signet will automatically send an email to the prime contractor prompting registration. The prime will be required to pay a one-time, fixed fee of \$1,000 for this contract directly to the Signet vendor. Use of Signet to track DBE payments will be available for the life of the contract, regardless of the contract value, contract duration, number of subcontractors, or payments reported. No additional fee will be charged to subcontractors that are required to report payments or DBEs that are required to verify payments through Signet. The contractor may also, at no additional cost, report payments through Signet to subcontractors that are not DBEs.

1.5 After each estimate, when contractor reporting of payments is complete, the subcontractor will receive an email notifying them of the payment and requesting verification of the reported payment. A subcontractor that has not completed registration with Signet will be prompted to do so at this time.

1.6 Users will be set up automatically based on information in MoDOT's vendor list. Additional users under each contractor may be added once registration has been completed within Signet. The current vendor list can be found at <https://www.modot.org/bid-opening-info>.

1.7 For purposes of this requirement, payer is defined as the prime contractor or subcontractor that reports a payment in Signet to a vendor that is either a subcontractor, trucker, manufacturer, regular dealer, or broker. Payee is defined as the vendor that receives notification of payment through Signet from the prime contractor or a higher-tier subcontractor. Payment is defined as issuing an Electronic Funds Transfer (EFT) or mailing a check to a payee.

2.0 Requirements. Payers must report remitted payment to DBEs within Signet, for work performed by the DBE subcontractor, DBE trucking, materials supplied from a DBE manufacturer, dealer, or broker, as well as a return of retainage (and/or other amounts withheld), within 15 calendar days.

2.1 Prime contractors must report remitted payments to DBEs within 15 calendar days of each payment it receives from MoDOT. Prime contractors must also report payments to non-DBE

subcontractors if that subcontractor is making payment to a lower tier DBE subcontractor, trucker, manufacturer, regular dealer, or broker.

2.2 The payer must report the following information within Signet:

- a. The name of the payee.
- b. The dollar amount of the payment to the payee.
- c. The date the payment was made.
- d. Any retainage or other amount withheld (if any) and the reason for the withholding (if other than retainage).
- e. The DBE function performed for this payment (e.g., contracting, trucking, or supplying as a manufacturer, dealer, or broker).
- f. Other information required by Signet.

The payer must report its return of retainage (and/or other amounts withheld) in separate, standalone payment entries (i.e., without being comingled with a payment for work performed or materials supplied).

2.3 In the event that no work has been completed by a DBE during the estimate period, such that no payment is due to a DBE subcontractor, trucker, manufacturer, regular dealer, or broker, then the prime contractor will mark payment complete within Signet, and no other payments are required to be reported.

2.4 Each subcontractor making a payment to a lower-tier DBE must report remitted payments within Signet, as detailed in Section 2.2, within 15 days of receipt of each payment from the prime contractor.

2.5 DBE payees must verify in Signet each payment reported by a payer within 15 calendar days of the payment being reported by the payer. This verification includes whether the payment was received, and if so, whether it was as expected.

3.0 Basis of Payment. A fixed cost of \$1,000 will be paid on this contract for the required software to report payments to DBEs through Signet. Regardless of the number of projects in a contract, a single payment will be made under item 108-10.00, SIGNET DBE REPORTING, per lump sum. The engineer reserves the right to underrun this item for any reason. Any additional costs for registration, software, usage, time, labor, or other costs will be considered incidental and no direct payment will be made.

O. Optional Pavements JSP 06-06H

1.0 Description. This work shall consist of a pavement composed of either Portland cement concrete or asphaltic concrete constructed on a prepared subgrade. This work shall be performed in accordance with the standard specifications and as shown on the plans or established by the engineer.

2.0 The quantities shown reflect the total square yards of pavement surface designated for each pavement type as computed and shown on the plans.

2.1 No additional payment will be made for asphaltic concrete mix quantities to construct the required 1:1 slope along the edge of the pavement, or for tack applied between lifts of asphalt.

2.2 No additional payment will be made for aggregate base quantities outside the limits of the final surface area as computed and shown on the plans. When A2 shoulders are specified, payment for aggregate base will be as shown on the plans.

2.3 The grading shown on the plans was designed for the thicker pavement option. For projects with grading in the contract, there will be no adjustment of the earthwork quantities due to adjusting the roadway subgrade for optional pavements.

2.4 The contractor shall comply with Sections 401 through 403 for the asphalt option and Sections 501 and 502 for the concrete option.

2.5 Pavement options composed of Portland cement concrete shall have contrast pavement marking for intermittent markings (skips), dotted lines, and solid intersection lane lines. The pavement markings shall be in accordance with Section 620. No additional payment will be made for the contrast pavement markings.

3.0 Method of Measurement. The quantities of concrete pavement will be measured in accordance with Section 502.14. The quantities of asphaltic concrete pavement will be measured in accordance with Section 403.22.

4.0 Basis of Payment. The accepted quantity of the chosen option will be paid for at the contract unit bid price for Item 403-99.05, Optional Pavement, per square yard.

4.1 For projects with previously graded roadbeds, any additional quantities required to bring the roadway subgrade to the proper elevation will be considered completely covered by the pay item for Subgrading and Shouldering.

4.2 Price Adjustment for Fuel. If the contractor accepts the option for fuel adjustment in the bid proposal, a fuel adjustment will be applied in accordance with Sec 109.14 for the type of pavement constructed.

Job No.: JSE0101
 Route: N
 County: Dunklin

JOB SPECIAL PROVISIONS TABLE OF CONTENTS (ROADWAY)

(Job Special Provisions shall prevail over General Special Provisions whenever in conflict therewith.)

A.	General - Federal JSP-09-02K	1
B.	Contract Liquidated Damages JSP-13-01D	1
C.	Work Zone Traffic Management JSP-02-06N	2
D.	Emergency Provisions and Incident Management JSP-90-11A	4
E.	Project Contact for Contractor/Bidder Questions JSP-96-05	5
F.	Supplemental Revisions JSP-18-01FF	5
G.	Utilities JSP-93-26F	12
H.	Restrictions for Migratory Birds NJSP-16-06A	13
I.	Liquidated Damages for Winter Months JSP-04-17A	15
J.	Contractor Quality Control NJSP-15-42	15
K.	Modified Linear Grading Class 2	17
L.	Damage to Existing Roadways and Entrances	17
M.	Temporary Stream Crossings and Workpads	18
N.	Airport Requirements JSP-15-09	18
O.	DBE Prompt Payment Reporting JSP-24-05B	19
P.	Optional Pavements JSP 06-06H	21

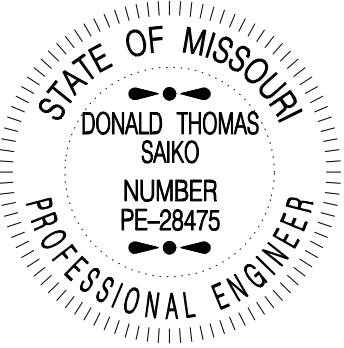
 <p>THIS SHEET HAS BEEN SIGNED, SEALED AND DATED ELECTRONICALLY.</p>	<p>MISSOURI HIGHWAYS AND TRANSPORTATION COMMISSION 105 W. CAPITOL AVE. JEFFERSON CITY, MO 65102 Phone 1-888-275-6636</p>
	<p>GARVER 7509 NW Tiffany Springs Parkway, STE 200</p>
	<p>Certificate of Authority: 2008013090 Consultant Phone: 816-298-6465</p>
	<p>If a seal is present on this sheet, JSP's have been electronically sealed and dated.</p>
	<p>JOB NUMBER: JSE0101 DUNKLIN COUNTY, MO DATE PREPARED: 7/15/2024</p>
<p>ADDENDUM DATE:</p>	
<p>Only the following items of the Job Special Provisions (Roadway) are authenticated by this seal: All</p>	

JOB
SPECIAL PROVISION

A. General - Federal JSP-09-02K

1.0 Description. The Federal Government is participating in the cost of construction of this project. All applicable Federal laws, and the regulations made pursuant to such laws, shall be observed by the contractor, and the work will be subject to the inspection of the appropriate Federal Agency in the same manner as provided in Sec 105.10 of the Missouri Standard Specifications for Highway Construction with all revisions applicable to this bid and contract.

1.1 This contract requires payment of the prevailing hourly rate of wages for each craft or type of work required to execute the contract as determined by the Missouri Department of Labor and Industrial Relations and requires adherence to a schedule of minimum wages as determined by the United States Department of Labor. For work performed anywhere on this project, the contractor and the contractor's subcontractors shall pay the higher of these two applicable wage rates. State Wage Rates, Information on the Required Federal Aid Provisions, and the current Federal Wage Rates are available on the Missouri Department of Transportation web page at www.modot.org under "Doing Business with MoDOT", "Contractor Resources". Effective Wage Rates will be posted 10 days prior to the applicable bid opening. These supplemental bidding documents have important legal consequences. It shall be conclusively presumed that they are in the bidder's possession, and they have been reviewed and used by the bidder in the preparation of any bid submitted on this project.

1.2 The following documents are available on the Missouri Department of Transportation web page at www.modot.org under "Doing Business with MoDOT"; "Standards and Specifications". The effective version shall be determined by the letting date of the project.

General Provisions & Supplemental Specifications

Supplemental Plans to July 2024 Missouri Standard Plans
For Highway Construction

These supplemental bidding documents contain all current revisions to the published versions and have important legal consequences. It shall be conclusively presumed that they are in the bidder's possession, and they have been reviewed and used by the bidder in the preparation of any bid submitted on this project.

B. Contract Liquidated Damages JSP-13-01D

1.0 Description. Liquidated Damages for failure or delay in completing the work on time for this contract shall be in accordance with Sec 108.8. The liquidated damages include separate amounts for road user costs and contract administrative costs incurred by the Commission.

2.0 Period of Performance. Prosecution of work is expected to begin on the date specified below in accordance with Sec 108.2. Regardless of when the work is begun on this contract, all work shall be completed on or before the date specified below. Completion by this date shall be in accordance with the requirements of Sec 108.7.1.

Job No.: JSE0101
Route: N
County: Dunklin

Notice to Proceed: June 9, 2025
Completion Date: November 1, 2026

2.1 Calendar Days. The count of calendar days will begin on the date the contractor starts any construction operations on the project.

Job Number	Calendar Days	Daily Road User Cost
JSE0101	86	\$1,800

3.0 Liquidated Damages for Contract Administrative Costs. Should the contractor fail to complete the work on or before the completion date specified in Section 2.0, or within the number of calendar days specified in Section 2.1, whichever occurs first, the contractor will be charged contract administrative liquidated damages in accordance with Sec 108.8 in the amount of **\$1,500** per calendar day for each calendar day, or partial day thereof, that the work is not fully completed. For projects in combination, these damages will be charged in full for failure to complete one or more projects within the above specified completion date or calendar days.

4.0 Liquidated Damages for Road User Costs. Should the contractor fail to complete the work on or before the completion date specified in Section 2.0, or within the number of calendar days specified in Section 2.1, whichever occurs first, the contractor will be charged road user costs in accordance with Sec 108.8 in the amount specified in Section 2.1 for each calendar day, or partial day thereof, that the work is not fully completed. These damages are in addition to the contract administrative damages and any other damages as specified elsewhere in this contract.

C. Work Zone Traffic Management JSP-02-06N

1.0 Description. Work zone traffic management shall be in accordance with applicable portions of Division 100 and Division 600 of the Standard Specifications, and specifically as follows.

1.1 Maintaining Work Zones and Work Zone Reviews. The Work Zone Specialist (WZS) shall maintain work zones in accordance with Sec 616.3.3 and as further stated herein. The WZS shall coordinate and implement any changes approved by the engineer. The WZS shall ensure all traffic control devices are maintained in accordance with Sec 616, the work zone is operated within the hours specified by the engineer, and will not deviate from the specified hours without prior approval of the engineer. The WZS is responsible to manage work zone delay in accordance with these project provisions. When requested by the engineer, the WZS shall submit a weekly report that includes a review of work zone operations for the week. The report shall identify any problems encountered and corrective actions taken. Work zones are subject to unannounced inspections by the engineer and other departmental staff to corroborate the validity of the WZS's review and may require immediate corrective measures and/or additional work zone monitoring.

1.2 Work Zone Deficiencies. Failure to make corrections on time may result in the engineer suspending work. The suspension will be non-excusable and non-compensable regardless if road user costs are being charged for closures.

2.0 Traffic Management Schedule.

2.1 Traffic management schedules shall be submitted to the engineer for review prior to the start of work and prior to any revisions to the traffic management schedule. The traffic management

schedule shall include the proposed traffic control measures, the hours traffic control will be in place, and work hours.

2.2 The traffic management schedule shall conform to the limitations specified in Sec 616 regarding lane closures, traffic shifts, road closures and other width, height and weight restrictions.

2.3 The engineer shall be notified as soon as practical of any postponement due to weather, material or other circumstances.

2.4 In order to ensure minimal traffic interference, the contractor shall schedule lane closures for the absolute minimum amount of time required to complete the work. Lanes shall not be closed until material is available for continuous construction and the contractor is prepared to diligently pursue the work until the closed lane is opened to traffic.

3.0 Work Hour Restrictions.

3.1 Except for emergency work, as determined by the engineer, and long term lane closures required by project phasing, all lanes shall be scheduled to be open to traffic during the five major holiday periods shown below, from 12:00 noon on the last working day preceding the holiday until 6:00 a.m. on the first working day subsequent to the holiday unless otherwise approved by the engineer.

- Memorial Day
- Labor Day
- Thanksgiving
- Christmas
- New Year's Day

3.1.1 Independence Day. The lane restrictions specified in Section 3.1 shall also apply to Independence Day, except that the restricted periods shall be as follows:

When Independence Day falls on:	The Holiday is Observed on:	Halt Lane Closures beginning at:	Allow Lane Closures to resume at:
Sunday	Monday	Noon on Friday	6:00 a.m. on Tuesday
Monday	Monday	Noon on Friday	6:00 a.m. on Tuesday
Tuesday	Tuesday	Noon on Monday	6:00 a.m. on Wednesday
Wednesday	Wednesday	Noon on Tuesday	6:00 a.m. on Thursday
Thursday	Thursday	Noon on Wednesday	6:00 a.m. on Friday
Friday	Friday	Noon on Thursday	6:00 a.m. on Monday
Saturday	Friday	Noon on Thursday	6:00 a.m. on Monday

3.2 The contractor shall not perform any construction operation on the roadway, roadbed or active lanes, including the hauling of material within the project limits, during restricted periods, holiday periods or other special events specified in the contract documents.

3.3 The contractor shall be aware that traffic volume data indicates construction operations on the roadbed between the following hours will likely result in traffic queues greater than 15 minutes. Based on this, the contractor's operations will be restricted accordingly unless it can be

successfully demonstrated the operations can be performed without a 15 minute queue in traffic. It shall be the responsibility of the engineer to determine if the above work hours may be modified. Working hours for evenings, weekends and holidays will be determined by the engineer.

4.0 Detours and Lane Closures.

4.1 When a changeable message sign (CMS) is provided, the contractor shall use the CMS to notify motorists of future traffic disruption and possible traffic delays one week before traffic is shifted to a detour or prior to lane closures. The CMS shall be installed at a location as approved or directed by the engineer. If a CMS with Communication Interface is required, then the CMS shall be capable of communication prior to installation on right of way. All messages planned for use in the work zone shall be approved and authorized by the engineer or its designee prior to deployment. When permanent dynamic message signs (DMS) owned and operated by MoDOT are located near the project, they may also be used to provide warning and information for the work zone. Permanent DMS shall be operated by the TMC, and any messages planned for use on DMS shall be approved and authorized by the TMC at least 72 hours in advance of the work.

4.2 Access shall be maintained for the properties between bridges A9439 and A9440 at all times.

5.0 Basis of Payment. No direct payment will be made to the contractor to recover the cost of equipment, labor, materials, or time required to fulfill the above provisions, unless specified elsewhere in the contract document. All authorized changes in the traffic control plan shall be provided for as specified in Sec 616.

D. Emergency Provisions and Incident Management JSP-90-11A

1.0 The contractor shall have communication equipment on the construction site or immediate access to other communication systems to request assistance from law enforcement or other emergency agencies for incident management. In case of traffic accidents or the need for law enforcement to direct or restore traffic flow through the job site, the contractor shall notify law enforcement or other emergency agencies immediately as needed. The area engineer's office shall also be notified when the contractor requests emergency assistance.

2.0 In addition to the 911 emergency telephone number for ambulance, fire or law enforcement services, the following agencies may also be notified for accident or emergency situation within the project limits.

Missouri Highway Patrol, Troop E – (573) 840-9500		
Dunklin County, MO		
Sheriff: 573-888-2409		

2.1 This list is not all inclusive. Notification of the need for wrecker or tow truck services will remain the responsibility of the appropriate law enforcement agency.

2.2 The contractor shall notify law enforcement and emergency agencies before the start of construction to request their cooperation and to provide coordination of services when emergencies arise during the construction at the project site. When the contractor completes this notification with law enforcement and emergency agencies, a report shall be furnished to the engineer on the status of incident management.

3.0 No direct pay will be made to the contractor to recover the cost of the communication equipment, labor, materials or time required to fulfill the above provisions.

E. Project Contact for Contractor/Bidder Questions JSP-96-05

All questions concerning this project during the bidding process shall be forwarded to the project contact listed below.

Tim Pickett, Project Contact
Southeast District
2675 N Main
Sikeston, MO 63801

Telephone Number: 573-472-9003
Email: Timothy.Pickett@modot.mo.gov

All questions concerning the bid document preparation can be directed to the Central Office – Design at (573) 751-2876.

F. Supplemental Revisions JSP-18-01FF

- Compliance with [2 CFR 200.216 – Prohibition on Certain Telecommunications and Video Surveillance Services or Equipment](#).

The Missouri Highways and Transportation Commission shall not enter into a contract (or extend or renew a contract) using federal funds to procure or obtain equipment, services, or systems that uses covered telecommunications equipment or services as substantial or as critical technology as part of any system where the video surveillance and telecommunications equipment was produced by Huawei Technologies Company, ZTE Corporation, Hytera Communications Corporation, Hangzhou Hikvision Digital Technology Company, or Dahua Technology Company (or any subsidiary or affiliate of such entities).

- Stormwater Compliance Requirements

1.0 Description. This provision requires the contractor to provide a Water Pollution Control Manager (WPCM) for any project that includes land disturbance on the project site and the total area of land disturbance, both on the project site, and all Off-site support areas, is one (1) acre or more. Regardless of the area of Off-site disturbance, if no land disturbance occurs on the project site, these provisions do not apply. When a WPCM is required, all sections within this provision shall be applicable, including assessment of specified Liquidated Damages for failure to correct Stormwater Deficiencies, as specified herein. This provision is in addition to any other stormwater, environmental, and land disturbance requirements specified elsewhere in the contract.

1.1 Definitions. The project site is defined as all areas designated on the plans, including temporary and permanent easements. The project site is equivalent to the “permitted site”, as defined in MoDOT’s State Operating Permit. An Off-site area is defined as any location off the

project site the contractor utilizes for a dedicated project support function, such as, but not limited to, staging area, plant site, borrow area, or waste area.

1.2 Reporting of Off-Site Land Disturbance. If the project includes any planned land disturbance on the project site, prior to the start of work, the contractor shall submit a written report to the engineer that discloses all Off-site support areas where land disturbance is planned, the total acreage of anticipated land disturbance on those sites, and the land disturbance permit number(s). Upon request by the engineer, the contractor shall submit a copy of its land disturbance permit(s) for Off-site locations. Based on the total acreage of land disturbance, both on and Off-site, the engineer shall determine if these Stormwater Compliance Requirements shall apply. The Contractor shall immediately report any changes to the planned area of Off-site land disturbance. The Contractor is responsible for obtaining its own separate land disturbance permit for Off-site areas.

2.0 Water Pollution Control Manager (WPCM). The Contractor shall designate a competent person to serve as the Water Pollution Control Manager (WPCM) for projects meeting the description in Section 1.0. The Contractor shall ensure the WPCM completes all duties listed in Section 2.1.

2.1 Duties of the WPCM:

- (a) Be familiar with the stormwater requirements including the current MoDOT State Operating Permit for construction stormwater discharges/land disturbance activities; MoDOT's statewide Stormwater Pollution Prevention Plan (SWPPP); the Corps of Engineers Section 404 Permit, when applicable; the project specific SWPPP, the Project's Erosion & Sediment Control Plan; all applicable special provisions, specifications, and standard drawings; and this provision;
- (b) Successfully complete the MoDOT Stormwater Training Course within the last 4 years. The MoDOT Stormwater Training is a free online course available at MoDOT.org;
- (c) Attend the Pre-Activity Meeting for Grading and Land Disturbance and all subsequent Weekly Meetings in which grading activities are discussed;
- (d) Oversee and ensure all work is performed in accordance with the Project-specific SWPPP and all updates thereto, or as designated by the engineer;
- (e) Review the project site for compliance with the Project SWPPP, as needed, from the start of any grading operations until final stabilization is achieved, and take necessary actions to correct any known deficiencies to prevent pollution of the waters of the state or adjacent property owners prior to the engineer's weekly inspections;
- (f) Review and acknowledge receipt of each MoDOT Inspection Report (Land Disturbance Inspection Record) for the Project within forty eight (48) hours of receiving the report and ensure that all Stormwater Deficiencies noted on the report are corrected as soon as possible, but no later than stated in Section 5.0.

3.0 Pre-Activity Meeting for Grading/Land Disturbance and Required Hold Point. A Pre-Activity meeting for grading/land disturbance shall be held prior to the start of any land disturbance operations. No land disturbance operations shall commence prior to the Pre-Activity meeting except work necessary to install perimeter controls and entrances. Discussion items at the pre-

activity meeting shall include a review of the Project SWPPP, the planned order of grading operations, proposed areas of initial disturbance, identification of all necessary BMPs that shall be installed prior to commencement of grading operations, and any issues relating to compliance with the Stormwater requirements that could arise in the course of construction activity at the project.

3.1 Hold Point. Following the pre-activity meeting for grading/land disturbance and subsequent installation of the initial BMPs identified at the pre-activity meeting, a Hold Point shall occur prior to the start of any land disturbance operations to allow the engineer and WPCM the time needed to perform an on-site review of the installation of the BMPs to ensure compliance with the SWPPP is met. Land disturbance operations shall not begin until authorization is given by the engineer.

4.0 Inspection Reports. Weekly and post run-off inspections will be performed by the engineer and each Inspection Report (Land Disturbance Inspection Record) will be entered into a web-based Stormwater Compliance database. The WPCM will be granted access to this database and shall promptly review all reports, including any noted deficiencies, and shall acknowledge receipt of the report as required in Section 2.1 (f.).

5.0 Stormwater Deficiency Corrections. All stormwater deficiencies identified in the Inspection Report shall be corrected by the contractor within 7 days of the inspection date or any extended period granted by the engineer when weather or field conditions prohibit the corrective work. If the contractor does not initiate corrective measures within 5 calendar days of the inspection date or any extended period granted by the engineer, all work shall cease on the project except for work to correct these deficiencies, unless otherwise allowed by the engineer. All impact costs related to this halting of work, including, but not limited to stand-by time for equipment, shall be borne by the Contractor. Work shall not resume until the engineer approves the corrective work.

5.1 Liquidated Damages. If the Contractor fails to complete the correction of all Stormwater Deficiencies listed on the MoDOT Inspection Report within the specified time limit, the Commission will be damaged in various ways, including but not limited to, potential liability, required mitigation, environmental clean-up, fines, and penalties. These damages are not reasonably capable of being computed or quantified. Therefore, the contractor will be charged with liquidated damages specified in the amount of \$2,000 per day for failure to correct one or more of the Stormwater Deficiencies listed on the Inspection Report within the specified time limit. In addition to the stipulated damages, the stoppage of work shall remain in effect until all corrections are complete.

6.0 Basis of Payment. No direct payment will be made for compliance with this provision.

- **Delete Sec 106.9 in its entirety and substitute the following:**

106.9 Buy America Requirements.

Buy America Requirements are waived if the total amount of Federal financial assistance applied to the project, through awards or subawards, is below \$500,000.

106.9.1 Buy America Requirements for Iron and Steel.

On all federal-aid projects, the contractor's attention is directed to Title 23 CFR 635.410 *Buy America Requirements*. Where steel or iron products are to be permanently incorporated into the contract work, steel and iron material shall be manufactured, from the initial melting stage through the application of coatings, in the USA except for "minimal use" as described herein. Furthermore,

any coating process of the steel or iron shall be performed in the USA. Under a general waiver from FHWA the use of pig iron and processed, pelletized, and reduced iron ore manufactured outside of the USA will be permitted in the domestic manufacturing process for steel or iron material.

106.9.1.1 Buy America Requirements for Iron and Steel for Manufactured items.

A manufactured item will be considered iron and steel if it is “predominantly” iron or steel. Predominantly iron or steel means that the cost of iron or steel content of a product is more than 50 percent of the total cost of all its components.

106.9.2 Any sources other than the USA as defined will be considered foreign. The required domestic manufacturing process shall include formation of ingots and any subsequent process. Coatings shall include any surface finish that protects or adds value to the product.

106.9.3 “Minimal use” of foreign steel, iron or coating processes will be permitted, provided the cost of such products does not exceed 1/10 of one percent (0.1 percent) of the total contract cost or \$2,500.00, whichever is greater. If foreign steel, iron, or coating processes are used, invoices to document the cost of the foreign portion, as delivered to the project, shall be provided and the engineer’s written approval obtained prior to placing the material in any work.

106.9.4 Buy America requirements include a step certification for all fabrication processes of all steel or iron materials that are accepted per Sec 1000. The AASHTO Product Evaluation and Audit Solutions compliance program verifies that all steel and iron products fabrication processes conform to 23 CFR 635.410 Buy America Requirements and is an acceptable standard per 23 CFR 635.410(d). AASHTO Product Evaluation and Audit Solutions compliant suppliers will not be required to submit step certification documentation with the shipment for some selected steel and iron materials. The AASHTO Product Evaluation and Audit Solutions compliant supplier shall maintain the step certification documentation on file and shall provide this documentation to the engineer upon request.

106.9.4.1 Items designated as Category 1 will consist of steel girders, piling, and reinforcing steel installed on site. Category 1 items require supporting documentation prior to incorporation into the project showing all steps of manufacturing, including coating, as being completed in the United States and in accordance with CFR Title 23 Section 635.410 Buy America Requirements. This includes the Mill Test Report from the original producing steel mill and certifications documenting the manufacturing process for all subsequent fabrication, including coatings. The certification shall include language that certifies the following. That all steel and iron materials permanently incorporated in this project was procured and processed domestically and all manufacturing processes, including coating, as being completed in the United States and in accordance with CFR Title 23 Section 635.410.

106.9.4.2 Items designated as Category 2 will include all other steel or iron products not in Category 1 and permanently incorporated in the project. Category 2 items shall consist of, but not be limited to items such as fencing, guardrail, signing, lighting and signal supports. The prime contractor is required to submit a material of origin form certification prior to incorporation into the project from the fabricator for each item that the product is domestic. The Certificate of Materials Origin form ([link to certificate form](#)) from the fabricator must show all steps of manufacturing, including coating, as being completed in the United States and in accordance with CFR Title 23 Section 635.410 Buy America Requirements and be signed by a fabricator representative. The engineer reserves the right to request additional information and documentation to verify that all Buy America requirements have been satisfied. These documents shall be submitted upon

request by the engineer and retained for a period of 3 years after the last reimbursement of the material.

106.9.4.3 Any minor miscellaneous steel or iron items that are not included in the materials specifications shall be certified by the prime contractor as being procured domestically. Examples of these items would be bolts for sign posts, anchorage inserts, etc. The certification shall read "I certify that all steel and iron materials permanently incorporated in this project during all manufacturing processes, including coating, as being completed in the United States and in accordance with CFR Title 23 Section 635.410 Buy America Requirements procured and processed domestically in accordance with CFR Title 23 Section 635.410 Buy America Requirements. Any foreign steel used was submitted and accepted under minor usage". The certification shall be signed by an authorized representative of the prime contractor.

106.9.5 When permitted in the contract, alternate bids may be submitted for foreign steel and iron products. The award of the contract when alternate bids are permitted will be based on the lowest total bid of the contract based on furnishing domestic steel or iron products or 125 percent of the lowest total bid based on furnishing foreign steel or iron products. If foreign steel or iron products are awarded in the contract, domestic steel or iron products may be used; however, payment will be at the contract unit price for foreign steel or iron products.

106.9.6 Buy America Requirements for Construction Materials other than iron and steel materials. Construction materials means articles, materials, or supplies that consist of only one of the items listed. Minor additions of articles, materials, supplies, or binding agents to a construction material do not change the categorization of the construction material. Upon request by the engineer, the contractor shall submit a domestic certification for all construction materials listed that are incorporated into the project.

- (a) Non-ferrous metals
- (b) Plastic and Polymer-based products (including polyvinylchloride, composite building materials, and polymers used in fiber optic cables)
- (c) Glass (including optic glass)
- (d) Fiber optic cable (including drop cable)
- (e) Optical fiber
- (f) Lumber
- (g) Engineered wood
- (h) Drywall

106.9.6.1 Minimal Use allowance for Construction Materials other than iron or steel.

"The total value of the non-compliant products is no more than the lesser of \$1,000,000 or 5% of total applicable costs for the project." The contractor shall submit to the engineer any non-domestic materials and their total material cost to the engineer. The contractor and the engineer will both track these totals to assure that the minimal usage allowance is not exceeded.

106.9.7 Buy America Requirements for Manufactured Products.

Manufactured products means:

- (a) Articles, materials, or supplies that have been:
 - (i) Processed into a specific form and shape; or
 - (ii) Combined with other articles, materials, or supplies to create a product with different properties than the individual articles, materials, or supplies.

- (b) If an item is classified as an iron or steel product, a construction material, or a section 70917(c) material under § 184.4(e) and the definitions set forth in this section, then it is not a manufactured product. However, an article, material, or supply classified as a manufactured product under § 184.4(e) and paragraph (1) of this definition may include components that are construction materials, iron or steel products, or section 70917(c) materials.

106.9.7.1 Manufactured products are exempt from Buy America requirements. To qualify as a manufactured product, items that consist of two or more of the listed construction materials that have been combined together through a manufacturing process, and items that include at least one of the listed materials combined with a material that is not listed through a manufacturing process, should be treated as manufactured products, rather than as construction materials.

106.9.7.2 Manufactured items are covered under a general waiver to exclude them from Buy America Requirements. To qualify for the exemption the components must comprise of 55% of the value of materials in the item. The final assembly must also be performed domestically.

- Pavement Marking Paint Requirements for Standard Waterborne and Temporary

1.0 Description. High Build acrylic waterborne pavement marking paint shall be used in lieu of standard acrylic waterborne pavement marking paint for all Standard Waterborne Pavement Marking Paint items and all Temporary Pavement Marking Paint items. Paint thickness, bead type, bead application rate, retroreflectivity requirements, and all other specifications shall remain as stated in the Missouri Standard Specifications for Highway Construction, except as otherwise amended in the contract documents.

2.0 Material Requirements. Material requirements for Sec 620.20.2.5 Standard Waterborne Paint, and Sec 620.10.2 Temporary Pavement Marking Paint shall be per Sec 1048.20.1.2 High Build Acrylic Waterborne Pavement Marking Paint.

- Third-Party Test Waiver for Concrete Aggregate

1.0 Description. Third party tests may be allowed for determining the durability factor for concrete pavement and concrete masonry aggregate.

2.0 Material. All aggregate for concrete shall be in accordance with Sec 1005.

2.1 MoDOT personnel shall be present at the time of sampling at the quarry. The aggregate sample shall be placed in an approved tamper-evident container (provided by the quarry) for shipment to the third-party testing facility.

2.2 AASHTO T 161 Method B Resistance of Concrete to Rapid Freezing and Thawing, shall be used to determine the aggregate durability factor. All concrete beams for testing shall be 3-inch wide by 4-inch deep by 16-inch long or 3.5-inch wide by 4.5-inch deep by 16-inch long. All beams for testing shall receive a 35-day wet cure fully immersed in saturated lime water prior to initiating the testing process.

2.3 Concrete test beams shall be made using a MoDOT approved concrete pavement mix design.

3.0 Testing Facility Requirements. All third-party test facilities shall meet the requirements outlined in this provision.

3.1 The testing facility shall be AASHTO accredited.

3.1.1 For tests ran after January 1, 2025, accreditation documentation shall be on file with the Construction and Materials Division prior to any tests being performed.

3.1.2 Construction and Materials Division may consider tests completed prior to January 1, 2025, to be acceptable if all sections of this provision are met, with the exception of 3.1.1. Accreditation documentation shall be provided with the test results for tests completed prior to January 1, 2025. No tests completed prior to September 1, 2024, will be accepted.

3.2 The testing facility shall provide their testing process, list of equipment, equipment calibration documentation, and testing certifications or qualifications of technicians performing the AASHTO T 161 Procedure B tests. The testing facility shall provide details on their freezing and thawing apparatus including the time and temperature profile of their freeze-thaw chamber. The profile shall include the temperature set points throughout the entirety of the freeze-thaw cycle. The profile shall show the cycle time at which the apparatus drains/fills with water and the cycle time at which the apparatus begins cooling the specimens.

3.3 Results, no more than five years old, from the third-party test facility shall compare within ± 2.0 percent of an independent test from another AASHTO accredited test facility or with MoDOT test records, in order to be approved for use (e.g. test facility results in a durability factor of 79, MoDOT's recent durability test factor is 81; this compared within +2 percent). The independent testing facility shall be in accordance with this provision. The comparison test can be from a different sample of the same ledge combination.

3.4 When there is a dispute between the third party durability test results and MoDOT durability test results, the MoDOT durability test result shall govern.

3.5 Test results shall be submitted to MoDOT's Construction and Materials division electronically for final approval. Test results shall include raw data for all measurements of relative modulus of elasticity and percent length change for each individual concrete specimen. Raw data shall include initial measurements made at zero cycles and every subsequent measurement of concrete specimens. Raw data shall include the cycle count and date each measurement was taken. Test results shall also include properties of the concrete mixture as required by AASHTO T 161. This shall include the gradation of the coarse aggregate sample. If AASHTO T 152 is used to measure fresh air content, then the aggregate correction factor for the mix determined in accordance with AASHTO T 152 shall also be included.

4.0 Method of Measurement. There is no method of measurement for this provision. The testing requirements and number of specimens shall be in accordance with AASHTO T 161 Procedure B.

5.0 Basis of Payment. No direct payment will be made to the contractor or quarry to recover the cost of aggregate samples, sample shipments, testing equipment, labor to prepare samples or test samples, or developing the durability report.

- **Delete paragraph 15.0 of the General Provision Disadvantaged Business Enterprise (DBE) Program Requirements and substitute the following:**

15.0 Bidder's List Quote Summary. MoDOT is a recipient of federal funds and is required by 49 CFR 26.11 to provide data about its DBE program. All bidders who seek to work on federally assisted contracts must submit data about all DBE and non-DBEs in accordance with Sec 102.7.9. MoDOT will not compare the submitted Bidder's List Quote Summary to any other documents or submittals, pre or post award. All information will be used by MoDOT in accordance with 49 CFR 26.11 for reporting to USDOT and to aid in overall DBE goal setting.

- **Add Sec 102.7.9 to include the following:**

102.7.9 Bidder's List Quote Summary. Each bidder shall submit with each bid a summary of all subcontractors, suppliers, manufacturers, and truckers considered on federally funded projects pursuant to 49 CFR 26.11. The bidder will provide the firm's name, the corresponding North American Industry Classification System (NAICS) code(s) the firm(s) were considered for, and whether or not they were used in the bid. The information submitted should be the most complete information available at the time of bid. The information shall be disclosed on the Bidder's List Quote Summary form provided in the bidding documents and submitted in accordance with Sec 102.10. Failure to disclose this information may result in a bid being declared irregular.

G. Utilities JSP-93-26F

1.0 For informational purposes only, the following is a list of names, addresses, and telephone numbers of the known utility companies in the area of the construction work for this improvement:

<u>Utility Name</u>	<u>Known Required Adjustment</u>	<u>Type</u>
AT&T Distribution Ken Lovette 600 W Pine Poplar Bluff, MO 63901 Phone: 573-686-1152 Mobile: 573-300-0490 Email: kl6298@att.com	Yes Section 2.1	Communications
Pemiscot Dunklin Electric Co. Andy 1240 Riggs St Kennett, MO 63857 Phone: 573-757-6641 Email: andy@pdec.coop	Yes Section 2.2	Fiber & Electric

1.1 The existence and approximate location of utility facilities known to exist, as shown on the plans, are based upon the best information available to the Owner at this time. This information is provided by the Owner "as-is" and the Owner expressly disclaims any representation or warranty as to the completeness, accuracy, or suitability of the information for any use. Reliance upon this information is done at the risk and peril of the user, and the Owner shall not be liable for any damages that may arise from any error in the information. It is, therefore, the responsibility of the contractor to verify the above listing information indicating existence, location and status of any facility. Such verification includes direct contact with the listed utilities.

2.0 Project Specific Provisions:

2.1 AT&T Distribution - Has copper cable located along the southern portion of the project limits. Cable will be cut and retired. Contact Ken Lovette four (4) weeks prior to start of construction.

2.2 Pemiscot Dunklin Electric Co. – has overhead electric located along northern and southern portion of the project limits. No adjustments anticipated. The contractor shall contact Andy, with PDEC, regarding any questions or shielding. PDEC has fiber located along the southern portion of the project limits. The existing fiber will be relocated. Contact JT four (4) weeks prior to start of construction.

H. Restrictions for Migratory Birds NJSP-16-06A

1.0 Description. Swallows or other bird species protected by the Migratory Bird Treaty Act may be nesting under the bridge or bridges that will be repaired under this contract.

2.0 Restrictions. To comply with the Migratory Bird Treaty Act, nests of protected species cannot be disturbed when active (eggs or young are present). Generally, nests are active between April 1 and July 31, but active nests can be present outside of these dates.

3.0 Avoidance Measures. The contractor shall not disturb active nests or destroy adults, eggs or young birds. In an effort to comply with the Migratory Bird Treaty Act, the contractor operations will be limited to the options established in the following sections.

3.1 Inactive or Partially Constructed Nests. If nests are present and MoDOT determines that the nests are inactive or partially constructed, the contractor may remove the nests provided that the colony's inactive or partially constructed nests are completely removed by March 15 and the contractor maintains a nest free condition until the bridge work is complete. Dry removal methods shall be used when practicable. If dry removal is not practicable, hydro cleaning may be used if approved by the Engineer and only if water is free of blasting grit, chemicals, or detergents, and applied using pressure less than 5,000 PSI. Clean water such as that from municipal water treatment plants or wells shall be used. Use of source water from Waters of the State (i.e., streams or lakes), is allowable, if the appropriate methods to prevent the possible spread of invasive aquatic species are implemented.

3.2 Water and Equipment Used for Hydro cleaning. Aquatic invasives such as zebra mussels and some algae species have infested several bodies of water in the United States and can be transported by vessels (barges, boats, tugs, tankers, etc.) and equipment (tanks, tubing, pumps, etc.) that have been used in areas that contain these invasive species. If equipment is not properly inspected and treated to prevent the spread of invasives, these species can be

introduced into areas not currently known to have a population. These invasive species are detrimental to existing ecosystems and can outcompete native species. To assist in preventing the introduction and spread of aquatic invasive species through MoDOT projects in Missouri streams and lakes, the following precautions shall be followed.

3.2.1 Use of Water from Streams, Lakes or Ponds. Contractors shall not use water for nest removal from streams, lakes or ponds, unless they have implemented appropriate methods to prevent the possible spread of invasive aquatic species. Water sources from municipal water treatment plants or wells may be used without following these measures provided the equipment to be used has not previously contained waters from streams, lakes or ponds. If the equipment has previously contained waters from other streams or lakes, the following measures must be implemented prior to use.

3.2.1.1 Equipment Washing. Prior to the use or re-use of equipment following any use with water from streams, lakes or ponds, all equipment shall be washed and rinsed thoroughly with hard spray (power wash) and hot (minimum 120° F) water, for at least one minute.

3.2.1.2 Equipment Treating or Drying. Equipment shall be treated or dried in one of the following manners.

3.2.1.2.1 Equipment interior and/or other surfaces shall be treated with a 10% bleach solution to kill any aquatic nuisance species. This solution must also be run through all intake lines and hoses, to sterilize interior components. When chlorine treatment is used, all chlorine runoff from equipment washing must be collected and properly treated and/or disposed of in accordance with Sec 806.

3.2.1.2.2 Equipment interior and/or other surfaces shall be treated with 140° F water for a minimum of 10 seconds contact on all surfaces. 140 ° F water must also be run through all intake lines and hoses, to purge any standing water.

3.2.1.2.3 Equipment shall be flushed of all non-municipal water, and dried thoroughly, in the sun before using in or transporting between streams and lakes. Dry times will depend on the season the equipment is being used. Equipment must dry a minimum of 7 days for June-September, 18 days for March-May; 18 days for October-November, and 30 days for December-February. The drying method should be reserved as a last resort option.

3.2.2 Prior to use of equipment, contractors shall provide the MoDOT inspector written documentation of the equipment's geographic origin (including the water body it was last used in), as well as defining the specified treatment method used to adequately ensure protection against invasive species. The written documentation will include a statement indicating the contractor is aware of these provisions and will also treat the equipment appropriately after completion of the project.

3.3 Active Nests. The contractor may work on the bridge if active nests are present, as long as the work does not impact or disturb the birds and/or nests. At a minimum, work shall not be performed within 10 feet of an active nest; however, the contractor is responsible for ensuring their activities do not impact the nests, eggs, or young.

4.0 Additional Responsibilities. If active bird nests remain after all reasonable avoidance measures have been taken, or if bird nests are observed during project construction, the

contractor shall notify the Resident Engineer and contact the MoDOT Environmental Section (573-526-4778) to determine if there are other allowable options.

I. Liquidated Damages for Winter Months JSP-04-17A

Delete Sec 108.8.1.3 (a)

Liquidated damages for failure to complete the work on time shall not be waived from December 15 to March 15, both dates inclusive.

J. Contractor Quality Control NJSP-15-42

1.0 The contractor shall perform Quality Control (QC) testing in accordance with the specifications and as specified herein. The contractor shall submit a Quality Control Plan (QC Plan) to the engineer for approval that includes all items listed in Section 2.0, prior to beginning work.

2.0 Quality Control Plan.

- (a) The name and contact information of the person in responsible charge of the QC testing.
- (b) A list of the QC technicians who will perform testing on the project, including the fields in which they are certified to perform testing.
- (c) A proposed independent third party testing firm for dispute resolution, including all contact information.
- (d) A list of Hold Points, when specified by the engineer.
- (e) The MoDOT Standard Inspection and Testing Plan (ITP). This shall be the version that is posted at the time of bid on the MoDOT website (www.modot.org/quality).

3.0 Quality Control Testing and Reporting. Testing shall be performed per the test method and frequency specified in the ITP. All personnel who perform sampling or testing shall be certified in the MoDOT Technician Certification Program for each test that they perform.

3.1 Reporting of Test Results. All QC test reports shall be submitted as soon as practical, but no later than the day following the test. Test data shall be immediately provided to the engineer upon request at any time, including prior to the submission of the test report. No payment will be made for the work performed until acceptable QC test results have been received by the engineer and confirmed by QA test results.

3.1.1 Test results shall be reported on electronic forms provided by MoDOT. Forms and Contractor Reporting Excel2Oracle Reports (CRE2O) can be found on the MoDOT website. All required forms, reports and material certifications shall be uploaded to a Microsoft SharePoint® site provided by MoDOT, and organized in the file structure established by MoDOT.

3.2 Non-Conformance Reporting. A Non-Conformance Report (NCR) shall be submitted by the contractor when the contractor proposes to incorporate material into the work that does not meet the testing requirements or for any work that does not comply with the contract terms or specifications.

3.2.1 Non-Conformance Reporting shall be submitted electronically on the Non-Conformance Report form provided on the MoDOT Website. The NCR shall be uploaded to the MoDOT SharePoint® site and an email notification sent to the engineer.

3.2.2 The contractor shall propose a resolution to the non-conforming material or work. Acceptance of a resolution by the engineer is required before closure of the non-conformance report.

4.0 Work Planning and Scheduling.

4.1 Two-week Schedule. Each week, the contractor shall submit to the engineer a schedule that outlines the planned project activities for the following two-week period. The two-week schedule shall detail all work and traffic control events planned for that period and any Hold Points specified by the engineer.

4.2 Weekly Meeting. When work is active, the contractor shall hold a weekly project meeting with the engineer to review the planned activities for the following week and to resolve any outstanding issues. Attendees shall include the engineer, the contractor superintendent or project manager and any foreman leading major activities. This meeting may be waived when, in the opinion of the engineer, a meeting is not necessary. Attendees may join the meeting in person, by phone or video conference.

4.3 Pre-Activity Meeting. A pre-activity meeting is required in advance of the start of each new activity, except when waived by the engineer. The purpose of this meeting is to review construction details of the new activity. At a minimum, the discussion topics shall include: safety precautions, QC testing, traffic impacts, and any required Hold Points. Attendees shall include the engineer, the contractor superintendent and the foreman who will be leading the new activity. Pre-activity meetings may be held in conjunction with the weekly project meeting.

4.4 Hold Points. Hold Points are events that require approval by the engineer prior to continuation of work. Hold Points occur at definable stages of work when, in the opinion of the engineer, a review of the preceding work is necessary before continuation to the next stage.

4.4.1 A list of typical Hold Point events is available on the MoDOT website. Use of the Hold Point process will only be required for the project-specific list of Hold Points, if any, that the engineer submits to the contractor in advance of the work. The engineer may make changes to the Hold Point list at any time.

4.4.2 Prior to all Hold Point inspections, the contractor shall verify the work has been completed in accordance with the contract and specifications. If the engineer identifies any corrective actions needed during a Hold Point inspection, the corrections shall be completed prior to continuing work. The engineer may require a new Hold Point to be scheduled if the corrections require a follow-up inspection. Re-scheduling of Hold Points require a minimum 24-hour advance notification from the contractor unless otherwise allowed by the engineer.

5.0 Quality Assurance Testing and Inspection. MoDOT will perform quality assurance testing and inspection of the work, except as specified herein. The contractor shall utilize the inspection checklists provided in the ITP as a guide to minimize findings by MoDOT inspection staff. Submittal of completed checklists is not required, except as specified in 5.1.

5.1 Inspection and testing required in the production of concrete for the project shall be the responsibility of the contractor. Submittal of the 501 Concrete Plant Checklist is required.

6.0 Basis of Payment. No direct payment will be made for compliance with this provision.

K. Modified Linear Grading Class 2

1.0 Description. Modified Linear Grading, Class 2, shall consist of contractor-furnished fill, embankment construction, excavating and grading existing shoulders to facilitate placement of pavement and base, grading of ditches and slopes, and final shaping necessary to conform to the lines and grades in the plans, and shall conform to all applicable portions of Sec 207 and specifically as follows.

2.0 Construction Requirements.

2.1 It may be necessary to go outside the limits of the right of way to obtain additional material. All contractor furnished material shall be approved by the Engineer prior to being incorporated into the project.

2.2 The Engineer shall have sole discretion in determining whether excess material may be incorporated within right-of-way or must be disposed of outside of right-of-way.

2.3 All areas to be graded shall be cleared and grubbed in accordance with Sec 201 or as directed by the Engineer. No measurement or payment will be made for clearing and grubbing.

2.4 Roadside ditches shall be graded to match the existing flowline unless shown otherwise in the plans. Grading for pipe extensions shall match the projected flowline of the existing pipe.

2.5 Any damage to existing drainage structures or existing pavement, resulting from the Contractor's operations, shall be repaired at the Contractor's expense and to the satisfaction of the Engineer.

3.0 Method of Measurement. Measurement will be made to the nearest 1/10 station for the length of grading measured along the centerline of the traveled way.

4.0 Basis of Payment. All costs incurred by the Contractor to comply with this provision shall be considered completely covered by the contract unit price for Item 207-99.09, Modified Linear Grading, Class 2. No direct payment will be made for contractor furnished material or disposal of excess material.

L. Damage to Existing Roadways and Entrances

1.0 Description. This work shall consist of repairing any damage to existing pavement, shoulders, side roads, and entrances caused by Contractor operations. This shall include, but is not limited to, damage caused by the traffic during Contractor operations within the project limits including the work zone signing.

2.0 Construction Requirements. Any cracking, gouging, or other damage to the existing pavement, shoulders, side roads, or entrances from general construction shall be repaired within

twenty-four (24) hours of the time of damage at the Contractor's expense. Repair of the damaged pavement, shoulders, side roads, or entrances shall be as determined by the Engineer.

3.0 Method of Measurement. No measurement of damaged pavement, shoulder, side roads, or entrances, as described above, shall be made.

4.0 Basis of Payment. No payment will be made for repairs to existing pavement, shoulders, side roads or entrances damaged by Contractor operations.

M. Temporary Stream Crossings and Workpads

1.0 Description. This work shall include construction of a temporary stream crossing or workpad to facilitate the placement of the Contractor's equipment in the stream, in accordance with Division 100 of the General Provisions, Section 806.1 of the Standard Specifications, and as follows.

2.0 Construction Requirements. The Contractor shall be solely responsible for the design, installation, maintenance, and removal of the temporary stream crossing or workpad, as well as any structures installed to maintain proper flow while the temporary crossing or workpad is in place.

2.1 Temporary crossings and workpads shall be constructed of clean rock fill in accordance with Sec 303.2, except Sec 303.2.3 shall not apply.

2.2 The Contractor shall design the temporary crossing or workpad, including the size and number of pipes, to maintain normal flows, prevent upstream flooding, and allow free movement of aquatic life in the stream.

2.3 Storm water from the approaches to temporary crossings or workpads must be diverted to appropriate erosion control devices to allow sediment-laden runoff to be treated prior to entering the stream.

2.4 Pipes shall be anchored to prevent being swept from the project during high flows.

2.5 Temporary stream crossings and workpads shall not conflict with existing utilities. Any utilities that conflict with the construction of a temporary crossing/workpad or operation of equipment on a temporary crossing/workpad shall be relocated at the Contractor's expense.

3.0 Basis of Payment. No direct payment will be made for any equipment, labor, material, or time involved with the design, installation, maintenance, or removal of temporary stream crossings and workpads. The contractor shall be responsible for all costs, including damage and penalties.

N. Airport Requirements JSP-15-09

1.0 Description. The project is located near a public use airport or heliport or is more than 200 feet above existing ground level, which requires adherence to Federal Aviation Regulation Part 77 (FAA Reg Part 77). "Near" to a public use airport or heliport is defined as follows:

- 20,000 feet (4 miles) from an airport with a runway length of at least 3,200 feet
- 10,000 feet (2 miles) from an airport with runway length less than 3,200 feet

5,000 feet (1 mile) from a public use heliport

2.0 The maximum height of the improvement and the equipment operating while performing the improvements was assumed to be no higher than the top of the existing power poles on each side of the current travelway during the process of evaluating the project for compliance with FAA Reg Part 77.

2.1 If the contractor's height of equipment or if the improvement itself is beyond the assumed height as indicated in Sec 2.0, the contractor will work with the resident engineer to fill out the Form 7460-1, or revise the original Form 7460-1 based upon the proposed height and resubmit, if necessary, for a determination by FAA on compliance with FAA Reg Part 77. Further information can be found in MoDOT's Engineering Policy Guide 235.8 Airports. If the Form 7460-1 must be filed, the associated work shall not be performed prior to the FAA determination, which could take up to 45 days.

2.2 If the contractor's height of equipment and the improvement itself is below the assumed height as indicated in Sec 2.0, no further action is necessary to fulfill the requirements set forth in FAA Reg Part 77.

3.0 **Basis of Payment.** There will be no direct payment for any work associated with this provision. Contract time extension will be given for the time necessary to obtain or revise the FAA permit. Any delays or costs incurred in obtaining the revised permit will be noncompensable.

O. **DBE Prompt Payment Reporting JSP-24-05B**

1.0 Description.

1.1 This provision will only apply to contracts that have a Disadvantaged Business Enterprise (DBE) goal greater than 0% and have at least one DBE subcontractor.

1.2 MoDOT monitors the payments made by prime contractors and subcontractors to DBEs for compliance with DBE payment monitoring rules as outlined in 49 CFR 26.37. To facilitate this monitoring, MoDOT requires prime contractors to report their remitted payments to DBEs and subcontractors to report their remitted payments to lower-tier DBEs.

1.3 Tracking of DBE payments are made through the Signet™ application (Signet). Signet is a third-party service, supported by the vendor, for usage by the prime contractor and all subcontractors. Signet is only a reporting tool; it does not process financial transactions. MoDOT does not provide direct technical support for Signet. Information about Signet may be found at <https://signet-help.zendesk.com/hc/en-us>.

1.4 Upon completion of the first pay estimate on the contract, Signet will automatically send an email to the prime contractor prompting registration. The prime will be required to pay a one-time, fixed fee of \$1,000 for this contract directly to the Signet vendor. Use of Signet to track DBE payments will be available for the life of the contract, regardless of the contract value, contract duration, number of subcontractors, or payments reported. No additional fee will be charged to subcontractors that are required to report payments or DBEs that are required to verify payments through Signet. The contractor may also, at no additional cost, report payments through Signet to subcontractors that are not DBEs.

1.5 After each estimate, when contractor reporting of payments is complete, the subcontractor will receive an email notifying them of the payment and requesting verification of the reported payment. A subcontractor that has not completed registration with Signet will be prompted to do so at this time.

1.6 Users will be set up automatically based on information in MoDOT's vendor list. Additional users under each contractor may be added once registration has been completed within Signet. The current vendor list can be found at <https://www.modot.org/bid-opening-info>.

1.7 For purposes of this requirement, payer is defined as the prime contractor or subcontractor that reports a payment in Signet to a vendor that is either a subcontractor, trucker, manufacturer, regular dealer, or broker. Payee is defined as the vendor that receives notification of payment through Signet from the prime contractor or a higher-tier subcontractor. Payment is defined as issuing an Electronic Funds Transfer (EFT) or mailing a check to a payee.

2.0 Requirements. Payers must report remitted payment to DBEs within Signet, for work performed by the DBE subcontractor, DBE trucking, materials supplied from a DBE manufacturer, dealer, or broker, as well as a return of retainage (and/or other amounts withheld), within 15 calendar days.

2.1 Prime contractors must report remitted payments to DBEs within 15 calendar days of each payment it receives from MoDOT. Prime contractors must also report payments to non-DBE subcontractors if that subcontractor is making payment to a lower tier DBE subcontractor, trucker, manufacturer, regular dealer, or broker.

2.2 The payer must report the following information within Signet:

- a. The name of the payee.
- b. The dollar amount of the payment to the payee.
- c. The date the payment was made.
- d. Any retainage or other amount withheld (if any) and the reason for the withholding (if other than retainage).
- e. The DBE function performed for this payment (e.g., contracting, trucking, or supplying as a manufacturer, dealer, or broker).
- f. Other information required by Signet.

The payer must report its return of retainage (and/or other amounts withheld) in separate, standalone payment entries (i.e., without being comingled with a payment for work performed or materials supplied).

2.3 In the event that no work has been completed by a DBE during the estimate period, such that no payment is due to a DBE subcontractor, trucker, manufacturer, regular dealer, or broker, then the prime contractor will mark payment complete within Signet, and no other payments are required to be reported.

2.4 Each subcontractor making a payment to a lower-tier DBE must report remitted payments within Signet, as detailed in Section 2.2, within 15 days of receipt of each payment from the prime contractor.

2.5 DBE payees must verify in Signet each payment reported by a payer within 15 calendar days of the payment being reported by the payer. This verification includes whether the payment was received, and if so, whether it was as expected.

3.0 Basis of Payment. A fixed cost of \$1,000 will be paid on this contract for the required software to report payments to DBEs through Signet. Regardless of the number of projects in a contract, a single payment will be made under item 108-10.00, SIGNET DBE REPORTING, per lump sum. The engineer reserves the right to underrun this item for any reason. Any additional costs for registration, software, usage, time, labor, or other costs will be considered incidental and no direct payment will be made.

P. Optional Pavements JSP 06-06H

1.0 Description. This work shall consist of a pavement composed of either Portland cement concrete or asphaltic concrete constructed on a prepared subgrade. This work shall be performed in accordance with the standard specifications and as shown on the plans or established by the engineer.

2.0 The quantities shown reflect the total square yards of pavement surface designated for each pavement type as computed and shown on the plans.

2.1 No additional payment will be made for asphaltic concrete mix quantities to construct the required 1:1 slope along the edge of the pavement, or for tack applied between lifts of asphalt.

2.2 No additional payment will be made for aggregate base quantities outside the limits of the final surface area as computed and shown on the plans. When A2 shoulders are specified, payment for aggregate base will be as shown on the plans.

2.3 The grading shown on the plans was designed for the thicker pavement option. For projects with grading in the contract, there will be no adjustment of the earthwork quantities due to adjusting the roadway subgrade for optional pavements.

2.4 The contractor shall comply with Sections 401 through 403 for the asphalt option and Sections 501 and 502 for the concrete option.

2.5 Pavement options composed of Portland cement concrete shall have contrast pavement marking for intermittent markings (skips), dotted lines, and solid intersection lane lines. The pavement markings shall be in accordance with Section 620. No additional payment will be made for the contrast pavement markings.

3.0 Method of Measurement. The quantities of concrete pavement will be measured in accordance with Section 502.14. The quantities of asphaltic concrete pavement will be measured in accordance with Section 403.22.

4.0 Basis of Payment. The accepted quantity of the chosen option will be paid for at the contract unit bid price for Item 403-99.05, Optional Pavement, per square yard.

4.1 For projects with previously graded roadbeds, any additional quantities required to bring the roadway subgrade to the proper elevation will be considered completely covered by the pay item for Subgrading and Shouldering.

Job No.: JSE0101

Route: N

County: Dunklin

4.2 Price Adjustment for Fuel. If the contractor accepts the option for fuel adjustment in the bid proposal, a fuel adjustment will be applied in accordance with Sec 109.14 for the type of pavement constructed.

Job No.: JSE0104
 Route: B
 County: Pemiscot

JOB SPECIAL PROVISIONS TABLE OF CONTENTS (ROADWAY)

(Job Special Provisions shall prevail over General Special Provisions whenever in conflict therewith.)

A.	General - Federal JSP-09-02K	1
B.	Contract Liquidated Damages JSP-13-01D	1
C.	Work Zone Traffic Management JSP-02-06N	2
D.	Emergency Provisions and Incident Management JSP-90-11A	4
E.	Project Contact for Contractor/Bidder Questions JSP-96-05	5
F.	Supplemental Revisions JSP-18-01FF	5
G.	Utilities JSP-93-26F	12
H.	Restrictions for Migratory Birds NJSP-16-06A	14
I.	Liquidated Damages for Winter Months JSP-04-17A	15
J.	Contractor Quality Control NJSP-15-42	16
K.	Modified Linear Grading Class 2	17
L.	Damage to Existing Roadways and Entrances	18
M.	Temporary Stream Crossings and Workpads	19
N.	DBE Prompt Payment Reporting JSP-24-05B	19
O.	Optional Pavements JSP 06-06H	21
P.	Flap Gate	22

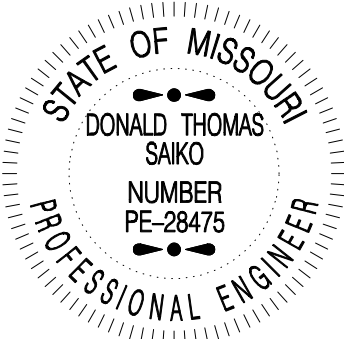
 <p>THIS SHEET HAS BEEN SIGNED, SEALED AND DATED ELECTRONICALLY.</p>	<p>MISSOURI HIGHWAYS AND TRANSPORTATION COMMISSION 105 W. CAPITOL AVE. JEFFERSON CITY, MO 65102 Phone 1-888-275-6636</p>
	<p>GARVER 7509 NW Tiffany Springs Parkway, STE 200</p>
	<p>Certificate of Authority: 2008013090 Consultant Phone: 816-298-6465</p>
	<p>If a seal is present on this sheet, JSP's have been electronically sealed and dated.</p>
	<p>JOB NUMBER: JSE0104 PEMISCOT COUNTY, MO DATE PREPARED: 7/15/2024</p>
<p>ADDENDUM DATE:</p>	
<p>Only the following items of the Job Special Provisions (Roadway) are authenticated by this seal: All</p>	

JOB
SPECIAL PROVISION

A. General - Federal JSP-09-02K

1.0 Description. The Federal Government is participating in the cost of construction of this project. All applicable Federal laws, and the regulations made pursuant to such laws, shall be observed by the contractor, and the work will be subject to the inspection of the appropriate Federal Agency in the same manner as provided in Sec 105.10 of the Missouri Standard Specifications for Highway Construction with all revisions applicable to this bid and contract.

1.1 This contract requires payment of the prevailing hourly rate of wages for each craft or type of work required to execute the contract as determined by the Missouri Department of Labor and Industrial Relations and requires adherence to a schedule of minimum wages as determined by the United States Department of Labor. For work performed anywhere on this project, the contractor and the contractor's subcontractors shall pay the higher of these two applicable wage rates. State Wage Rates, Information on the Required Federal Aid Provisions, and the current Federal Wage Rates are available on the Missouri Department of Transportation web page at www.modot.org under "Doing Business with MoDOT", "Contractor Resources". Effective Wage Rates will be posted 10 days prior to the applicable bid opening. These supplemental bidding documents have important legal consequences. It shall be conclusively presumed that they are in the bidder's possession, and they have been reviewed and used by the bidder in the preparation of any bid submitted on this project.

1.2 The following documents are available on the Missouri Department of Transportation web page at www.modot.org under "Doing Business with MoDOT"; "Standards and Specifications". The effective version shall be determined by the letting date of the project.

General Provisions & Supplemental Specifications

Supplemental Plans to July 2024 Missouri Standard Plans
For Highway Construction

These supplemental bidding documents contain all current revisions to the published versions and have important legal consequences. It shall be conclusively presumed that they are in the bidder's possession, and they have been reviewed and used by the bidder in the preparation of any bid submitted on this project.

B. Contract Liquidated Damages JSP-13-01D

1.0 Description. Liquidated Damages for failure or delay in completing the work on time for this contract shall be in accordance with Sec 108.8. The liquidated damages include separate amounts for road user costs and contract administrative costs incurred by the Commission.

2.0 Period of Performance. Prosecution of work is expected to begin on the date specified below in accordance with Sec 108.2. Regardless of when the work is begun on this contract, all work shall be completed on or before the date specified below. Completion by this date shall be in accordance with the requirements of Sec 108.7.1.

Notice to Proceed: June 9, 2025
Completion Date: November 1, 2026

2.1 Calendar Days. The count of calendar days will begin on the date the contractor starts any construction operations on the project.

Job Number	Calendar Days	Daily Road User Cost
JSE0104	107	\$1,800

3.0 Liquidated Damages for Contract Administrative Costs. Should the contractor fail to complete the work on or before the completion date specified in Section 2.0, or within the number of calendar days specified in Section 2.1, whichever occurs first, the contractor will be charged contract administrative liquidated damages in accordance with Sec 108.8 in the amount of **\$1,500** per calendar day for each calendar day, or partial day thereof, that the work is not fully completed. For projects in combination, these damages will be charged in full for failure to complete one or more projects within the above specified completion date or calendar days.

4.0 Liquidated Damages for Road User Costs. Should the contractor fail to complete the work on or before the completion date specified in Section 2.0, or within the number of calendar days specified in Section 2.1, whichever occurs first, the contractor will be charged road user costs in accordance with Sec 108.8 in the amount specified in Section 2.1 for each calendar day, or partial day thereof, that the work is not fully completed. These damages are in addition to the contract administrative damages and any other damages as specified elsewhere in this contract.

C. Work Zone Traffic Management JSP-02-06N

1.0 Description. Work zone traffic management shall be in accordance with applicable portions of Division 100 and Division 600 of the Standard Specifications, and specifically as follows.

1.1 Maintaining Work Zones and Work Zone Reviews. The Work Zone Specialist (WZS) shall maintain work zones in accordance with Sec 616.3.3 and as further stated herein. The WZS shall coordinate and implement any changes approved by the engineer. The WZS shall ensure all traffic control devices are maintained in accordance with Sec 616, the work zone is operated within the hours specified by the engineer, and will not deviate from the specified hours without prior approval of the engineer. The WZS is responsible to manage work zone delay in accordance with these project provisions. When requested by the engineer, the WZS shall submit a weekly report that includes a review of work zone operations for the week. The report shall identify any problems encountered and corrective actions taken. Work zones are subject to unannounced inspections by the engineer and other departmental staff to corroborate the validity of the WZS's review and may require immediate corrective measures and/or additional work zone monitoring.

1.2 Work Zone Deficiencies. Failure to make corrections on time may result in the engineer suspending work. The suspension will be non-excusable and non-compensable regardless if road user costs are being charged for closures.

2.0 Traffic Management Schedule.

2.1 Traffic management schedules shall be submitted to the engineer for review prior to the start of work and prior to any revisions to the traffic management schedule. The traffic management schedule shall include the proposed traffic control measures, the hours traffic control will be in place, and work hours.

2.2 The traffic management schedule shall conform to the limitations specified in Sec 616 regarding lane closures, traffic shifts, road closures and other width, height and weight restrictions.

2.3 The engineer shall be notified as soon as practical of any postponement due to weather, material or other circumstances.

2.4 In order to ensure minimal traffic interference, the contractor shall schedule lane closures for the absolute minimum amount of time required to complete the work. Lanes shall not be closed until material is available for continuous construction and the contractor is prepared to diligently pursue the work until the closed lane is opened to traffic.

3.0 Work Hour Restrictions.

3.1 Except for emergency work, as determined by the engineer, and long term lane closures required by project phasing, all lanes shall be scheduled to be open to traffic during the five major holiday periods shown below, from 12:00 noon on the last working day preceding the holiday until 6:00 a.m. on the first working day subsequent to the holiday unless otherwise approved by the engineer.

- Memorial Day
- Labor Day
- Thanksgiving
- Christmas
- New Year's Day

3.1.1 Independence Day. The lane restrictions specified in Section 3.1 shall also apply to Independence Day, except that the restricted periods shall be as follows:

When Independence Day falls on:	The Holiday is Observed on:	Halt Lane Closures beginning at:	Allow Lane Closures to resume at:
Sunday	Monday	Noon on Friday	6:00 a.m. on Tuesday
Monday	Monday	Noon on Friday	6:00 a.m. on Tuesday
Tuesday	Tuesday	Noon on Monday	6:00 a.m. on Wednesday
Wednesday	Wednesday	Noon on Tuesday	6:00 a.m. on Thursday
Thursday	Thursday	Noon on Wednesday	6:00 a.m. on Friday
Friday	Friday	Noon on Thursday	6:00 a.m. on Monday
Saturday	Friday	Noon on Thursday	6:00 a.m. on Monday

3.2 The contractor shall not perform any construction operation on the roadway, roadbed or active lanes, including the hauling of material within the project limits, during restricted periods, holiday periods or other special events specified in the contract documents.

3.3 The contractor shall be aware that traffic volume data indicates construction operations on the roadbed between the following hours will likely result in traffic queues greater than 15 minutes. Based on this, the contractor's operations will be restricted accordingly unless it can be successfully demonstrated the operations can be performed without a 15 minute queue in traffic. It shall be the responsibility of the engineer to determine if the above work hours may be modified. Working hours for evenings, weekends and holidays will be determined by the engineer.

4.0 Detours and Lane Closures.

4.1 When a changeable message sign (CMS) is provided, the contractor shall use the CMS to notify motorists of future traffic disruption and possible traffic delays one week before traffic is shifted to a detour or prior to lane closures. The CMS shall be installed at a location as approved or directed by the engineer. If a CMS with Communication Interface is required, then the CMS shall be capable of communication prior to installation on right of way. All messages planned for use in the work zone shall be approved and authorized by the engineer or its designee prior to deployment. When permanent dynamic message signs (DMS) owned and operated by MoDOT are located near the project, they may also be used to provide warning and information for the work zone. Permanent DMS shall be operated by the TMC, and any messages planned for use on DMS shall be approved and authorized by the TMC at least 72 hours in advance of the work.

5.0 Basis of Payment. No direct payment will be made to the contractor to recover the cost of equipment, labor, materials, or time required to fulfill the above provisions, unless specified elsewhere in the contract document. All authorized changes in the traffic control plan shall be provided for as specified in Sec 616.

D. Emergency Provisions and Incident Management JSP-90-11A

1.0 The contractor shall have communication equipment on the construction site or immediate access to other communication systems to request assistance from law enforcement or other emergency agencies for incident management. In case of traffic accidents or the need for law enforcement to direct or restore traffic flow through the job site, the contractor shall notify law enforcement or other emergency agencies immediately as needed. The area engineer's office shall also be notified when the contractor requests emergency assistance.

2.0 In addition to the 911 emergency telephone number for ambulance, fire or law enforcement services, the following agencies may also be notified for accident or emergency situation within the project limits.

Missouri Highway Patrol, Troop E – (573) 840-9500		
Pemiscot County, MO		
Sheriff: 573-333-4101		

2.1 This list is not all inclusive. Notification of the need for wrecker or tow truck services will remain the responsibility of the appropriate law enforcement agency.

2.2 The contractor shall notify law enforcement and emergency agencies before the start of construction to request their cooperation and to provide coordination of services when emergencies arise during the construction at the project site. When the contractor completes this

notification with law enforcement and emergency agencies, a report shall be furnished to the engineer on the status of incident management.

3.0 No direct pay will be made to the contractor to recover the cost of the communication equipment, labor, materials or time required to fulfill the above provisions.

E. Project Contact for Contractor/Bidder Questions JSP-96-05

All questions concerning this project during the bidding process shall be forwarded to the project contact listed below.

Tim Pickett, Project Contact
Southeast District
2675 N Main
Sikeston, MO 63801

Telephone Number: 573-472-9003
Email: Timothy.Pickett@modot.mo.gov

All questions concerning the bid document preparation can be directed to the Central Office – Design at (573) 751-2876.

F. Supplemental Revisions JSP-18-01FF

- Compliance with [2 CFR 200.216 – Prohibition on Certain Telecommunications and Video Surveillance Services or Equipment](#).

The Missouri Highways and Transportation Commission shall not enter into a contract (or extend or renew a contract) using federal funds to procure or obtain equipment, services, or systems that uses covered telecommunications equipment or services as substantial or as critical technology as part of any system where the video surveillance and telecommunications equipment was produced by Huawei Technologies Company, ZTE Corporation, Hytera Communications Corporation, Hangzhou Hikvision Digital Technology Company, or Dahua Technology Company (or any subsidiary or affiliate of such entities).

- Stormwater Compliance Requirements

1.0 Description. This provision requires the contractor to provide a Water Pollution Control Manager (WPCM) for any project that includes land disturbance on the project site and the total area of land disturbance, both on the project site, and all Off-site support areas, is one (1) acre or more. Regardless of the area of Off-site disturbance, if no land disturbance occurs on the project site, these provisions do not apply. When a WPCM is required, all sections within this provision shall be applicable, including assessment of specified Liquidated Damages for failure to correct Stormwater Deficiencies, as specified herein. This provision is in addition to any other stormwater, environmental, and land disturbance requirements specified elsewhere in the contract.

1.1 Definitions. The project site is defined as all areas designated on the plans, including temporary and permanent easements. The project site is equivalent to the “permitted site”, as defined in MoDOT’s State Operating Permit. An Off-site area is defined as any location off the project site the contractor utilizes for a dedicated project support function, such as, but not limited to, staging area, plant site, borrow area, or waste area.

1.2 Reporting of Off-Site Land Disturbance. If the project includes any planned land disturbance on the project site, prior to the start of work, the contractor shall submit a written report to the engineer that discloses all Off-site support areas where land disturbance is planned, the total acreage of anticipated land disturbance on those sites, and the land disturbance permit number(s). Upon request by the engineer, the contractor shall submit a copy of its land disturbance permit(s) for Off-site locations. Based on the total acreage of land disturbance, both on and Off-site, the engineer shall determine if these Stormwater Compliance Requirements shall apply. The Contractor shall immediately report any changes to the planned area of Off-site land disturbance. The Contractor is responsible for obtaining its own separate land disturbance permit for Off-site areas.

2.0 Water Pollution Control Manager (WPCM). The Contractor shall designate a competent person to serve as the Water Pollution Control Manager (WPCM) for projects meeting the description in Section 1.0. The Contractor shall ensure the WPCM completes all duties listed in Section 2.1.

2.1 Duties of the WPCM:

- (a) Be familiar with the stormwater requirements including the current MoDOT State Operating Permit for construction stormwater discharges/land disturbance activities; MoDOT’s statewide Stormwater Pollution Prevention Plan (SWPPP); the Corps of Engineers Section 404 Permit, when applicable; the project specific SWPPP, the Project’s Erosion & Sediment Control Plan; all applicable special provisions, specifications, and standard drawings; and this provision;
- (b) Successfully complete the MoDOT Stormwater Training Course within the last 4 years. The MoDOT Stormwater Training is a free online course available at MoDOT.org;
- (c) Attend the Pre-Activity Meeting for Grading and Land Disturbance and all subsequent Weekly Meetings in which grading activities are discussed;
- (d) Oversee and ensure all work is performed in accordance with the Project-specific SWPPP and all updates thereto, or as designated by the engineer;
- (e) Review the project site for compliance with the Project SWPPP, as needed, from the start of any grading operations until final stabilization is achieved, and take necessary actions to correct any known deficiencies to prevent pollution of the waters of the state or adjacent property owners prior to the engineer’s weekly inspections;
- (f) Review and acknowledge receipt of each MoDOT Inspection Report (Land Disturbance Inspection Record) for the Project within forty eight (48) hours of receiving the report and ensure that all Stormwater Deficiencies noted on the report are corrected as soon as possible, but no later than stated in Section 5.0.

3.0 Pre-Activity Meeting for Grading/Land Disturbance and Required Hold Point. A Pre-Activity meeting for grading/land disturbance shall be held prior to the start of any land disturbance operations. No land disturbance operations shall commence prior to the Pre-Activity meeting except work necessary to install perimeter controls and entrances. Discussion items at the pre-activity meeting shall include a review of the Project SWPPP, the planned order of grading operations, proposed areas of initial disturbance, identification of all necessary BMPs that shall be installed prior to commencement of grading operations, and any issues relating to compliance with the Stormwater requirements that could arise in the course of construction activity at the project.

3.1 Hold Point. Following the pre-activity meeting for grading/land disturbance and subsequent installation of the initial BMPs identified at the pre-activity meeting, a Hold Point shall occur prior to the start of any land disturbance operations to allow the engineer and WPCM the time needed to perform an on-site review of the installation of the BMPs to ensure compliance with the SWPPP is met. Land disturbance operations shall not begin until authorization is given by the engineer.

4.0 Inspection Reports. Weekly and post run-off inspections will be performed by the engineer and each Inspection Report (Land Disturbance Inspection Record) will be entered into a web-based Stormwater Compliance database. The WPCM will be granted access to this database and shall promptly review all reports, including any noted deficiencies, and shall acknowledge receipt of the report as required in Section 2.1 (f.).

5.0 Stormwater Deficiency Corrections. All stormwater deficiencies identified in the Inspection Report shall be corrected by the contractor within 7 days of the inspection date or any extended period granted by the engineer when weather or field conditions prohibit the corrective work. If the contractor does not initiate corrective measures within 5 calendar days of the inspection date or any extended period granted by the engineer, all work shall cease on the project except for work to correct these deficiencies, unless otherwise allowed by the engineer. All impact costs related to this halting of work, including, but not limited to stand-by time for equipment, shall be borne by the Contractor. Work shall not resume until the engineer approves the corrective work.

5.1 Liquidated Damages. If the Contractor fails to complete the correction of all Stormwater Deficiencies listed on the MoDOT Inspection Report within the specified time limit, the Commission will be damaged in various ways, including but not limited to, potential liability, required mitigation, environmental clean-up, fines, and penalties. These damages are not reasonably capable of being computed or quantified. Therefore, the contractor will be charged with liquidated damages specified in the amount of \$2,000 per day for failure to correct one or more of the Stormwater Deficiencies listed on the Inspection Report within the specified time limit. In addition to the stipulated damages, the stoppage of work shall remain in effect until all corrections are complete.

6.0 Basis of Payment. No direct payment will be made for compliance with this provision.

- **Delete Sec 106.9 in its entirety and substitute the following:**

106.9 Buy America Requirements.

Buy America Requirements are waived if the total amount of Federal financial assistance applied to the project, through awards or subawards, is below \$500,000.

106.9.1 Buy America Requirements for Iron and Steel.

On all federal-aid projects, the contractor's attention is directed to Title 23 CFR 635.410 *Buy America Requirements*. Where steel or iron products are to be permanently incorporated into the contract work, steel and iron material shall be manufactured, from the initial melting stage through the application of coatings, in the USA except for "minimal use" as described herein. Furthermore, any coating process of the steel or iron shall be performed in the USA. Under a general waiver from FHWA the use of pig iron and processed, pelletized, and reduced iron ore manufactured outside of the USA will be permitted in the domestic manufacturing process for steel or iron material.

106.9.1.1 Buy America Requirements for Iron and Steel for Manufactured items.

A manufactured item will be considered iron and steel if it is "predominantly" iron or steel. Predominantly iron or steel means that the cost of iron or steel content of a product is more than 50 percent of the total cost of all its components.

106.9.2 Any sources other than the USA as defined will be considered foreign. The required domestic manufacturing process shall include formation of ingots and any subsequent process. Coatings shall include any surface finish that protects or adds value to the product.

106.9.3 "Minimal use" of foreign steel, iron or coating processes will be permitted, provided the cost of such products does not exceed 1/10 of one percent (0.1 percent) of the total contract cost or \$2,500.00, whichever is greater. If foreign steel, iron, or coating processes are used, invoices to document the cost of the foreign portion, as delivered to the project, shall be provided and the engineer's written approval obtained prior to placing the material in any work.

106.9.4 Buy America requirements include a step certification for all fabrication processes of all steel or iron materials that are accepted per Sec 1000. The AASHTO Product Evaluation and Audit Solutions compliance program verifies that all steel and iron products fabrication processes conform to 23 CFR 635.410 Buy America Requirements and is an acceptable standard per 23 CFR 635.410(d). AASHTO Product Evaluation and Audit Solutions compliant suppliers will not be required to submit step certification documentation with the shipment for some selected steel and iron materials. The AASHTO Product Evaluation and Audit Solutions compliant supplier shall maintain the step certification documentation on file and shall provide this documentation to the engineer upon request.

106.9.4.1 Items designated as Category 1 will consist of steel girders, piling, and reinforcing steel installed on site. Category 1 items require supporting documentation prior to incorporation into the project showing all steps of manufacturing, including coating, as being completed in the United States and in accordance with CFR Title 23 Section 635.410 Buy America Requirements. This includes the Mill Test Report from the original producing steel mill and certifications documenting the manufacturing process for all subsequent fabrication, including coatings. The certification shall include language that certifies the following. That all steel and iron materials permanently incorporated in this project was procured and processed domestically and all manufacturing processes, including coating, as being completed in the United States and in accordance with CFR Title 23 Section 635.410.

106.9.4.2 Items designated as Category 2 will include all other steel or iron products not in Category 1 and permanently incorporated in the project. Category 2 items shall consist of, but not be limited to items such as fencing, guardrail, signing, lighting and signal supports. The prime

contractor is required to submit a material of origin form certification prior to incorporation into the project from the fabricator for each item that the product is domestic. The Certificate of Materials Origin form ([link to certificate form](#)) from the fabricator must show all steps of manufacturing, including coating, as being completed in the United States and in accordance with CFR Title 23 Section 635.410 Buy America Requirements and be signed by a fabricator representative. The engineer reserves the right to request additional information and documentation to verify that all Buy America requirements have been satisfied. These documents shall be submitted upon request by the engineer and retained for a period of 3 years after the last reimbursement of the material.

106.9.4.3 Any minor miscellaneous steel or iron items that are not included in the materials specifications shall be certified by the prime contractor as being procured domestically. Examples of these items would be bolts for sign posts, anchorage inserts, etc. The certification shall read “I certify that all steel and iron materials permanently incorporated in this project during all manufacturing processes, including coating, as being completed in the United States and in accordance with CFR Title 23 Section 635.410 Buy America Requirements procured and processed domestically in accordance with CFR Title 23 Section 635.410 Buy America Requirements. Any foreign steel used was submitted and accepted under minor usage”. The certification shall be signed by an authorized representative of the prime contractor.

106.9.5 When permitted in the contract, alternate bids may be submitted for foreign steel and iron products. The award of the contract when alternate bids are permitted will be based on the lowest total bid of the contract based on furnishing domestic steel or iron products or 125 percent of the lowest total bid based on furnishing foreign steel or iron products. If foreign steel or iron products are awarded in the contract, domestic steel or iron products may be used; however, payment will be at the contract unit price for foreign steel or iron products.

106.9.6 Buy America Requirements for Construction Materials other than iron and steel materials. Construction materials means articles, materials, or supplies that consist of only one of the items listed. Minor additions of articles, materials, supplies, or binding agents to a construction material do not change the categorization of the construction material. Upon request by the engineer, the contractor shall submit a domestic certification for all construction materials listed that are incorporated into the project.

- (a) Non-ferrous metals
- (b) Plastic and Polymer-based products (including polyvinylchloride, composite building materials, and polymers used in fiber optic cables)
- (c) Glass (including optic glass)
- (d) Fiber optic cable (including drop cable)
- (e) Optical fiber
- (f) Lumber
- (g) Engineered wood
- (h) Drywall

106.9.6.1 Minimal Use allowance for Construction Materials other than iron or steel.

“The total value of the non-compliant products is no more than the lesser of \$1,000,000 or 5% of total applicable costs for the project.” The contractor shall submit to the engineer any non-domestic materials and their total material cost to the engineer. The contractor and the engineer will both track these totals to assure that the minimal usage allowance is not exceeded.

106.9.7 Buy America Requirements for Manufactured Products.

Manufactured products means:

- (a) Articles, materials, or supplies that have been:
 - (i) Processed into a specific form and shape; or
 - (ii) Combined with other articles, materials, or supplies to create a product with different properties than the individual articles, materials, or supplies.
- (b) If an item is classified as an iron or steel product, a construction material, or a section 70917(c) material under § 184.4(e) and the definitions set forth in this section, then it is not a manufactured product. However, an article, material, or supply classified as a manufactured product under § 184.4(e) and paragraph (1) of this definition may include components that are construction materials, iron or steel products, or section 70917(c) materials.

106.9.7.1 Manufactured products are exempt from Buy America requirements. To qualify as a manufactured product, items that consist of two or more of the listed construction materials that have been combined together through a manufacturing process, and items that include at least one of the listed materials combined with a material that is not listed through a manufacturing process, should be treated as manufactured products, rather than as construction materials.

106.9.7.2 Manufactured items are covered under a general waiver to exclude them from Buy America Requirements. To qualify for the exemption the components must comprise of 55% of the value of materials in the item. The final assembly must also be performed domestically.

- Pavement Marking Paint Requirements for Standard Waterborne and Temporary

1.0 Description. High Build acrylic waterborne pavement marking paint shall be used in lieu of standard acrylic waterborne pavement marking paint for all Standard Waterborne Pavement Marking Paint items and all Temporary Pavement Marking Paint items. Paint thickness, bead type, bead application rate, retroreflectivity requirements, and all other specifications shall remain as stated in the Missouri Standard Specifications for Highway Construction, except as otherwise amended in the contract documents.

2.0 Material Requirements. Material requirements for Sec 620.20.2.5 Standard Waterborne Paint, and Sec 620.10.2 Temporary Pavement Marking Paint shall be per Sec 1048.20.1.2 High Build Acrylic Waterborne Pavement Marking Paint.

- Third-Party Test Waiver for Concrete Aggregate

1.0 Description. Third party tests may be allowed for determining the durability factor for concrete pavement and concrete masonry aggregate.

2.0 Material. All aggregate for concrete shall be in accordance with Sec 1005.

2.1 MoDOT personnel shall be present at the time of sampling at the quarry. The aggregate sample shall be placed in an approved tamper-evident container (provided by the quarry) for shipment to the third-party testing facility.

2.2 AASHTO T 161 Method B Resistance of Concrete to Rapid Freezing and Thawing, shall be used to determine the aggregate durability factor. All concrete beams for testing shall be 3-inch wide by 4-inch deep by 16-inch long or 3.5-inch wide by 4.5-inch deep by 16-inch long. All beams for testing shall receive a 35-day wet cure fully immersed in saturated lime water prior to initiating the testing process.

2.3 Concrete test beams shall be made using a MoDOT approved concrete pavement mix design.

3.0 Testing Facility Requirements. All third-party test facilities shall meet the requirements outlined in this provision.

3.1 The testing facility shall be AASHTO accredited.

3.1.1 For tests ran after January 1, 2025, accreditation documentation shall be on file with the Construction and Materials Division prior to any tests being performed.

3.1.2 Construction and Materials Division may consider tests completed prior to January 1, 2025, to be acceptable if all sections of this provision are met, with the exception of 3.1.1. Accreditation documentation shall be provided with the test results for tests completed prior to January 1, 2025. No tests completed prior to September 1, 2024, will be accepted.

3.2 The testing facility shall provide their testing process, list of equipment, equipment calibration documentation, and testing certifications or qualifications of technicians performing the AASHTO T 161 Procedure B tests. The testing facility shall provide details on their freezing and thawing apparatus including the time and temperature profile of their freeze-thaw chamber. The profile shall include the temperature set points throughout the entirety of the freeze-thaw cycle. The profile shall show the cycle time at which the apparatus drains/fills with water and the cycle time at which the apparatus begins cooling the specimens.

3.3 Results, no more than five years old, from the third-party test facility shall compare within ± 2.0 percent of an independent test from another AASHTO accredited test facility or with MoDOT test records, in order to be approved for use (e.g. test facility results in a durability factor of 79, MoDOT's recent durability test factor is 81; this compared within +2 percent). The independent testing facility shall be in accordance with this provision. The comparison test can be from a different sample of the same ledge combination.

3.4 When there is a dispute between the third party durability test results and MoDOT durability test results, the MoDOT durability test result shall govern.

3.5 Test results shall be submitted to MoDOT's Construction and Materials division electronically for final approval. Test results shall include raw data for all measurements of relative modulus of elasticity and percent length change for each individual concrete specimen. Raw data shall include initial measurements made at zero cycles and every subsequent measurement of concrete specimens. Raw data shall include the cycle count and date each measurement was taken. Test results shall also include properties of the concrete mixture as required by AASHTO T 161. This shall include the gradation of the coarse aggregate sample. If AASHTO T 152 is used to measure fresh air content, then the aggregate correction factor for the mix determined in accordance with AASHTO T 152 shall also be included.

4.0 Method of Measurement. There is no method of measurement for this provision. The testing requirements and number of specimens shall be in accordance with AASHTO T 161 Procedure B.

5.0 Basis of Payment. No direct payment will be made to the contractor or quarry to recover the cost of aggregate samples, sample shipments, testing equipment, labor to prepare samples or test samples, or developing the durability report.

- **Delete paragraph 15.0 of the General Provision Disadvantaged Business Enterprise (DBE) Program Requirements and substitute the following:**

15.0 Bidder's List Quote Summary. MoDOT is a recipient of federal funds and is required by 49 CFR 26.11 to provide data about its DBE program. All bidders who seek to work on federally assisted contracts must submit data about all DBE and non-DBEs in accordance with Sec 102.7.9. MoDOT will not compare the submitted Bidder's List Quote Summary to any other documents or submittals, pre or post award. All information will be used by MoDOT in accordance with 49 CFR 26.11 for reporting to USDOT and to aid in overall DBE goal setting.

- **Add Sec 102.7.9 to include the following:**

102.7.9 Bidder's List Quote Summary. Each bidder shall submit with each bid a summary of all subcontractors, suppliers, manufacturers, and truckers considered on federally funded projects pursuant to 49 CFR 26.11. The bidder will provide the firm's name, the corresponding North American Industry Classification System (NAICS) code(s) the firm(s) were considered for, and whether or not they were used in the bid. The information submitted should be the most complete information available at the time of bid. The information shall be disclosed on the Bidder's List Quote Summary form provided in the bidding documents and submitted in accordance with Sec 102.10. Failure to disclose this information may result in a bid being declared irregular.

G. Utilities JSP-93-26F

1.0 For informational purposes only, the following is a list of names, addresses, and telephone numbers of the known utility companies in the area of the construction work for this improvement:

<u>Utility Name</u>	<u>Known Required Adjustment</u>	<u>Type</u>
AT&T Distribution Ken Lovette 600 W Pine Poplar Bluff, MO 63901 Phone: 573-686-1152 Mobile: 573-300-0490 Email: kl6298@att.com	None Section 2.1	Communications
Pemiscot County PWSD 1 Angie/Duey 309 E Broadway St Hayti, MO 63851 Phone: 573-359-1713 Email: conpwsd@sbglobal.net	None Section 2.2	Water
Pemiscot Dunklin Electric Co. Andy/JT 1240 Riggs St Kennett, MO 63857 Phone: 573-757-6641 Email: andy@pdec.coop	None Section 2.3	Fiber & Electric
City of Wardell Brett James 108 E Broad St Wardell, MO 63879 Phone: 573-628-3500 Email: jack@pdfiber.com	None Section 2.4	Utilities

1.1 The existence and approximate location of utility facilities known to exist, as shown on the plans, are based upon the best information available to the Owner at this time. This information is provided by the Owner "as-is" and the Owner expressly disclaims any representation or warranty as to the completeness, accuracy, or suitability of the information for any use. Reliance upon this information is done at the risk and peril of the user, and the Owner shall not be liable for any damages that may arise from any error in the information. It is, therefore, the responsibility of the contractor to verify the above listing information indicating existence, location and status of any facility. Such verification includes direct contact with the listed utilities.

2.0 Project Specific Provisions:

2.1 AT&T Distribution – has fiber located along the southern portion of the project limits. No adjustments are anticipated. Contact Ken Lovette four (4) weeks prior to the start of construction.

2.2 Pemiscot County PWSD 1 – no water line present in this location. No adjustments are anticipated. Contact Angie or Duey with Pemiscot County PWSD 1 with any questions.

2.3 Pemiscot Dunklin Electric COOP – No utilities present in this location. No adjustments are anticipated. The contractor shall contact Andy, with Pemiscot Dunklin Electric COOP, regarding any questions.

2.4 City of Wardell- no utilities are present in the project area. No adjustments are anticipated. The contractor shall contact Brett James regarding any questions.

H. Restrictions for Migratory Birds NJSP-16-06A

1.0 Description. Swallows or other bird species protected by the Migratory Bird Treaty Act may be nesting under the bridge or bridges that will be repaired under this contract.

2.0 Restrictions. To comply with the Migratory Bird Treaty Act, nests of protected species cannot be disturbed when active (eggs or young are present). Generally, nests are active between April 1 and July 31, but active nests can be present outside of these dates.

3.0 Avoidance Measures. The contractor shall not disturb active nests or destroy adults, eggs or young birds. In an effort to comply with the Migratory Bird Treaty Act, the contractor operations will be limited to the options established in the following sections.

3.1 Inactive or Partially Constructed Nests. If nests are present and MoDOT determines that the nests are inactive or partially constructed, the contractor may remove the nests provided that the colony's inactive or partially constructed nests are completely removed by March 15 and the contractor maintains a nest free condition until the bridge work is complete. Dry removal methods shall be used when practicable. If dry removal is not practicable, hydro cleaning may be used if approved by the Engineer and only if water is free of blasting grit, chemicals, or detergents, and applied using pressure less than 5,000 PSI. Clean water such as that from municipal water treatment plants or wells shall be used. Use of source water from Waters of the State (i.e., streams or lakes), is allowable, if the appropriate methods to prevent the possible spread of invasive aquatic species are implemented.

3.2 Water and Equipment Used for Hydro cleaning. Aquatic invasives such as zebra mussels and some algae species have infested several bodies of water in the United States and can be transported by vessels (barges, boats, tugs, tankers, etc.) and equipment (tanks, tubing, pumps, etc.) that have been used in areas that contain these invasive species. If equipment is not properly inspected and treated to prevent the spread of invasives, these species can be introduced into areas not currently known to have a population. These invasive species are detrimental to existing ecosystems and can outcompete native species. To assist in preventing the introduction and spread of aquatic invasive species through MoDOT projects in Missouri streams and lakes, the following precautions shall be followed.

3.2.1 Use of Water from Streams, Lakes or Ponds. Contractors shall not use water for nest removal from streams, lakes or ponds, unless they have implemented appropriate methods to prevent the possible spread of invasive aquatic species. Water sources from municipal water treatment plants or wells may be used without following these measures provided the equipment to be used has not previously contained waters from streams, lakes or ponds. If the equipment has previously contained waters from other streams or lakes, the following measures must be implemented prior to use.

3.2.1.1 Equipment Washing. Prior to the use or re-use of equipment following any use with water from streams, lakes or ponds, all equipment shall be washed and rinsed thoroughly with hard spray (power wash) and hot (minimum 120° F) water, for at least one minute.

3.2.1.2 Equipment Treating or Drying. Equipment shall be treated or dried in one of the following manners.

3.2.1.2.1 Equipment interior and/or other surfaces shall be treated with a 10% bleach solution to kill any aquatic nuisance species. This solution must also be run through all intake lines and hoses, to sterilize interior components. When chlorine treatment is used, all chlorine runoff from equipment washing must be collected and properly treated and/or disposed of in accordance with Sec 806.

3.2.1.2.2 Equipment interior and/or other surfaces shall be treated with 140° F water for a minimum of 10 seconds contact on all surfaces. 140 ° F water must also be run through all intake lines and hoses, to purge any standing water.

3.2.1.2.3 Equipment shall be flushed of all non-municipal water, and dried thoroughly, in the sun before using in or transporting between streams and lakes. Dry times will depend on the season the equipment is being used. Equipment must dry a minimum of 7 days for June-September, 18 days for March-May; 18 days for October-November, and 30 days for December-February. The drying method should be reserved as a last resort option.

3.2.2 Prior to use of equipment, contractors shall provide the MoDOT inspector written documentation of the equipment's geographic origin (including the water body it was last used in), as well as defining the specified treatment method used to adequately ensure protection against invasive species. The written documentation will include a statement indicating the contractor is aware of these provisions and will also treat the equipment appropriately after completion of the project.

3.3 Active Nests. The contractor may work on the bridge if active nests are present, as long as the work does not impact or disturb the birds and/or nests. At a minimum, work shall not be performed within 10 feet of an active nest; however, the contractor is responsible for ensuring their activities do not impact the nests, eggs, or young.

4.0 Additional Responsibilities. If active bird nests remain after all reasonable avoidance measures have been taken, or if bird nests are observed during project construction, the contractor shall notify the Resident Engineer and contact the MoDOT Environmental Section (573-526-4778) to determine if there are other allowable options.

I. Liquidated Damages for Winter Months JSP-04-17A

Delete Sec 108.8.1.3 (a)

Liquidated damages for failure to complete the work on time shall not be waived from December 15 to March 15, both dates inclusive.

J. Contractor Quality Control NJSP-15-42

1.0 The contractor shall perform Quality Control (QC) testing in accordance with the specifications and as specified herein. The contractor shall submit a Quality Control Plan (QC Plan) to the engineer for approval that includes all items listed in Section 2.0, prior to beginning work.

2.0 Quality Control Plan.

- (a) The name and contact information of the person in responsible charge of the QC testing.
- (b) A list of the QC technicians who will perform testing on the project, including the fields in which they are certified to perform testing.
- (c) A proposed independent third party testing firm for dispute resolution, including all contact information.
- (d) A list of Hold Points, when specified by the engineer.
- (e) The MoDOT Standard Inspection and Testing Plan (ITP). This shall be the version that is posted at the time of bid on the MoDOT website (www.modot.org/quality).

3.0 Quality Control Testing and Reporting. Testing shall be performed per the test method and frequency specified in the ITP. All personnel who perform sampling or testing shall be certified in the MoDOT Technician Certification Program for each test that they perform.

3.1 Reporting of Test Results. All QC test reports shall be submitted as soon as practical, but no later than the day following the test. Test data shall be immediately provided to the engineer upon request at any time, including prior to the submission of the test report. No payment will be made for the work performed until acceptable QC test results have been received by the engineer and confirmed by QA test results.

3.1.1 Test results shall be reported on electronic forms provided by MoDOT. Forms and Contractor Reporting Excel2Oracle Reports (CRE2O) can be found on the MoDOT website. All required forms, reports and material certifications shall be uploaded to a Microsoft SharePoint® site provided by MoDOT, and organized in the file structure established by MoDOT.

3.2 Non-Conformance Reporting. A Non-Conformance Report (NCR) shall be submitted by the contractor when the contractor proposes to incorporate material into the work that does not meet the testing requirements or for any work that does not comply with the contract terms or specifications.

3.2.1 Non-Conformance Reporting shall be submitted electronically on the Non-Conformance Report form provided on the MoDOT Website. The NCR shall be uploaded to the MoDOT SharePoint® site and an email notification sent to the engineer.

3.2.2 The contractor shall propose a resolution to the non-conforming material or work. Acceptance of a resolution by the engineer is required before closure of the non-conformance report.

4.0 Work Planning and Scheduling.

4.1 Two-week Schedule. Each week, the contractor shall submit to the engineer a schedule that outlines the planned project activities for the following two-week period. The two-week

schedule shall detail all work and traffic control events planned for that period and any Hold Points specified by the engineer.

4.2 Weekly Meeting. When work is active, the contractor shall hold a weekly project meeting with the engineer to review the planned activities for the following week and to resolve any outstanding issues. Attendees shall include the engineer, the contractor superintendent or project manager and any foreman leading major activities. This meeting may be waived when, in the opinion of the engineer, a meeting is not necessary. Attendees may join the meeting in person, by phone or video conference.

4.3 Pre-Activity Meeting. A pre-activity meeting is required in advance of the start of each new activity, except when waived by the engineer. The purpose of this meeting is to review construction details of the new activity. At a minimum, the discussion topics shall include: safety precautions, QC testing, traffic impacts, and any required Hold Points. Attendees shall include the engineer, the contractor superintendent and the foreman who will be leading the new activity. Pre-activity meetings may be held in conjunction with the weekly project meeting.

4.4 Hold Points. Hold Points are events that require approval by the engineer prior to continuation of work. Hold Points occur at definable stages of work when, in the opinion of the engineer, a review of the preceding work is necessary before continuation to the next stage.

4.4.1 A list of typical Hold Point events is available on the MoDOT website. Use of the Hold Point process will only be required for the project-specific list of Hold Points, if any, that the engineer submits to the contractor in advance of the work. The engineer may make changes to the Hold Point list at any time.

4.4.2 Prior to all Hold Point inspections, the contractor shall verify the work has been completed in accordance with the contract and specifications. If the engineer identifies any corrective actions needed during a Hold Point inspection, the corrections shall be completed prior to continuing work. The engineer may require a new Hold Point to be scheduled if the corrections require a follow-up inspection. Re-scheduling of Hold Points require a minimum 24-hour advance notification from the contractor unless otherwise allowed by the engineer.

5.0 Quality Assurance Testing and Inspection. MoDOT will perform quality assurance testing and inspection of the work, except as specified herein. The contractor shall utilize the inspection checklists provided in the ITP as a guide to minimize findings by MoDOT inspection staff. Submittal of completed checklists is not required, except as specified in 5.1.

5.1 Inspection and testing required in the production of concrete for the project shall be the responsibility of the contractor. Submittal of the 501 Concrete Plant Checklist is required.

6.0 Basis of Payment. No direct payment will be made for compliance with this provision.

K. Modified Linear Grading Class 2

1.0 Description. Modified Linear Grading, Class 2, shall consist of contractor-furnished fill, embankment construction, excavating and grading existing shoulders to facilitate placement of pavement and base, grading of ditches and slopes, and final shaping necessary to conform to the

lines and grades in the plans, and shall conform to all applicable portions of Sec 207 and specifically as follows.

2.0 Construction Requirements.

2.1 It may be necessary to go outside the limits of the right of way to obtain additional material. All contractor furnished material shall be approved by the Engineer prior to being incorporated into the project.

2.2 The Engineer shall have sole discretion in determining whether excess material may be incorporated within right-of-way or must be disposed of outside of right-of-way.

2.3 All areas to be graded shall be cleared and grubbed in accordance with Sec 201 or as directed by the Engineer. No measurement or payment will be made for clearing and grubbing.

2.4 Roadside ditches shall be graded to match the existing flowline unless shown otherwise in the plans. Grading for pipe extensions shall match the projected flowline of the existing pipe.

2.5 Any damage to existing drainage structures or existing pavement, resulting from the Contractor's operations, shall be repaired at the Contractor's expense and to the satisfaction of the Engineer.

3.0 Method of Measurement. Measurement will be made to the nearest 1/10 station for the length of grading measured along the centerline of the traveled way.

4.0 Basis of Payment. All costs incurred by the Contractor to comply with this provision shall be considered completely covered by the contract unit price for Item 207-99.09, Modified Linear Grading, Class 2. No direct payment will be made for contractor furnished material or disposal of excess material.

L. Damage to Existing Roadways and Entrances

1.0 Description. This work shall consist of repairing any damage to existing pavement, shoulders, side roads, and entrances caused by Contractor operations. This shall include, but is not limited to, damage caused by the traffic during Contractor operations within the project limits including the work zone signing.

2.0 Construction Requirements. Any cracking, gouging, or other damage to the existing pavement, shoulders, side roads, or entrances from general construction shall be repaired within twenty-four (24) hours of the time of damage at the Contractor's expense. Repair of the damaged pavement, shoulders, side roads, or entrances shall be as determined by the Engineer.

3.0 Method of Measurement. No measurement of damaged pavement, shoulder, side roads, or entrances, as described above, shall be made.

4.0 Basis of Payment. No payment will be made for repairs to existing pavement, shoulders, side roads or entrances damaged by Contractor operations.

M. Temporary Stream Crossings and Workpads

1.0 Description. This work shall include construction of a temporary stream crossing or workpad to facilitate the placement of the Contractor's equipment in the stream, in accordance with Division 100 of the General Provisions, Section 806.1 of the Standard Specifications, and as follows.

2.0 Construction Requirements. The Contractor shall be solely responsible for the design, installation, maintenance, and removal of the temporary stream crossing or workpad, as well as any structures installed to maintain proper flow while the temporary crossing or workpad is in place.

2.1 Temporary crossings and workpads shall be constructed of clean rock fill in accordance with Sec 303.2, except Sec 303.2.3 shall not apply.

2.2 The Contractor shall design the temporary crossing or workpad, including the size and number of pipes, to maintain normal flows, prevent upstream flooding, and allow free movement of aquatic life in the stream.

2.3 Storm water from the approaches to temporary crossings or workpads must be diverted to appropriate erosion control devices to allow sediment-laden runoff to be treated prior to entering the stream.

2.4 Pipes shall be anchored to prevent being swept from the project during high flows.

2.5 Temporary stream crossings and workpads shall not conflict with existing utilities. Any utilities that conflict with the construction of a temporary crossing/workpad or operation of equipment on a temporary crossing/workpad shall be relocated at the Contractor's expense.

3.0 Basis of Payment. No direct payment will be made for any equipment, labor, material, or time involved with the design, installation, maintenance, or removal of temporary stream crossings and workpads. The contractor shall be responsible for all costs, including damage and penalties.

N. DBE Prompt Payment Reporting JSP-24-05B

1.0 Description.

1.1 This provision will only apply to contracts that have a Disadvantaged Business Enterprise (DBE) goal greater than 0% and have at least one DBE subcontractor.

1.2 MoDOT monitors the payments made by prime contractors and subcontractors to DBEs for compliance with DBE payment monitoring rules as outlined in 49 CFR 26.37. To facilitate this monitoring, MoDOT requires prime contractors to report their remitted payments to DBEs and subcontractors to report their remitted payments to lower-tier DBEs.

1.3 Tracking of DBE payments are made through the Signet™ application (Signet). Signet is a third-party service, supported by the vendor, for usage by the prime contractor and all subcontractors. Signet is only a reporting tool; it does not process financial transactions. MoDOT does not provide direct technical support for Signet. Information about Signet may be found at <https://signet-help.zendesk.com/hc/en-us>.

1.4 Upon completion of the first pay estimate on the contract, Signet will automatically send an email to the prime contractor prompting registration. The prime will be required to pay a one-time, fixed fee of \$1,000 for this contract directly to the Signet vendor. Use of Signet to track DBE payments will be available for the life of the contract, regardless of the contract value, contract duration, number of subcontractors, or payments reported. No additional fee will be charged to subcontractors that are required to report payments or DBEs that are required to verify payments through Signet. The contractor may also, at no additional cost, report payments through Signet to subcontractors that are not DBEs.

1.5 After each estimate, when contractor reporting of payments is complete, the subcontractor will receive an email notifying them of the payment and requesting verification of the reported payment. A subcontractor that has not completed registration with Signet will be prompted to do so at this time.

1.6 Users will be set up automatically based on information in MoDOT's vendor list. Additional users under each contractor may be added once registration has been completed within Signet. The current vendor list can be found at <https://www.modot.org/bid-opening-info>.

1.7 For purposes of this requirement, payer is defined as the prime contractor or subcontractor that reports a payment in Signet to a vendor that is either a subcontractor, trucker, manufacturer, regular dealer, or broker. Payee is defined as the vendor that receives notification of payment through Signet from the prime contractor or a higher-tier subcontractor. Payment is defined as issuing an Electronic Funds Transfer (EFT) or mailing a check to a payee.

2.0 Requirements. Payers must report remitted payment to DBEs within Signet, for work performed by the DBE subcontractor, DBE trucking, materials supplied from a DBE manufacturer, dealer, or broker, as well as a return of retainage (and/or other amounts withheld), within 15 calendar days.

2.1 Prime contractors must report remitted payments to DBEs within 15 calendar days of each payment it receives from MoDOT. Prime contractors must also report payments to non-DBE subcontractors if that subcontractor is making payment to a lower tier DBE subcontractor, trucker, manufacturer, regular dealer, or broker.

2.2 The payer must report the following information within Signet:

- a. The name of the payee.
- b. The dollar amount of the payment to the payee.
- c. The date the payment was made.
- d. Any retainage or other amount withheld (if any) and the reason for the withholding (if other than retainage).
- e. The DBE function performed for this payment (e.g., contracting, trucking, or supplying as a manufacturer, dealer, or broker).
- f. Other information required by Signet.

The payer must report its return of retainage (and/or other amounts withheld) in separate, standalone payment entries (i.e., without being comingled with a payment for work performed or materials supplied).

2.3 In the event that no work has been completed by a DBE during the estimate period, such that no payment is due to a DBE subcontractor, trucker, manufacturer, regular dealer, or broker, then the prime contractor will mark payment complete within Signet, and no other payments are required to be reported.

2.4 Each subcontractor making a payment to a lower-tier DBE must report remitted payments within Signet, as detailed in Section 2.2, within 15 days of receipt of each payment from the prime contractor.

2.5 DBE payees must verify in Signet each payment reported by a payer within 15 calendar days of the payment being reported by the payer. This verification includes whether the payment was received, and if so, whether it was as expected.

3.0 Basis of Payment. A fixed cost of \$1,000 will be paid on this contract for the required software to report payments to DBEs through Signet. Regardless of the number of projects in a contract, a single payment will be made under item 108-10.00, SIGNET DBE REPORTING, per lump sum. The engineer reserves the right to underrun this item for any reason. Any additional costs for registration, software, usage, time, labor, or other costs will be considered incidental and no direct payment will be made.

O. Optional Pavements JSP 06-06H

1.0 Description. This work shall consist of a pavement composed of either Portland cement concrete or asphaltic concrete constructed on a prepared subgrade. This work shall be performed in accordance with the standard specifications and as shown on the plans or established by the engineer.

2.0 The quantities shown reflect the total square yards of pavement surface designated for each pavement type as computed and shown on the plans.

2.1 No additional payment will be made for asphaltic concrete mix quantities to construct the required 1:1 slope along the edge of the pavement, or for tack applied between lifts of asphalt.

2.2 No additional payment will be made for aggregate base quantities outside the limits of the final surface area as computed and shown on the plans. When A2 shoulders are specified, payment for aggregate base will be as shown on the plans.

2.3 The grading shown on the plans was designed for the thicker pavement option. For projects with grading in the contract, there will be no adjustment of the earthwork quantities due to adjusting the roadway subgrade for optional pavements.

2.4 The contractor shall comply with Sections 401 through 403 for the asphalt option and Sections 501 and 502 for the concrete option.

2.5 Pavement options composed of Portland cement concrete shall have contrast pavement marking for intermittent markings (skips), dotted lines, and solid intersection lane lines. The pavement markings shall be in accordance with Section 620. No additional payment will be made for the contrast pavement markings.

3.0 Method of Measurement. The quantities of concrete pavement will be measured in accordance with Section 502.14. The quantities of asphaltic concrete pavement will be measured in accordance with Section 403.22.

4.0 Basis of Payment. The accepted quantity of the chosen option will be paid for at the contract unit bid price for Item 403-99.05, Optional Pavement, per square yard.

4.1 For projects with previously graded roadbeds, any additional quantities required to bring the roadway subgrade to the proper elevation will be considered completely covered by the pay item for Subgrading and Shouldering.

4.2 Price Adjustment for Fuel. If the contractor accepts the option for fuel adjustment in the bid proposal, a fuel adjustment will be applied in accordance with Sec 109.14 for the type of pavement constructed.

P. Flap Gate

1.0 Description. This work shall consist of furnishing and installing flap gates of standard design and fit the opening shown on the plans.

2.0 Materials. Flap gates shall be constructed as follows.

BILL OF MATERIAL		
P.C. #	DESCRIPTION	# REQUIRED
1	CONNECTING BAND - VAR LENGTH (A)	1
2	1/4" x 2" BAR x 2 1/2" LONG	2
3	1/4" PLATE COVER VAR DIA. (B) - UP TO 24" DIA. PIPE 3/8" PLATE COVER VAR DIA. (B) - ALL PIPES GREATER THAN 24" DIA.	1
4	1/4" x 2" BAR x VAR LENGTH (C)	2
5	1/4" x 2" BAR x 2" LONG W/BRASS BUSHINGS	2
6	7/16" Ø ROD x 8 1/2" LONG	1
7	FLAT BAND LUGS	2
8	1/2" Ø x 6" BAND BOLT & NUT	1
ATTACHMENT BOLTS (3/8" Ø x 1 1/2" HEX. HEAD)		4

2.1 As a standard finish all gates shall be painted with a shop coat of red oxide.

3.0 Construction Requirements. Flap gates shall react to any difference in water level, and shall be hinged to seat accurately. Flap gates shall be constructed according to Figure 1 – Dimension Details, Figure 2 – Connecting Band and Figure 3 – Cover Plate.

4.0 Method of Measurement. For the basis of this contract, all materials used in constructing the flap gate shall be considered as a single unit. Measurement will be made per each unit installed by the contractor and accepted by the engineer.

5.0 Basis of Payment. The accepted quantity for flap gates, complete in place including connection to the pipe, will be paid for at the contract unit bid price for Item 614-99.02, 18 IN. Flap

Gate, per each, and Item 614-99.02, 24 IN. Flap Gate, per each. No additional payment will be made for any labor, equipment or time necessary to fulfill the requirements of this special provision.

DIMENSION DETAILS			
PIPE DIA.	(A) CONNECTING BAND LENGTH	(B) PLATE COVER DIA.	(C) BAR LENGTH
15"	54"	18.5"	16"
18"	64"	21.5"	19"
21"	74"	24.5"	22"
24"	83"	27.5"	25"
30"	102"	33.5"	31"
36"	120"	39.5"	36"
42"	140"	45.5"	42"
48"	159"	51.5"	49"

Figure 1 – Dimension Details

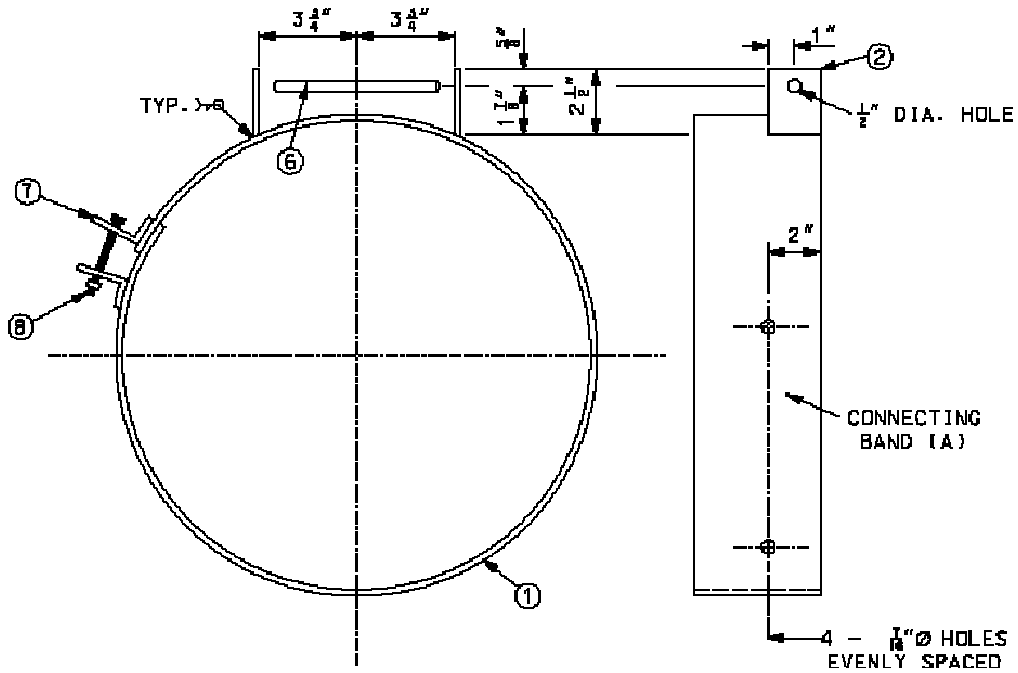

Figure 2 – Connecting Band

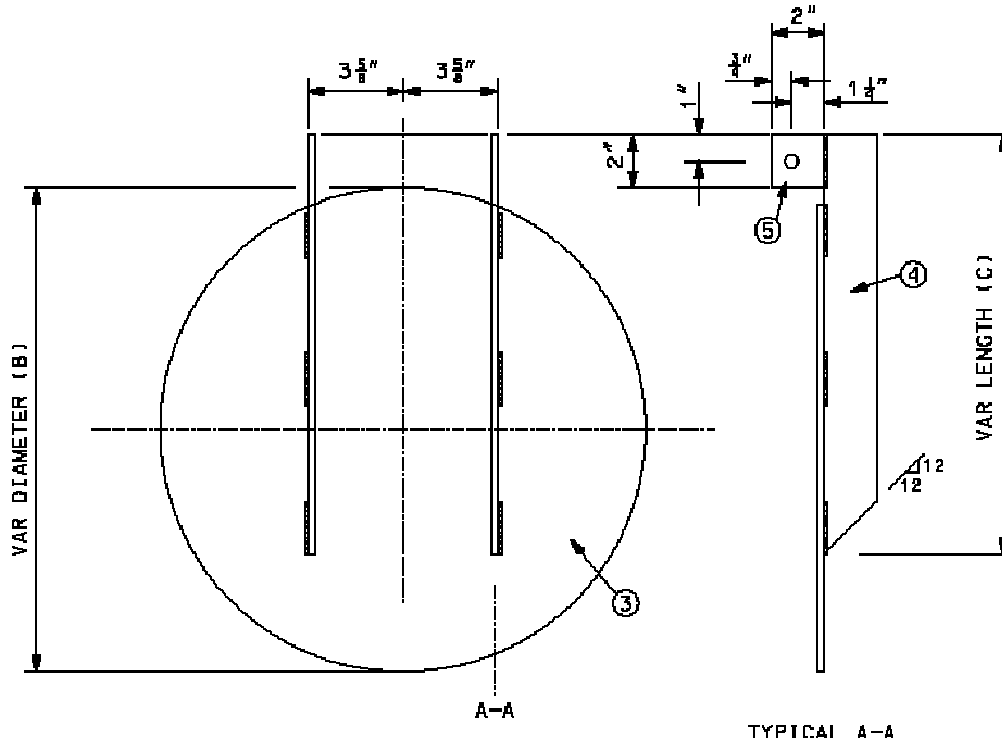

Figure 3 – Cover Plate