

SINGLE LANE CLOSURE

NOTES:
SEE TCP SHEET 1 FOR SIGN SPACING AND TAPER LENGTHS.

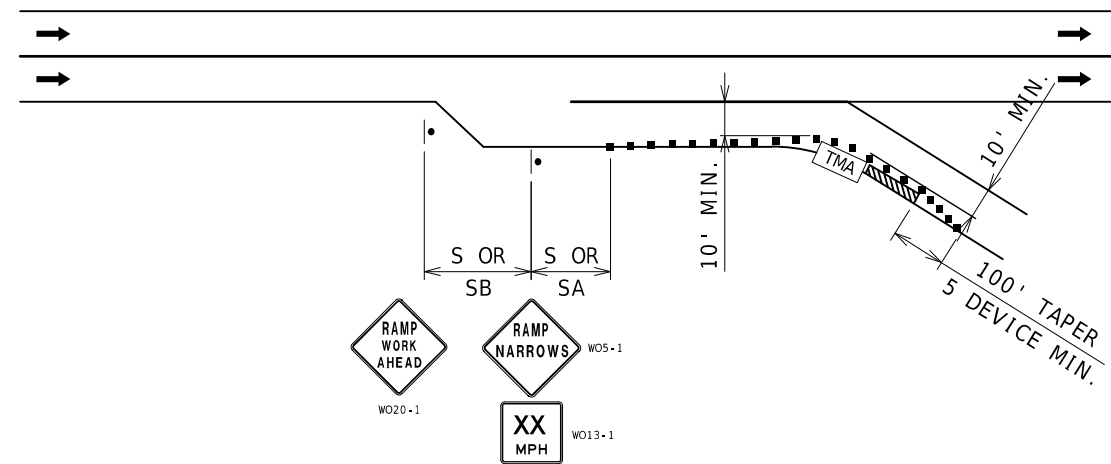

PARTIAL RAMP CLOSURE

NOTES:
SEE TCP SHEET 1 FOR SIGN SPACING AND TAPER LENGTHS.

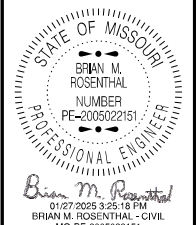

DATE PREPARED
1/21/2025
ROUTE VAR. MO
DISTRICT NW SHEET NO. 6
COUNTY VARIOUS
JOB NO. JNW0065
CONTRACT ID.
PROJECT NO.
BRIDGE NO.

DATE	DESCRIPTION

MISSOURI HIGHWAYS AND TRANSPORTATION COMMISSION

 105 WEST CAPITOL
 JEFFERSON CITY, MO 65102
 1-888-ASK-MODOT (1-888-273-6636)

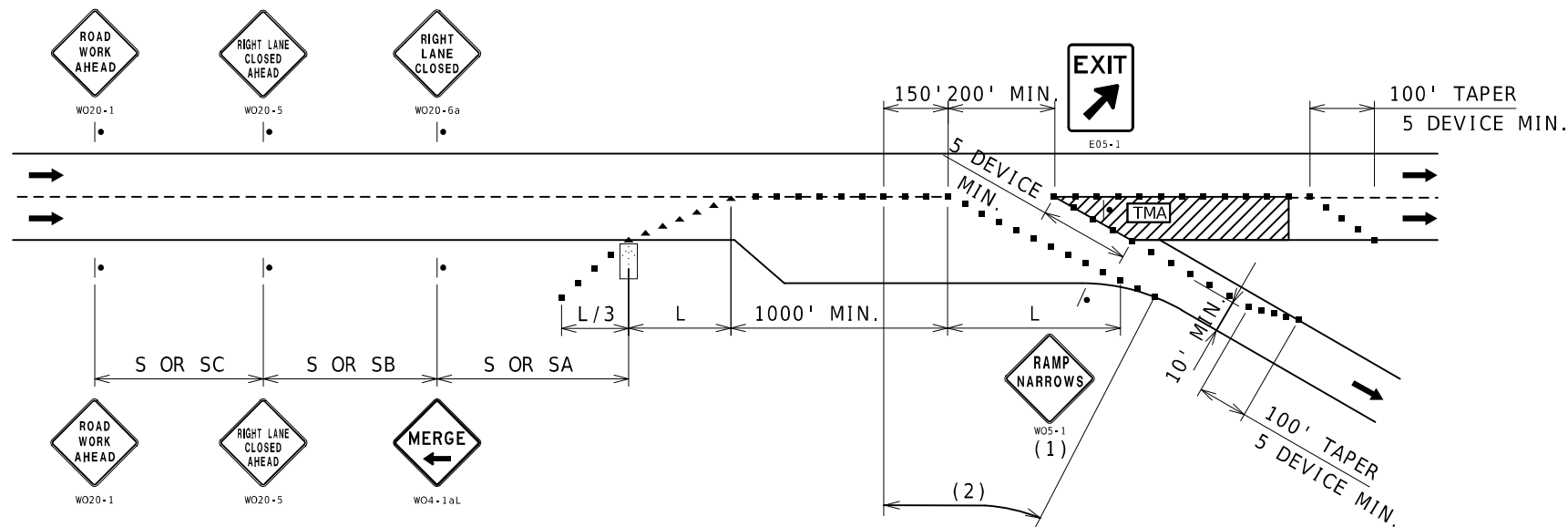

NOTES:

SEE TCP SHEET 1 FOR SIGN SPACING AND TAPER LENGTHS.

(1) SIGN ONLY REQUIRED WHEN RAMP WIDTH IS REDUCED.

(2) CHANNELIZER SPACING AT 50'.

EXIT RAMP AREA MAINLINE WORK

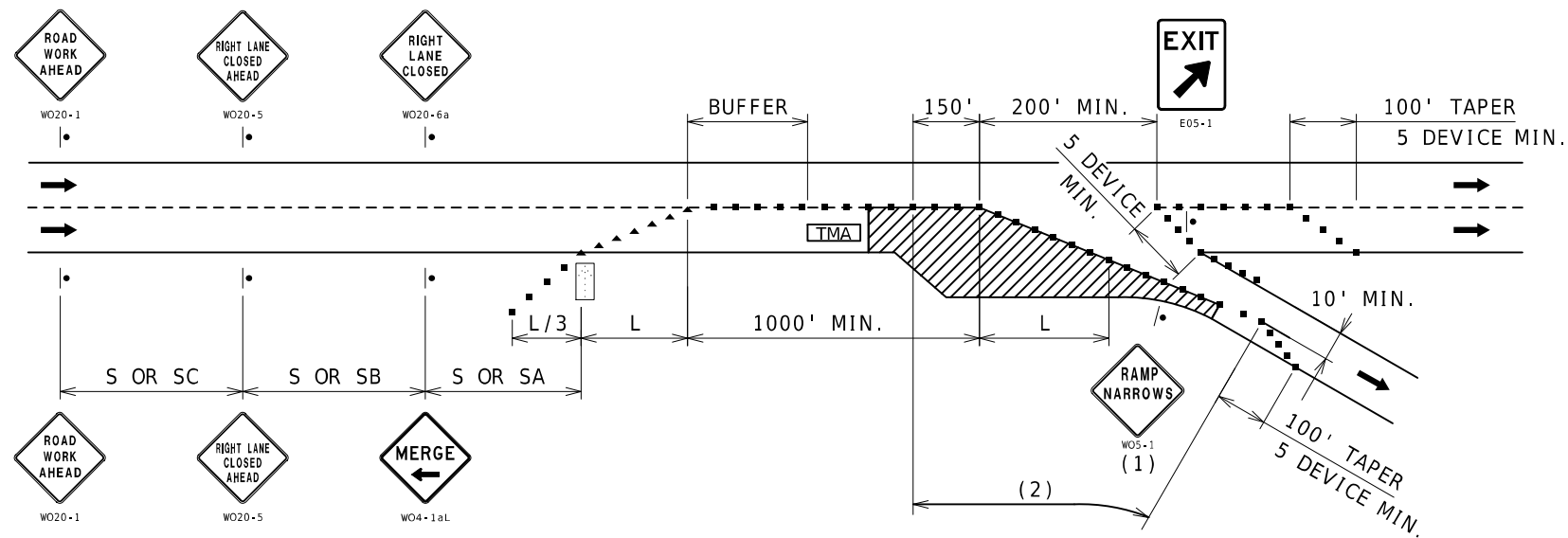

NOTES:

SEE TCP SHEET 1 FOR SIGN SPACING AND TAPER LENGTHS.

(1) SIGN ONLY REQUIRED WHEN RAMP WIDTH IS REDUCED.

(2) CHANNELIZER SPACING AT 50'.

EXIT RAMP AREA DECELERATION LANE WORK

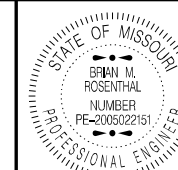

Brian M. Rosenthal
01/27/2025 3:26:03 PM
BRIAN M. ROSENTHAL - CIVIL
MO-PE-2005022151

DATE PREPARED
1/21/2025

ROUTE STATE
VAR. MO

DISTRICT SHEET NO.
NW 8

COUNTY
VARIOUS

JOB NO.
JNW0065

CONTRACT ID.

PROJECT NO.

BRIDGE NO.

DESCRIPTION

DATE

DESCRIPTION

DATE

DESCRIPTION

DATE

DESCRIPTION

DATE

DESCRIPTION

DATE

DESCRIPTION

DATE

DESCRIPTION

DATE

DESCRIPTION

DATE

DESCRIPTION

DATE

DESCRIPTION

DATE

DESCRIPTION

DATE

DESCRIPTION

DATE

DESCRIPTION

DATE

DESCRIPTION

DATE

DESCRIPTION

DATE

DESCRIPTION

DATE

DESCRIPTION

DATE

DESCRIPTION

DATE

DESCRIPTION

DATE

DESCRIPTION

DATE

DESCRIPTION

DATE

DESCRIPTION

DATE

DESCRIPTION

DATE

DESCRIPTION

DATE

DESCRIPTION

DATE

DESCRIPTION

DATE

DESCRIPTION

MISSOURI HIGHWAYS AND TRANSPORTATION
COMMISSION
MoDOT
105 WEST CAPITOL
JEFFERSON CITY, MO 65102
1-888-ASK-MODOT (1-888-273-6636)

TRAFFIC CONTROL
SHEET 7 OF 9

