

SECTION ON TANGENT
RTE W
LM 11.847 TO LM 12.116

2' TO 8' SHOULDER OVERLAY WITH WEDGING DETAIL

MATCH EXISTING SHOULDER WIDTH UPTO 8'

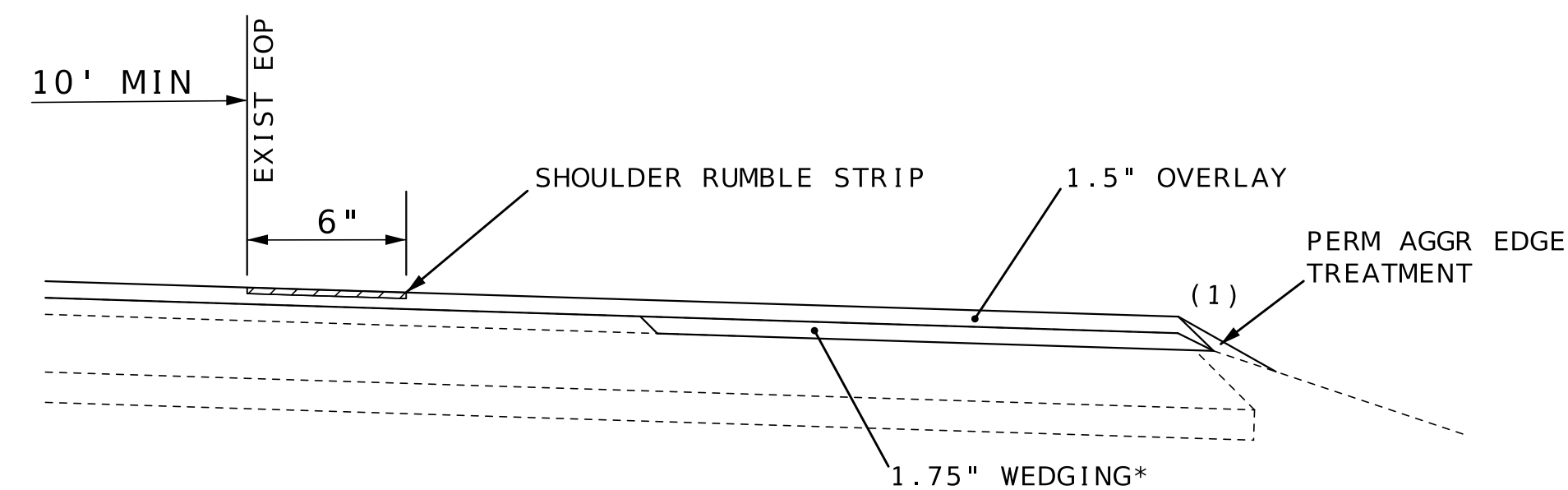

LM 11.847 TO LM 12.116 LT & RT

* PLACE 1.75" BP-2 PG70-22 FOR SHOULDERS PRIOR TO PLACING MAINLINE PAVEMENT.

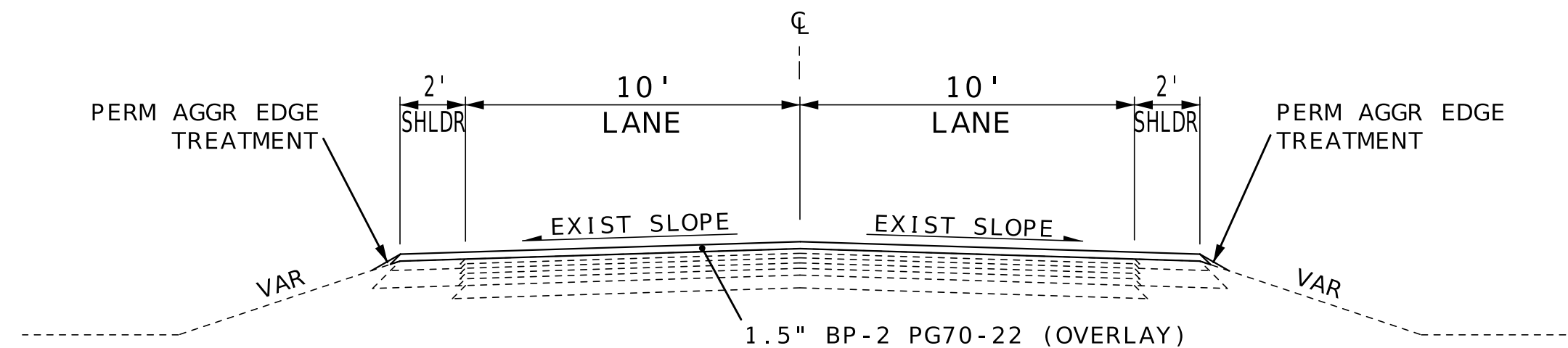

SECTION ON TANGENT
RTE W
LM 12.116 TO LM 13.053
LM 13.609 TO LM 15.508

≤ 2' SHOULDER OVERLAY DETAIL

MATCH EXISTING SHOULDER WIDTH UPTO 2'

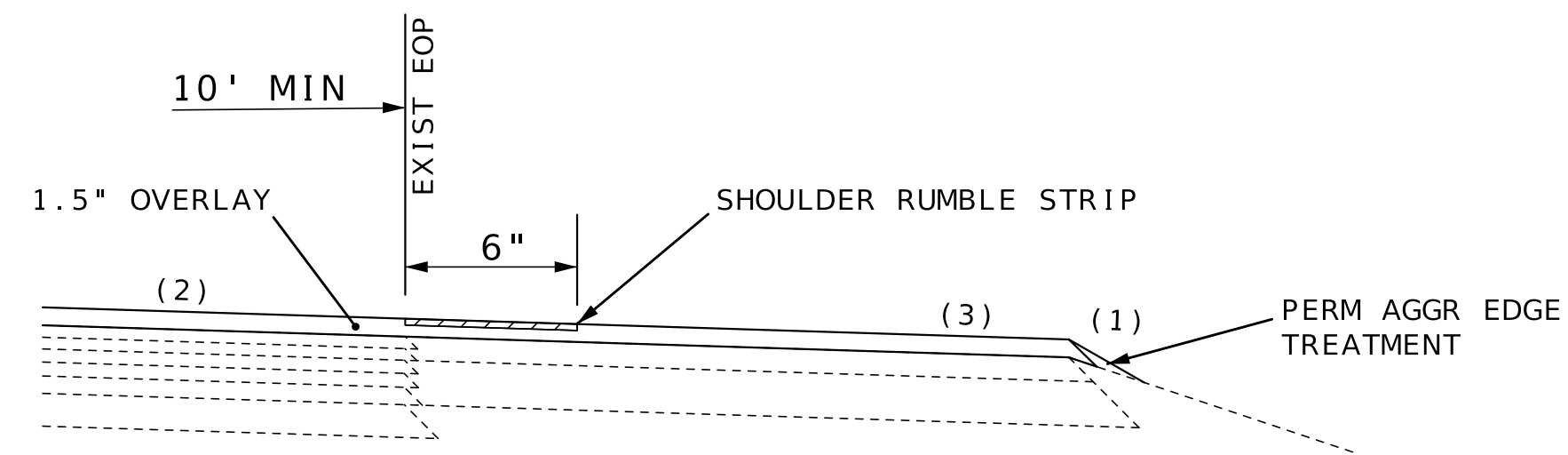

LM 12.116 TO LM 15.734 LT & RT

- (1) SAFETY EDGE (SEE STD 401.00C).
- (2) EDGE LINE RUMBLE STRIPS SHALL BE PLACED AT LOCATIONS WHERE THERE IS A MINIMUM OF 10' BETWEEN THE CENTERLINE JOINT AND THE INSIDE EDGE OF THE RUMBLE STRIP.
- (3) SHOULDERS ≤ 4' SHALL BE PLACED MONOLITHIC WITH MAINLINE PAVEMENT.

NOTES:

ANY EXISTING PAVEMENT SHOWN IS FOR INFORMATIONAL PURPOSES ONLY. LAYERS MAY VARY FROM TYPICALS.

INSTALL SAFETY EDGE ON ALL SHOULDER PAVEMENT WIDTHS ≤ 4'.

DRAWING NOT TO SCALE. FOLLOW DIMENSIONS.

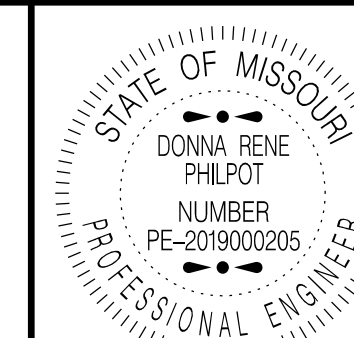

Donna Rene Philpot
102182620 10/4/21 AM
DONNA RENE PHILPOT - CIVIL
MO-PE-2019000205

DATE PREPARED
2/11/2026

ROUTE STATE
W MO

DISTRICT SHEET NO.
SE 2

COUNTY
BUTLER

JOB NO.
J9S3781

CONTRACT ID.

PROJECT NO.

BRIDGE NO.

DESCRIPTION

DATE

DATE

DATE

DATE

DATE

DATE

DATE

DATE

DATE

DATE

DATE

DATE

DATE

DATE

DATE

DATE

DATE

DATE

DATE

DATE

DATE

DATE

DATE

DATE

DATE

DATE

DATE

DATE

DATE

DATE

DATE

DATE

DATE

DATE

DATE

DATE

DATE

DATE

DATE

DATE

DATE

DATE

DATE

DATE

DATE

DATE

DATE

DATE

DATE

MISSOURI HIGHWAYS AND TRANSPORTATION COMMISSION
105 WEST CAPITOL
JEFFERSON CITY, MO 65102
1-888-ASK-MODOT (1-888-275-6636)

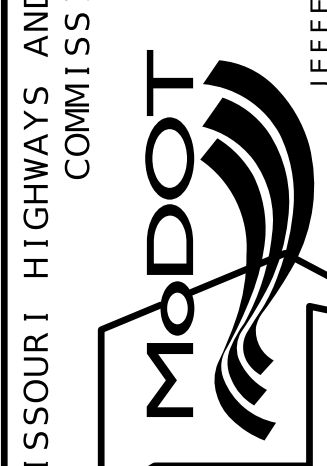

TYPICAL SECTION
SHEET 1 OF 2

PAVEMENT REPAIRS									
LM	LOC	LENGTH FT	WIDTH FT	FULL DEPTH SY	SUBGRADE COMPACTION FOR PAVEMENT REPAIR SY	4" TYPE 1 OR 5 BASE BASE FOR PAVEMENT REPAIR SY	FULL DEPTH PAVEMENT REPAIR SAW CUT FT	DOWELL BARS DRILLED EA	REMARKS
15.625	LT & RT	6	24	16.00	1.6	1.6	60.0	20.0	RTE W RT & LT LANE
15.758	LT & RT	6	24	16.00	1.6	1.6	60.0	20.0	RTE W RT & LT LANE
15.824	LT & RT	6	24	16.00	1.6	1.6	60.0	20.0	RTE W RT & LT LANE
15.882	LT & RT	6	24	16.00	1.6	1.6	60.0	20.0	RTE W RT & LT LANE
15.970	LT & RT	10	24	26.67	2.7	2.7	68.7	20.0	RTE W LT TURN LANE & LT LANE
			TOTAL	90.7	10	10	309	100	

SUBGRADE COMPACTION FOR PAVEMENT REPAIR AND 4" TYPE 1 OR 5 BASE FOR PAVEMENT REPAIR QUANTITIES ARE CALCULATED AT 10% OF THE TOTAL AREA OF FULL DEPTH PAVEMENT REPAIR.
ALL LOCATIONS AND PAVEMENT REPAIR SIZES ARE APPROXIMATE AND MAY BE ADJUSTED AS DIRECTED BY THE ENGINEER.
LOG MILES ARE APPROXIMATE. EXACT LOCATIONS TO BE DETERMINED BY THE ENGINEER.

PAVEMENT MARKING										
LM	LM	CLASS 1 PAVEMENT MARKINGS HIGH BUILD WATERBORNE PAINT TYPE P BEADS			PREFORMED THERMOPLASTIC					REMARKS
		4" INT YELLOW LF	4" SOLID YELLOW LF	4" SOLID WHITE LF	24" YELLOW HASH BARS LF	24" WHITE STOP LINE LF	R/R CROSSING EA	LT/RT ARROWS EA	COMBINATION STR/LT/RT EA	
11.847	15.974	1128.5	37441.5	41878.9						
11.852						12.0				STOP LINE ON RTE W TRANSITION (NORTH)
12.946							1			R/R CROSSING RT LANE (EAST)
13.050						10.0				R/R CROSSING STOP LINE (EAST)
13.058						10.0				R/R CROSSING STOP LINE (WEST)
13.160							1			R/R CRSSING LT LANE (WEST)
15.933					71.0					MEDIAN ISLAND MARKINGS BEGIN
15.942								1		LEFT-THROUGH TURN LANE ARROW (RT LANE)
15.951								1		RIGHT TURN LANE ARROW (LT LANE)
15.974								1		LEFT-THROUGH TURN LANE ARROW (RT LANE)
15.974								1		LEFT TURN LANE ARROW (RT LANE)
	TOTAL	38570		41879	71	32	2	2	2	

LOG MILES ARE APPROXIMATE.

PERMANENT AGGREGATE EDGE TREATMENT							
LM	LM	LOC	LENGTH FT	WIDTH FT	DEPTH IN	PERM AGG EDGE TREATMENT 1.7 TONS/CY TONS	REMARKS
11.847	13.053	LT	6367.68	2	4	133.64	
13.609	15.508	LT	10026.72	2	4	210.44	
11.847	13.053	RT	6367.68	2	4	133.64	
13.609	15.508	RT	10026.720	2	4	210.44	
					TOTAL	688.2	

DIMENSIONS MAY BE ADJUSTED AS APPROVED BY THE ENGINEER.

MOBILIZATION
LUMP SUM ONE

GRAVEL A OR CRUSHED STONE B							
LM	LM	LOC	LENGTH FT	WIDTH FT	DEPTH IN	GRAVEL A OR CRUSHED STONE B 1.75 TON/CY TONS	REMARKS
11.857	15.974	LT & RT	1475	4	1.5	23.9	UNPAVED PRIVATE & COMMERCIAL ENTRANCES
11.857	15.974	LT & RT	285	4	1.5	4.6	UNPAVED CITY STREET ENTRANCES
					TOTAL	29	

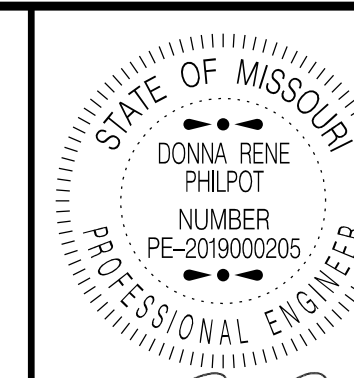

Donna Rene Philpot
1621 BRIDGE LANE 13 PM
DONNA RENE PHILPOT - CIVIL
MO-PE-2019000205

DATE PREPARED
2/18/2026

ROUTE STATE
W MO

DISTRICT SHEET NO.
SE 3

COUNTY
BUTLER

JOB NO.
J9S3781

CONTRACT ID.

PROJECT NO.

BRIDGE NO.

DESCRIPTION

DATE

DATE

DATE

DATE

DATE

DATE

DATE

DATE

DATE

DATE

DATE

DATE

DATE

DATE

DATE

DATE

DATE

DATE

DATE

DATE

DATE

DATE

DATE

DATE

DATE

DATE

DATE

DATE

DATE

DATE

DATE

DATE

DATE

DATE

DATE

MISSOURI HIGHWAYS AND TRANSPORTATION
COMMISSION
105 WEST CAPITOL
JEFFERSON CITY, MO 65102
1-888-ASK-MODOT (1-888-275-6636)

SUMMARY OF QUANTITIES
SHEET 2 OF 3

EFFECTIVE: 07-01-2025																				
SIGN	SIZE	AREA	QTY	TOTAL	QTY	TOTAL	SIGN	DESCRIPTION	SIGN	SIZE	AREA	QTY	TOTAL	QTY	TOTAL	SIGN	DESCRIPTION	ITEM	TOTAL	DESCRIPTION
IN.	SQ.FT.	EACH	SQ.FT.	EACH	SQ.FT.	NO.			IN.	SQ.FT.	EACH	SQ.FT.	EACH	SQ.FT.	NO.		NUMBER	QTY		
WARNING SIGNS									GUIDE SIGNS											
WO1-1L	48X48	16.00						TURN (SYMBOL LEFT)	E05-1	36X48	12.00							6122008		IMPACT ATTENUATOR 40 MPH (SAND BARRELS)
WO1-1R	48X48	16.00						TURN (SYMBOL RIGHT)	E05-2	48X36	12.00							6122009		IMPACT ATTENUATOR 45 MPH (SAND BARRELS)
WO1-2L	48X48	16.00						CURVE (SYMBOL LEFT)	E05-2a	48X36	12.00							6122010		IMPACT ATTENUATOR 50 MPH (SAND BARRELS)
WO1-2R	48X48	16.00						CURVE (SYMBOL RIGHT)	GO20-1	60X24	10.00	2	20.00					6122012		IMPACT ATTENUATOR 55 MPH (SAND BARRELS)
WO1-3L	48X48	16.00						REVERSE TURN (SYMBOL LEFT)	GO20-2	48X24	8.00	2	16.00					6122014		IMPACT ATTENUATOR 60 MPH (SAND BARRELS)
WO1-3R	48X48	16.00						REVERSE TURN (SYMBOL RIGHT)	GO20-4	36X18	4.50	1	4.50					6122017		IMPACT ATTENUATOR 65 MPH (SAND BARRELS)
WO1-4L	48X48	16.00						REVERSE CURVE (SYMBOL LEFT)	GO20-4a	42X30	8.75	1	8.75					6122019		IMPACT ATTENUATOR 70 MPH (SAND BARRELS)
WO1-4R	48X48	16.00						REVERSE CURVE (SYMBOL RIGHT)	GO20-4a	18X12	1.50	7	10.50					6122020		REPLACEMENT SAND BARREL
WO1-4bL	48X48	16.00						DOUBLE ARROW REVERSE CURVE (SYMBOL LEFT)	GO20-5aP	36X24	6.00							6122030		IMPACT ATTENUATOR (RELOCATION)
WO1-4bR	48X48	16.00						DOUBLE ARROW REVERSE CURVE (SYMBOL RIGHT)	MO4-8a	24X18	3.00							6122040		WORK ZONE CRASH CUSHION (NARROW)
WO1-4cL	48X48	16.00						TRIPLE ARROW REVERSE CURVE (SYMBOL LEFT)	MO4-9L	48X36	12.00							6122041		WORK ZONE CRASH CUSHION (RELOCATION)
WO1-4cR	48X48	16.00						TRIPLE ARROW REVERSE CURVE (SYMBOL RIGHT)	MO4-9R	48X36	12.00							6123001		TRUCK MOUNTED ATTENUATOR (TMA)
WO1-6	60X30	12.50						HORIZONTAL ARROW (SYMBOL)	MO4-9P	48X12	4.00							6161012		BUOYS (BOATS KEEP OUT)
WO1-6a	72X36	18.00						HORIZ. ARROW (SYMBOL ON PERMANENT BARRICADE)	MO4-10L	48X18	6.00							6161013		BUOYS (NO WAKE)
WO1-7	60X30	12.50						DOUBLE HEAD HORIZONTAL ARROW (SYMBOL)	MO4-10R	48X18	6.00							6161014		SPECIAL SIGN ASSEMBLY (BOATS KEEP OUT)
WO1-7a	72X36	18.00						DOUBLE HEAD HORIZ. ARROW (SYMBOL ON PERM. BARR.)	REGULATORY SIGNS									6161020		CHANNELIZER (DRUM-LIKE)
WO1-8	18X24	3.00						CHEVRON (SYMBOL)	R1-1	48X48	13.25							6161022		CHANNELIZER (CONE)
WO1-8a	30X36	7.50						CHEVRON (SYMBOL FOR DIVIDED HIGHWAYS)	R1-2	48TRI.	6.93							6161025	140	CHANNELIZER (TRIM-LINE)
WO3-1	48X48	16.00						STOP AHEAD (SYMBOL)	R1-2a	36X36	9.00							6161026		CHANNELIZER (VERTICAL PANEL)
WO3-2	48X48	16.00						YIELD AHEAD (SYMBOL)	R1-2a	36X36	9.00							6161030	16	TYPE 3 MOVEABLE BARRICADE
WO3-3	48X48	16.00						SIGNAL AHEAD (SYMBOL)	R1-3P	30X12	2.50							6161033		DIRECTION INDICATOR BARRICADE
WO3-4	48X48	16.00						BE PREPARED TO STOP	R2-1	36X48	12.00							6161040		FLASHING ARROW PANEL
WO3-5	48X48	16.00						SPEED LIMIT AHEAD	R3-1	48X48	16.00	2	32.00					6161047		TYPE 3 OBJECT MARKER
WO4-1L	48X48	16.00						MERGE (SYMBOL FROM LEFT)	R3-2	48X48	16.00	2	32.00					6161055		SEQUENTIAL FLASHING WARNING LIGHT
WO4-1R	48X48	16.00						MERGE (SYMBOL FROM RIGHT)	R3-3	36X36	9.00							6161070		TUBULAR MARKER
WO4-1aL	48X48	16.00						MERGE (LEFT)	R3-4	48X48	16.00							6161095		RADAR SPEED ADVISORY SYSTEM
WO4-1aR	48X48	16.00						MERGE (RIGHT)	R3-7L	30X30	6.25							6161096		CHANGEABLE MESSAGE SIGN, COMMISSION FURNISHED/RETAINED
WO5-1	48X48	16.00						ROAD/BRIDGE/RAMP NARROWS	R3-7R	30X30	6.25							6161096		CHANGEABLE MESSAGE SIGN, COMMISSION FURNISHED/RETAINED
WO5-3	48X48	16.00						ONE LANE BRIDGE	R4-1	36X48	12.00							6161098A	5	INTERFACE, CONTRACTOR FURNISHED/RETAINED
WO5-5	48X48	16.00						NARROW LANES	R4-2	36X48	12.00							6161099		CHANGEABLE MESSAGE SIGN WITH COMM. INTERFACE, CONTRACTOR FURNISHED/RETAINED
WO6-1	48X48	16.00						DIVIDED HIGHWAY (SYMBOL)	R4-7a	36X48	12.00							6161099		CHANGEABLE MESSAGE SIGN WITH COMM. INTERFACE, CONTRACTOR FURNISHED/RETAINED
WO6-2	48X48	16.00						DIVIDED HIGHWAY END (SYMBOL)	R4-8a	36X48	12.00							6162000A		WORK ZONE TRAFFIC SIGNAL SYSTEM
WO6-3	48X48	16.00						TWO WAY TRAFFIC (SYMBOL)	R5-1	30X30	6.25							6162002		TEMPORARY LONG-TERM RUMBLE STRIPS
WO7-3a	30X24	5.00						NEXT XX MILES (PLAQUE)	R5-1a	36X24	6.00									
WO8-1	48X48	16.00						BUMP	R6-1L	54X18	6.75							6173600D		TEMPORARY TRAFFIC BARRIER, CONTRACTOR FURNISHED/RETAINED
WO8-2	48X48	16.00						DIP	R6-1R	54X18	6.75									
WO8-3	48X48	16.00						PAVEMENT ENDS	R6-2L	24X30	5.00							6173700B		TEMP. TRAFFIC BARRIER ANCHORED, CONTRACTOR FURNISHED/RETAINED
WO8-4	48X48	16.00						SOFT SHOULDER	R6-2R	24X30	5.00									
WO8-5	48X48	16.00						SLIPPERY WHEN WET (SYMBOL)	R9-9	24X12	2.00							6173706		TEMP. TRAFFIC BARRIER STIFFNESS TRANSITION, CONTRACTOR FURNISHED/RETAINED
WO8-6	48X48	16.00						TRUCK CROSSING	R9-11L	24X18	3.00							6174000A		TEMP. TRAFFIC BARRIER HEIGHT TRANSITION, CONTRACTOR FURNISHED/RETAINED
WO8-6c	48X48	16.00						TRUCK ENTRANCE	R9-11R	24X18	3.00							6175010A		RELOCATING TEMPORARY TRAFFIC BARRIER
WO8-7	36X36	9.00						LOOSE GRAVEL	R10-6	24X36	6.00							6175011B		RELOCATING TEMP. TRAFFIC BARRIER ANCHORED
WO8-7a	36X36	9.00						FRESH OIL / LOOSE GRAVEL	R11-2	48X30	10.00	4	40.00					6175013		RELOCATING TEMP. TRAFFIC BARRIER STIFFNESS
WO8-9	48X48	16.00						LOW SHOULDER	R11-3a	60X30	12.50							6175020A		RELOCATING TEMP. TRAFFIC BARRIER HEIGHT
WO8-11	48X48	16.00	11	176.00				UNEVEN LANES	R11-4	60X30	12.50							6208064A		TEMPORARY RAISED PAVEMENT MARKER
WO8-12	48X48	16.00	9	144.00				NO CENTER LINE	CONST-3A	60X48	20.00							9029400		TEMPORARY TRAFFIC SIGNALS
WO8-15	48X48	16.00						GROOVED PAVEMENT	CONST-3X	56X12	4.67							9029401		TEMPORARY TRAFFIC SIGNALS AND LIGHTING
WO8-15P	30X24	5.00						MOTORCYCLE (PLAQUE)	MISCELLANEOUS SIGNS											
WO8-17L	48X48	16.00						SHOULDER DROP-OFF (SYMBOL LEFT)	CONST-5	48X36	12.00									
WO8-17R	48X48	16.00						SHOULDER DROP-OFF (SYMBOL RIGHT)	CONST-5	96X48	32.00									
WO10-1	42RND.	9.62						RAILROAD CROSSING	CONST-8	48X36	12.00	2	24.00							
WO12-1	24X24	4.00						DOUBLE DOWN ARROW (SYMBOL)												
WO12-2	48X48	16.00						LOW CLEARANCE (SYMBOL)												
WO12-2x	24X18	3.00						LOW CLEARANCE (PLAQUE)												
WO12-2a	84X24	14.00						OVERHEAD LOW CLEARANCE (FEET AND INCHES)												
WO12-4	120X60	50.00						LOW CLEARANCE XX FT XX IN XX MILES AHEAD												
WO12-5	120X60	50.00						WIDTH RESTRICTION XX FT XX IN XX MILES AHEAD												
WO13-1	30X30	6.25						ADVISORY SPEED (PLAQUE)												
WO16-2	30X24	5.00						XXX FEET (PLAQUE)												
WO16-3	30X24	5.00						X MILE (PLAQUE)												
WO20-1	48X48	16.00	11	176.00				ROAD/BRIDGE/RAMP WORK AHEAD												
WO20-2	48X48	16.00						DETOUR AHEAD												
WO20-3	48X48	16.00	1	16.00				ROAD CLOSED AHEAD												
WO20-4	48X48	16.00	11	176.00				ONE LANE ROAD AHEAD	616-10.05											
WO20-5	48X48	16.00						RIGHT/CENTER/LEFT LANE CLOSED AHEAD	CONSTRUCTION SIGNS											
WO20-5a	48X48	16.00						2 RIGHT/CENTER/LEFT LANES CLOSED AHEAD												
WO20-6a	48X48	16.00						RIGHT/CENTER/LEFT LANE CLOSED	616-10.10											
WO20-7a	48X48	16.00	11	176.00				FLAGGER (SYMBOL)	RELOCATED SIGNS											
WO21-2	36X36	9.00						FRESH OIL												
WO21-5	48X48	16.00						SHOULDER WORK / SHOULDER WORK AHEAD												
WO22-1	48X48	16.00						BLASTING ZONE AHEAD												
WO22-2	42X36	10.50						TURN OFF 2-WAY RADIO AND PHONE												
WO22-3	42X36	10.50						END BLASTING ZONE												
GO22-1	21X15	2.19	4	8.76				WET PAINT (AR												

